

Sanitary Rotary Lobe Positive Displacement Pumps



Fristam Pumps...
Performance You've Come To Expect

Fristam
PUMPS

Fristam's FL II Series Rotary Lobe Pump

Fristam's FL II Series Pumps use a proven design to provide gentle product handling, complete cleanability, high efficiencies, and ease of maintenance. Nine pump models and a full range of options can match process needs precisely.

Gentle On Product

The FL II's bi-wing rotors maintain your product's integrity by minimizing the potential of rotor-to-rotor contact. Its special rotor geometry reduces shear and provides gentle product handling. Additionally, the pump's simple circular motion reduces the chance of generating metal particles from rotor-to-rotor contact.

Complete Cleanability

The FL II's seal and housing are designed for thorough, easy CIP cleaning. Well-designed gasketing avoids crevices and hard-to-clean areas. Rotor-to-housing tolerances allow turbulent flow at all points in the housing during CIP. Additionally, high-temperature rotors allow for SIP.

High Efficiencies

The FL II's bi-wing rotor creates a long sealing path to minimize slip.

Easy To Maintain: Simple Timing and Seals

Rotor timing is easy: simply turn both gear keys to 12:00 and install. Radial shims are not required for timing. Rotor gaps are set outside the gearbox using a simple gapping spacer. The pump's bearings are permanently greased, while gears run in an easily viewed oil bath. The simple timing of the FL II provides for longer wear life of rotor components.

The FL II Series' seals are extremely simple. Their unique design locks both the stationary and rotary seals in place. No pins or set screws are required. The pump's components are designed to fit one way only—the right way—for easy and correct installation.

Versatile

The FL II Series offers a wide range of sizes and options to match specific process requirements. Mechanical seals are available in a combination of carbon, chrome oxide coated stainless steel, and silicon carbide. High-temperature rotors are available for extra clearance. For large particulates, the single-lobe style is available. Jacketed housings, rectangular inlets, vertical mounting and internal pressure relief options address special requirements. All standard drives may be used.

Additional Benefits:

- **Run Dry Capabilities:** No rotor-to-rotor contact gives the FL II run dry capabilities, with a wetted seal.
- **Compact Design:** Small footprint saves space.
- **Extra Corrosion Resistant:** Housing, rotors and seal components are low-ferrite 316L.
- **Handles High Process Temperatures:** Standard rotors handle process temperatures to 180° F. High temperature rotors can be used in processes up to 360° F. Standard pumps can be steamed in place at 230° F with static rotors.
- **Self-Draining:** Simple vertical mounting makes the pump entirely self-draining.
- **Unique Leak Detection:** To provide an extra margin of safety, the FL II is designed to leak externally should an internal o-ring fail.
- **Flexible Installation:** The gearbox of models 15-100 allows for top, bottom or side mount. This, along with the bi-directional rotation, gives complete installation flexibility.

Protect Your Valuable Product

Clean

- 316L low-ferrite content stainless steel—housing, rotors, and seal components
- CIP-able and SIP-able

Gentle

- Bi-wing design eliminates rotor-to-rotor contact
- Large displacement cavities pump delicate products gently

Efficient

- Long seal path minimizes slip for maximum efficiency

Simple

- Timing is simple: turn both gear keys to 12:00 and assemble
- Simple, straight-cut gears

Compact

- Small footprint

FL II Specifications

FL II Model	15	58S	58L	75S	75L	100S	100L	130S	130L
Gallons Per Revolution	0.0056	0.0267	0.039	0.072	0.098	0.176	0.274	0.465	0.645
Maximum Pressure	130 psi	130 psi	115 psi	170 psi	120 psi	170 psi	120 psi	170 psi	120 psi
Fitting Size	0.75"	1"	1.5"	1.5"	2"	2.5"	3"	3"	4"

Components at a Glance

(Models 75-130 only)

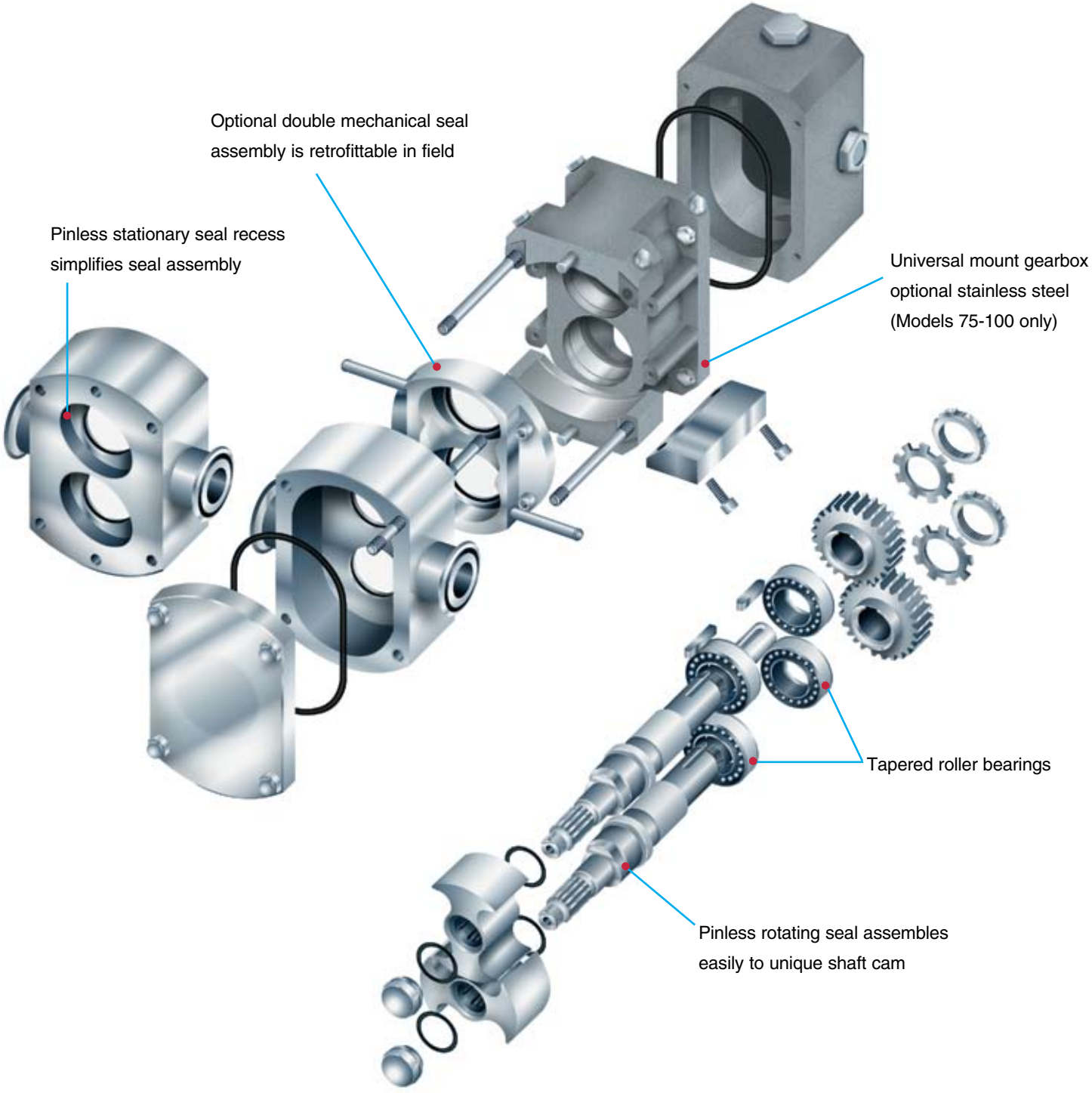

Optional double mechanical seal assembly is retrofittable in field

Pinless stationary seal recess simplifies seal assembly

Universal mount gearbox optional stainless steel (Models 75-100 only)

Tapered roller bearings

Pinless rotating seal assembles easily to unique shaft cam

Select the Right Pump for Your Process

General Specifications

- Housing, cover, shaft and rotors—316L stainless steel
- Elastomers—viton standard
- Seals—single mechanical; Carbon vs. Chrome Oxide coated Stainless Steel standard double mechanical; Carbon vs. Chrome Oxide coated Stainless Steel vs. Carbon standard
- Gearbox; painted mild steel
- Universal mounting is standard (except model 130)

Special Packages

- CIP/SIP package
- Rectangular inlet
- Lower Ra finishes on internal product areas
- Electropolish

Options

- Wide variety of drive bases and selections
- Seals—single or double mechanical
- Mechanical seal material—Silicon Carbide
- Elastomer materials—Viton®, EPDM, Kalrez, Chemraz®, Teflon, Silicone
- Integral pressure relief valve
- Optional handwheel for pressure relief valve override
- Vertical mount
- High temperature rotors
- Jacketed housing
- Jacketed cover
- Single lobe
- Most sanitary and industrial port connections

Ordering Matrix

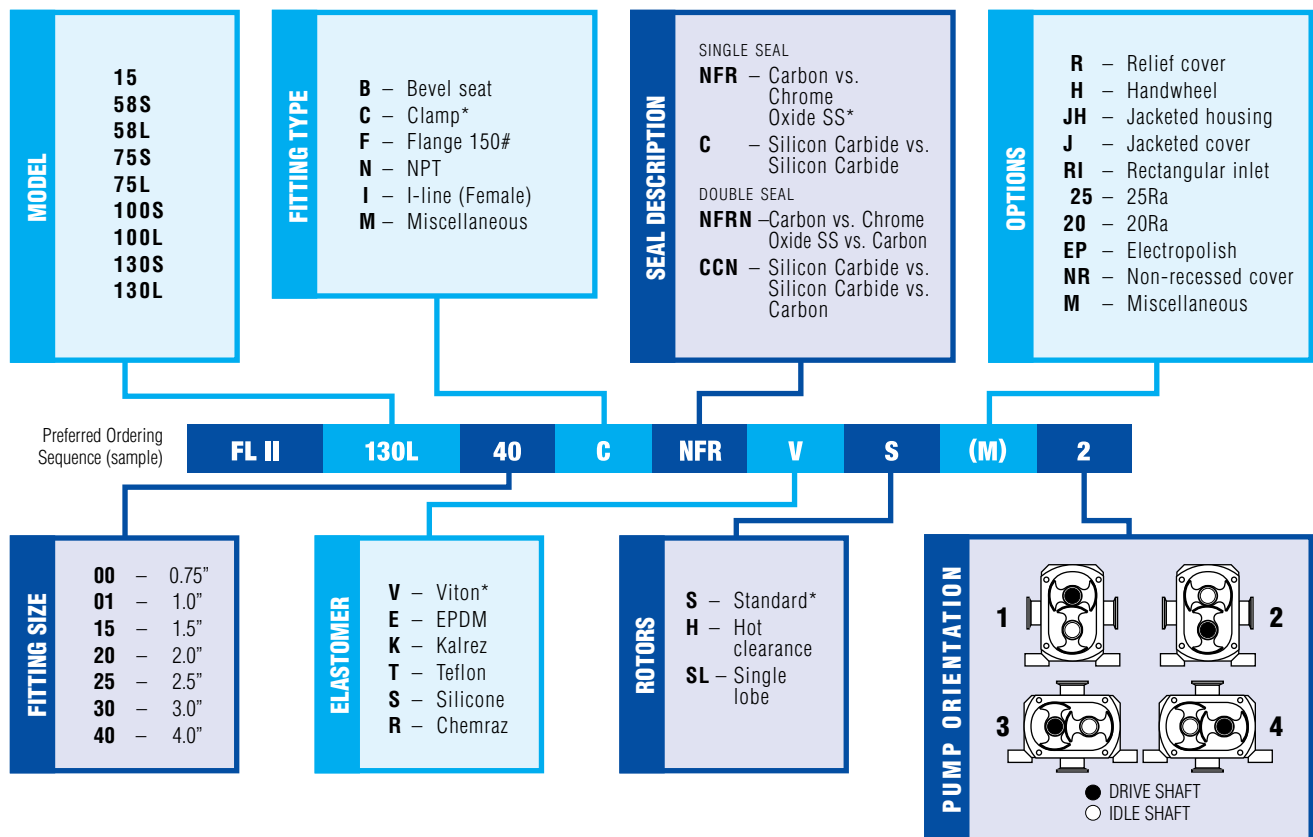

* = Standard

Composite Curves

FL II 15-75 Performance Composite Curves

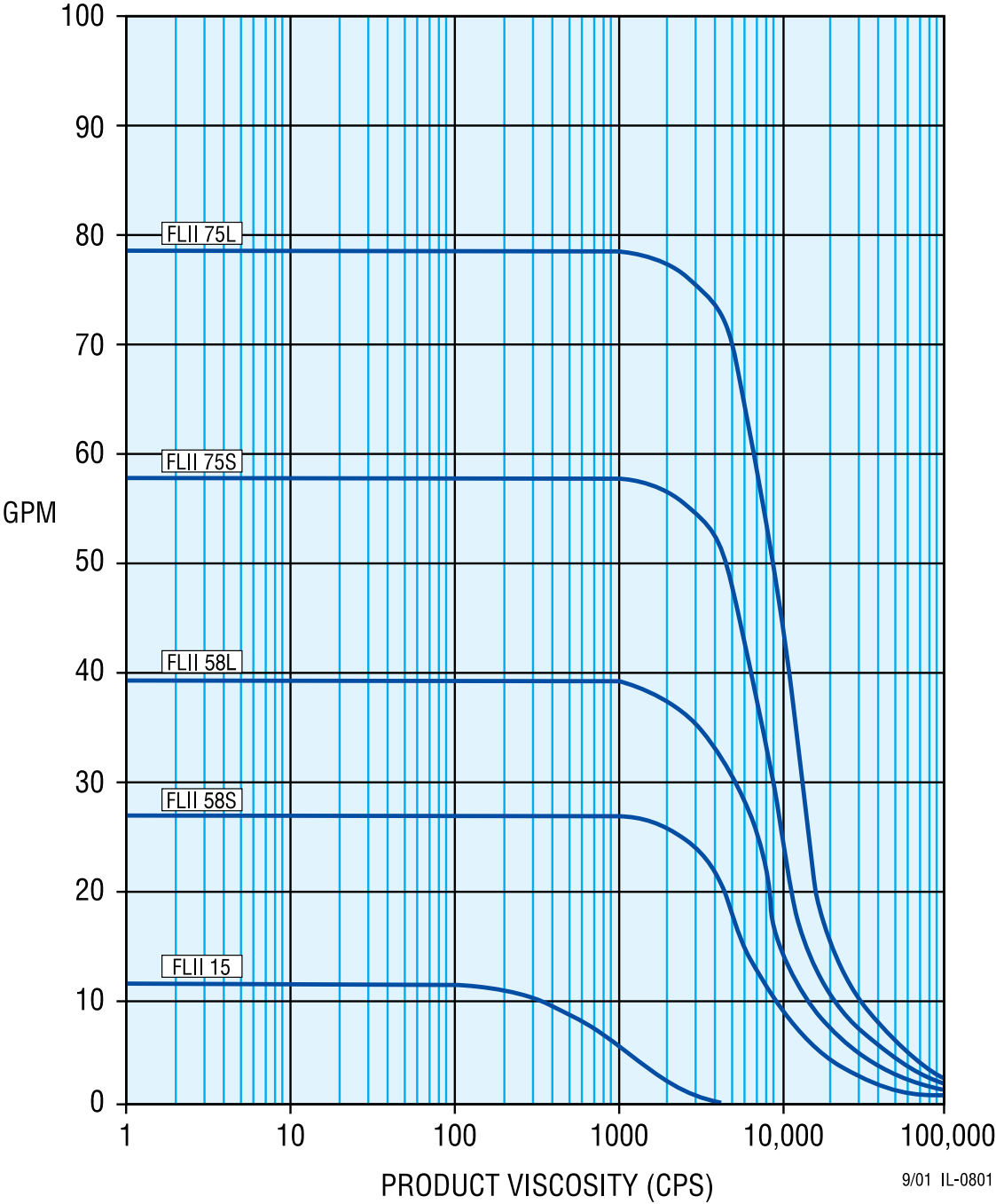

See Fristam's FL II curve packet for individual pump performance curves.

Composite Curves

FL II 100-130 Performance Composite Curves

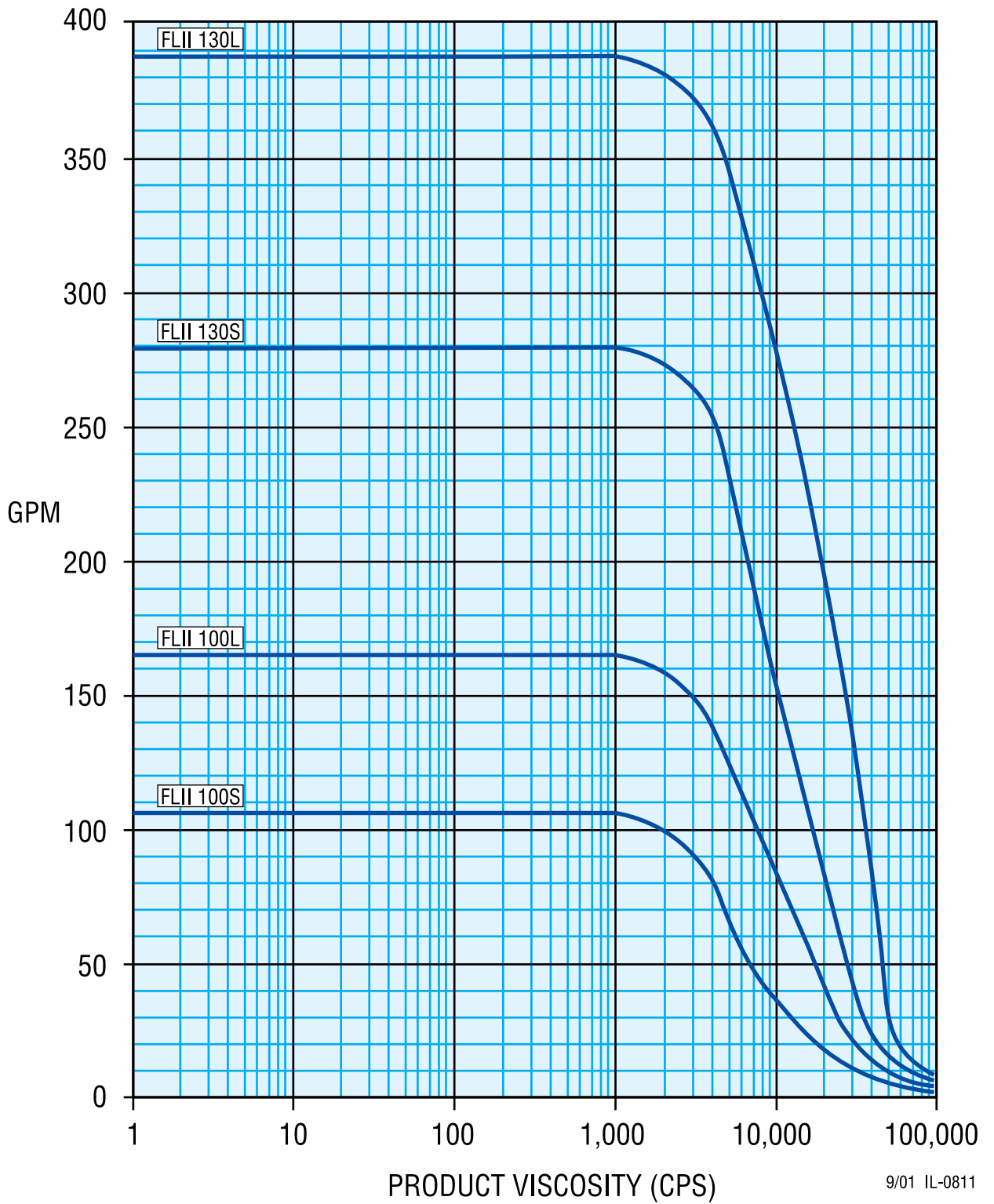

Worldwide Contact Details

North America/ South America

Fristam Pumps USA
P.O. Box 620065
2410 Parview Road
Middleton, WI 53562-2524

TEL: 1-608-831-5001
1-800-841-5001
FAX: 1-608-831-8467

www.fristam.com
fristam@fristampumps.com



Belgium/Luxembourg

Fristam N.V.
Aartselaar

France

Pompes Fristam S.A.
Noisy-le-Sec

Germany

Fristam Pumpen F. StampKG
(GmbH & Co)
Hamburg

Great Britain

Fristam Pumps (UK) Ltd.
Hailsham

India

Fristam Pumps (I) Pvt. Ltd.
Pune

Italy

Fristam Italia S.r.l.
Borgo Ticino (NO)

Japan

Stamp Pumps of Japan Ltd.
Tokyo

Netherlands

Fristam B.V.
De Meern

New Zealand

Fristam Pumps Ltd.
Cambridge

Peoples Republic of China

Fristam Pumps (Shanghai) Co. Ltd.
Shanghai

Poland

Fristam Polska sp.z.o.o.
Warsaw

Russian Federation

Fristam Pumpen R.A.
Moscow

Scandinavia

Fristam Pumper A/S
Saeby

S.E. Asia

Fristam Pumpen A.R.
Singapore

Spain/Portugal

Fristam Iberica S.L.
Barcelona

Fristam's Commitment

Fristam Pumps manufactures the sturdiest products in the industry. Our design reduces repair/replacement cost, downtime and energy consumption, and therefore yields high lifetime value. Fristam is one of the most accessible equipment companies in the world. Fristam's dedication and quality service do not end with your initial purchase. An international network of manufacturing facilities, sales offices and distribution supports Fristam's commitment to customer satisfaction.

3-A, GMP, U.S.D.A., F.D.A., ISO and EHEDG

Fristam complies with and supports regulatory standards. FL II Series pumps meet all applicable industry standards for performance, cleanliness and design. As a registered ISO 9001:2000 company, Fristam is committed to consistent quality products.

