

**EXTRUSION PROFILES  
CORD STOCK & SHEET MATERIAL**



**NEWMAN**<sup>TM</sup>  
SANITARY GASKET COMPANY

PRODUCTS OF INTEGRITY...FROM PEOPLE OF INTEGRITY

# EXTRUSIONS

Newman's extrusion capabilities are available in straight lengths or in bonded shapes to form an endless component. Newman can extrude a custom profile (limited to 1" in diameter) from 2 feet to 50 foot\*\* lengths from our Buna-N, Viton®, and EPDM compounds.

Custom extrusions can be made to your specifications in compounds that meet FDA requirements. Our specially formulated compounds make Newman your number one source for these superior FDA compliant components. We currently have several standard extrusion molds available for your use. The columns on the right show some of the profiles and dimensions of the extrusion molds that are in stock.

## FDA Buna-N Manhole Gaskets

Universal Gaskets will fit all standard size 16" x 20" doors, with the exception of Pfaudler. When ordering a non-standard gasket, the circumference of the door is required in order to provide correct size and fit.

• Available in non-standard lengths by the foot for your fabrication.

#964-222  
SPE-4900-01  
Black Buna-N

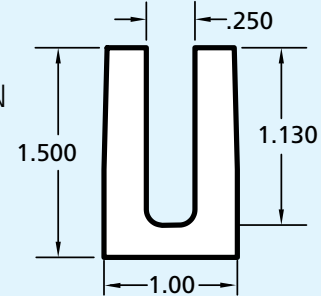

#932-398  
SPE-4900-02A  
White Buna-N

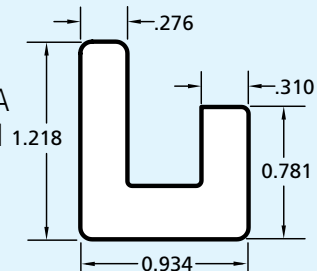

SPE-4900-111  
Black EPDM

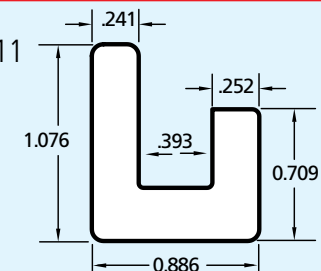

#41186-B  
SPE-4900-23  
White Buna-N

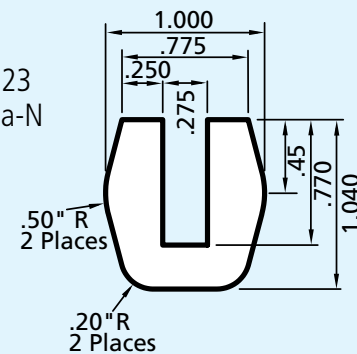

#402-6229  
SPE-4900-44  
White Buna-N

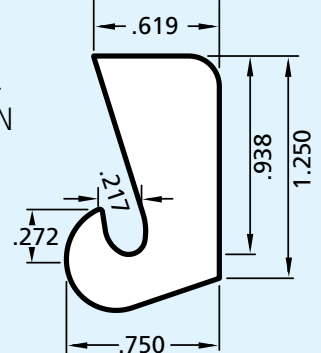

SPE-4900-142  
White Silicone

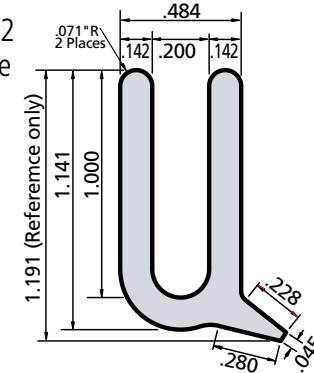

SPE-4900-78  
Black Buna-N

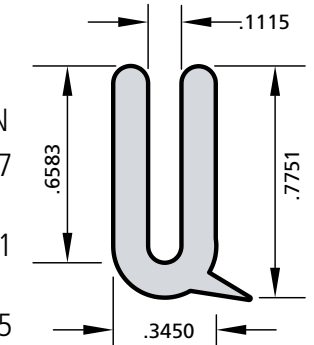

SPE-4900-88  
White Buna-N

SPE-4900-117  
Black EPDM

SPE-4900-121  
White EPDM

SPE-4900-125  
Black Viton®

SPE-4900-157  
White Viton®

SPE-4900-137  
Red Silicone

SPE-4900-144  
Black EPDM

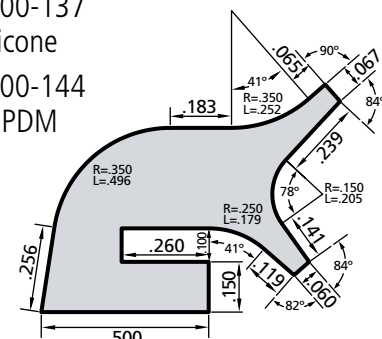

SPE-4900-109  
White Buna-N

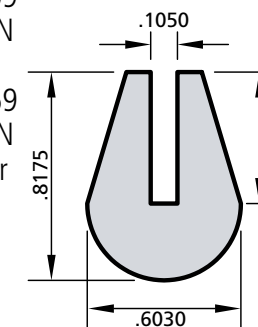

SPE-4900-159  
White Buna-N  
50 durometer

SPE-4900-133  
Red Silicone

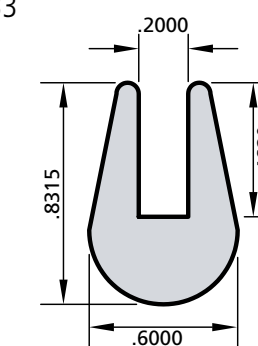

SPE-4900-147  
Black EPDM

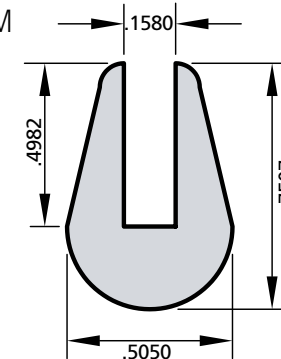

SPE-4900-80  
White Buna-N  
50 durometer

SPE-4900-146  
White Buna-N  
70 durometer

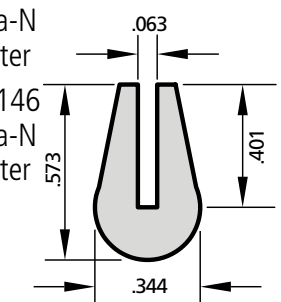

SPE-4900-62  
White Buna-N  
70 durometer

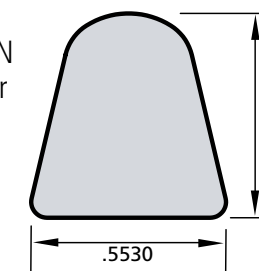

SPE-4900-79  
White Buna-N  
50 durometer

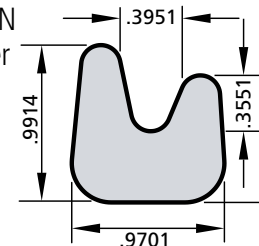

SPE-4900-05  
Black Buna-N  
50 durometer

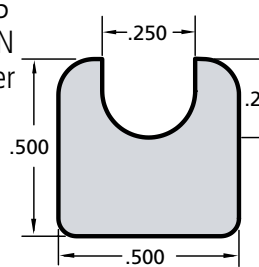

SPE-4900-107  
White Buna-N  
50 durometer

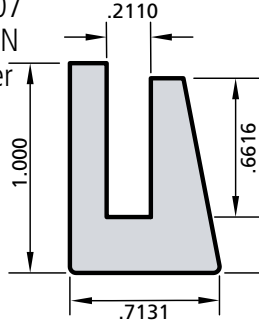

SPE-4900-134  
Black EPDM  
70 durometer

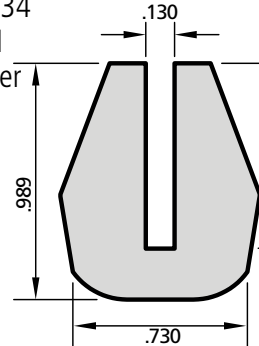

[www.newmangasket.com](http://www.newmangasket.com)



Viton® is a registered trademark of DuPont Performance Elastomers.

\*\* 5 feet - 20 feet lengths is customary; limited profiles available in 50 foot rolls.

Newman Sanitary Gasket has available a wide range of cord stock in various materials and thickness. Listed below are the materials and the dimensions of the cross sections that are currently available. These cord stocks can be purchased by the foot or custom made into O-Rings. Call for pricing and availability.

<b>CORD STOCK (round)</b>														
Buna-N Black	.063	.070	.093	.103	.125	.139	.156	.187	.218	.250	.275	.281	.312	.343
	.375	.406	.437	.468	.500	.562	.625	.750	.875	1.000	1.500			
Buna-N White	.063	.093	.125	.139	.156	.187	.218	.250	.275	.281	.312	.343	.375	.406
	.437	.468	.500	.562	.625	.750	.875	1.000						
EPDM Black	.063	.093	.125	.139	.156	.187	.210	.218	.236	.250	.275	.281	.295	.312
	.343	.375	.406	.437	.468	.500	.562	.625	.750	.875	1.000			
EPDM White	.139	.187	.250	.312	.500	.562	1.000							
Silicone White	.125	.250	.275	.312	.375	.500	.625	.750						
Silicone Red	.103	.250	.275	.312	.375									
Viton® Black	.063	.093	.125	.139	.156	.187	.210	.218	.250	.275	.281	.312	.343	.375
	.406	.437	.468	.500	.562	.625	.750							
Viton® White	.125	.156	.187	.218	.275	.281	.312	.343	.375	.406	.437	.468	.500	.562
	.625	.750												

<b>CORD STOCK (square)</b>							
Buna-N White	.250	.313	.330	.375	.500	.625	.750
Buna-N Black				.375	.500	.625	1.000
EPDM White	.250						
EPDM Black	.250			.500	.625		

<b>CORD STOCK (rectangle)</b>				
Buna-N White	.500 x .375	.500 x .625	.625 x .375	.875 x .375
Buna-N Black	.500 x .625	.500 x .750	.625 x 1.000	
EPDM Black	.500 x .375			
Silicone Red	.750 x .250			
Viton® Black	.500 x .250			

### **SHEET MATERIAL**

Newman Sanitary Gasket Company is currently making available our high quality sheet material made from our own specially formulated compounds. Sheet material is available in various thickness and in 36" standard width. Material can be ordered by the linear inch and is most suitable for die cutting.



Buna-N Black	.063	.125	.187				
Buna-N White	.031	.063	.094	.125	.187	.250	.375
EPDM Black	.031	.063	.125	.187	.250		
EPDM White	.063	.125	.250				
Silicone Red	.031	.063	.125	.187			
Silicone White		.125					
Viton® Black	.063	.125					
Viton® White	.063	.094	.125	.187	.250		



P.O. Box 222, Lebanon, OH 45036 • Phone: 513-932-7379 • Fax: 513-932-4493  
[www.newmangasket.com](http://www.newmangasket.com) • E-mail: [customer@newmangasket.com](mailto:customer@newmangasket.com)