

# PG-EG Sanitary Gas Filter Housing

*Stainless steel gas filter housing for sanitary applications*

## Product Description

Designed for purification of compressed air and technical gases in the pharmaceutical, biotechnology, chemical, electronic, food and beverage industries. PG-EG housings are equipped with sanitary Tri-clamp and flange connections, and have an electropolished surface finish of Ra 30. The top vent is sealed with a pharma plug while the bottom condensate drain is equipped with a pharma valve. PG-EG housings are designed to yield low differential pressures at high flow rates.

Available in 14 different sizes with capacity ranging from 4.5 to 1,620 scfm at 14.7 psia. Optional connections are also available to adapt the filter to your specific requirements. Standard housings utilize Donaldson filter elements with 2-inch, double o-ring, plug-in connections. A broad selection of filter elements is available to meet the compatibility and micron rating requirements of your process.



**PG-EG Sanitary Gas Filter Housing** for compressed air and other gases in sanitary quality

### Materials

Filter housings	304 or 316L stainless steel
Clamp	304 stainless steel
Pharma plug	304 stainless steel
Pharma valve	304 stainless steel
Housing gasket	EPDM (other gaskets on request)

### Surface finish

0006-1920	Etched, passivated, and electropolished Ra 30
-----------	---

### Maximum operating pressure

0060-0192	150 psig (250 psig on request)
0432-1920	150 psig

### Maximum operating temperature

Depends on the gasket of the housing, up to 390°F

### Connection types

Clamp (standard at 0006-0192)
ANSI or DIN flange (standard starting at 0432; optional up to 0192)
Weld ends
Other connections and bigger housings are available on request

**PG-EG 0006-0192**  
with Tri-clamp connection

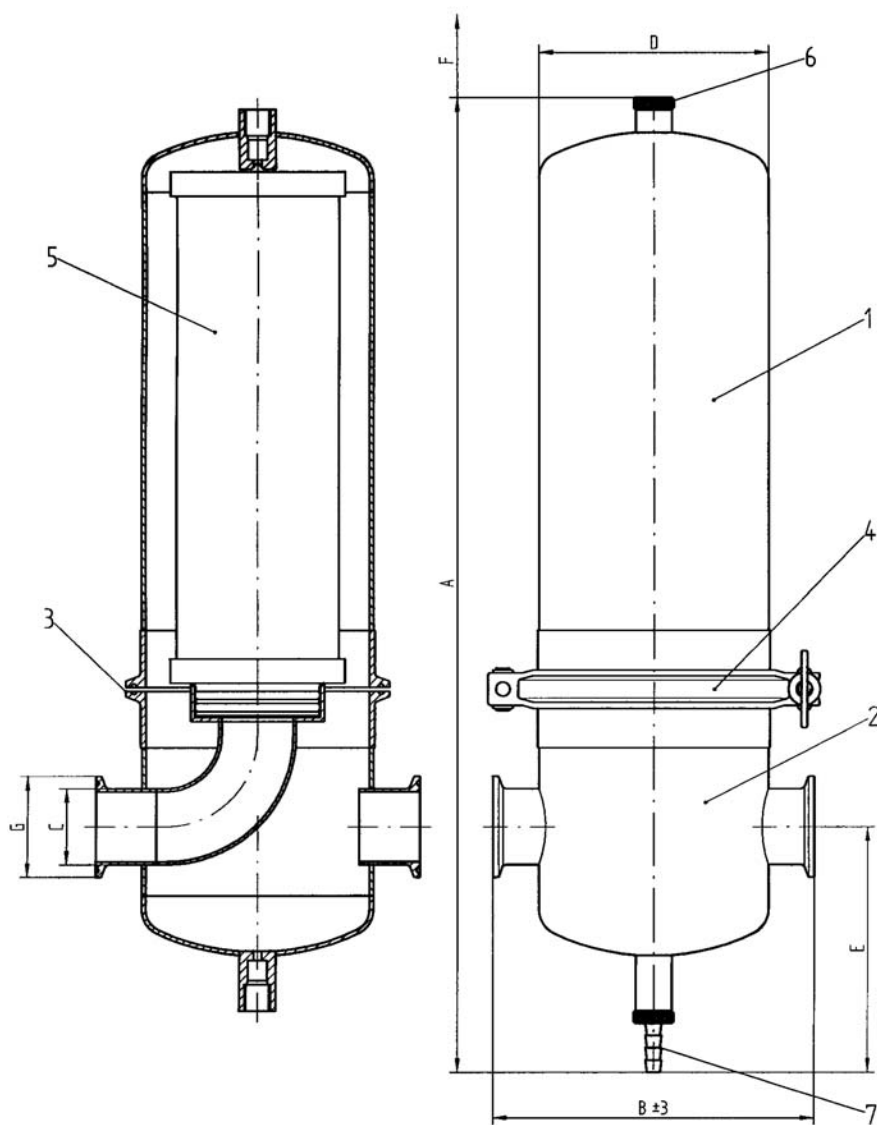

Pos.	Description
1	upper housing bowl
2	lower housing bowl
3	housing gasket
4	clamp fastener
5	filter element
6	pharma plug
7	pharma valve

Max. operating pressure:	150 psig
Test pressure:	225 psig
Design temperature:	390°F
Operating temperature:	-20 / +300°F
<b>Material</b>	
Housing: 304 or 316L stainless steel	
Attachment parts: 304 stainless steel	

Dimensions										
Type	Volume (gal)	Weight* (lb)	A (inches)	B (inches)	C (inches)	ØD (inches)	E (inches)	F (inches)	ØG (inches)	Element
0006	0.1	3	10	4.72	0.50	3.0	3	4	1.34	03/10
0018	0.2	3	12	4.72	0.75	3.0	3	6	1.34	05/20
0032	0.6	6	13	6.30	1.00	4.5	4	6	1.99	05/30
0048	0.7	7	16	6.30	1.50	4.5	4	8	1.99	07/30
0072	0.9	8	19	6.30	2.00	4.5	4	11	2.52	10/30
0108	1.2	9	25	6.30	2.50	4.5	4	18	3.05	15/30
0144	2.2	15	33	7.28	3.00	5.0	5	23	3.58	20/30
0192	3.0	19	43	7.28	3.00	5.0	5	33	4.17	30/30

\*Without filter element

**PG-EG 0006-0192**  
with ANSI flange connection 150 lb

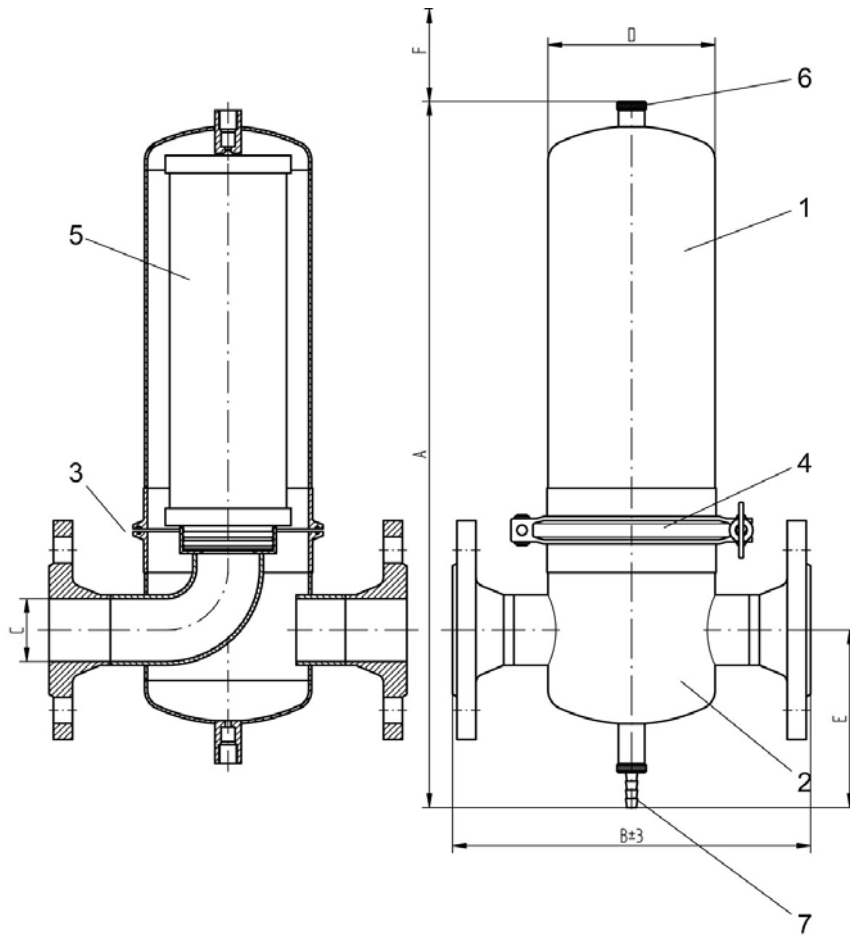

Pos.	Description
1	upper housing bowl
2	lower housing bowl
3	housing gasket
4	clamp fastener
5	filter element
6	pharma plug
7	pharma valve

Max. operating pressure:	150 psig
Test pressure:	225 psig
Design temperature:	390°F
Operating temperature:	-20 / +300°F
<b>Material</b>	
Housing: 304 or 316L stainless steel	
Attachment parts: 304 stainless steel	

Dimensions									
Type	Volume (gal)	Weight* (lb)	A (inches)	B (inches)	C** (inches)	ØD (inches)	E (inches)	F (inches)	Element
0006	0.1	5	10	7.48	0.50	3.0	3	4	03/10
0018	0.2	8	12	7.48	0.50	3.0	3	6	05/20
0032	0.6	11	13	9.25	1.00	4.5	4	6	05/30
0048	0.7	12	16	9.45	1.25	4.5	4	8	07/30
0072	0.9	16	19	9.45	1.50	4.5	4	11	10/30
0108	1.2	20	25	9.84	2.00	4.5	4	18	15/30
0144	2.2	34	33	10.83	2.25	5.0	5	23	20/30
0192	3.0	41	43	11.22	3.00	5.0	5	33	30/30

\*Without filter element

\*\* 150 lb, ANSI B 16.5

**PG-EG 0432-1920**

with ANSI flange connection 150 lb

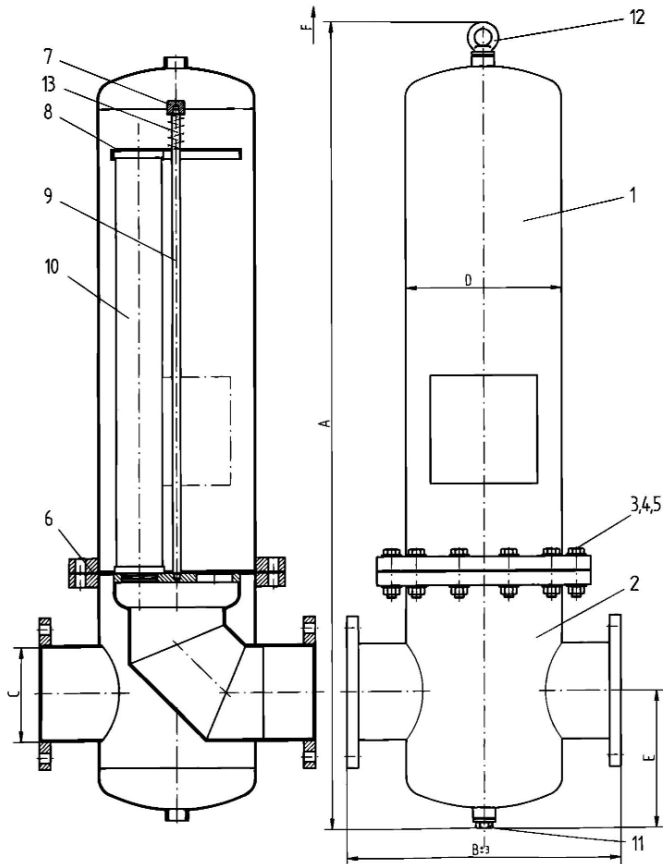

Pos.	Description
1	upper housing bowl
2	lower housing bowl
3	housing gasket
4	clamp fastener
5	filter element
6	pharma plug
7	pharma valve
8	bracket bolt
9	anchor bolt
10	filter element
11	plug
12	lifting eye nut
13	spring

Max. operating pressure:	150 psig
Test pressure:	225 psig
Design temperature:	390°F
Operating temperature:	-20 / +300°F
<b>Material</b>	
Housing:	304 or 316L stainless steel
Attachment parts:	304 stainless steel

Dimensions									
Type	Volume (gal)	Weight* (lb)	A (inches)	B (inches)	C** (inches)	ØD (inches)	E (inches)	F (inches)	Element
0432	9.5	95	37.5	16.14	4	8.6	7.7	23	3x20/30
0576	11.9	97	47.8	16.14	4	8.6	7.7	33	3x30/30
0768	20.3	154	52.1	18.90	6	10.8	8.6	33	4x30/30
1152	29.1	176	55.7	21.26	6	12.8	9.3	33	6x30/30
1536	50.2	298	59.5	25.98	8	16.0	12.8	33	8x30/30
1920	50.2	298	59.7	25.98	8	16.0	12.8	33	10x30/30

\*Without filter element

\*\* 150 lb, ANSI B 16.5