

## Ultrapure® R-EG/R-TF

*The increasing density of surface features on semiconductor circuits requires ever higher levels of purity in gases and other materials used throughout the manufacturing process. Donaldson's Ultrapure R-EG/R-TF filter system meets those demands.*

Ultrapure R-EG filter housings use the R-TF depth filter cartridge to purify oxygen, argon, helium, nitrogen and other gases down to a particle size of 0.01 µm.

The R-EG/R-TF filter system is an ideal point-of-use filter for the electronics industry to help assure trouble-free production with consistent quality.

### Product Description

Constructed of 316L stainless steel, this unit has an inner and outer surface finish of Ra 20. The R-TF filter element utilizes Donaldson's Ultradepth borosilicate filter media for high dirt-holding capacity and low pressure drop.

### Applications Requiring High Purity Gases

- Photoresist manufacture
- Ion doping
- Oxidation/diffusion ovens
- Wafer drying
- Gas supply for automatic control systems



The Ultrapure® gas filter R-EG housing with R-TF depthfilter

Ultrapore Features	Benefits
Absolute retention	The Donaldson Ultrapore® R-EG/R-TF gas filter systems was developed especially for the semiconductor industry, and retains particles down to a size of 0.01 µm.
Long service life / low operating costs	The high dirt holding capacity of the R-TF filter element allows for long service life and low differential pressure, leading to low operating costs.
Safety from leakage	The upper and lower housing sections are secured with a v-clamp and Viton®* gasket, assuring a positive seal against leakage.
No particle emission	No fibers or other particles migrate from the patented Donaldson Ultrafilter depth filter media used in the R-TF element.
	*Viton is a registered trademark of E.I. du Pont de Nemours and Company

#### Materials

Filter housing:	316L stainless steel
Housing seal:	Viton® (Bam-passed)
Inner core:	316L stainless steel
Outer core:	316L stainless steel
End caps:	316L stainless steel
Filter media:	Ultradept® (Borosilicate fiber)
Element o-rings:	EPDM or Viton®

#### Absolute retention rates

0.01 µm

#### Maximum operating pressure

300 psig

#### Maximum operating temperature

250°F

#### Surface

Electropolished to Ra 20

#### Types of connections

VCR ¼" female/female (std);  
Welding ends and VCR ¼" male/male on request

### R-TF Pressure Drop at 44 psig — Air

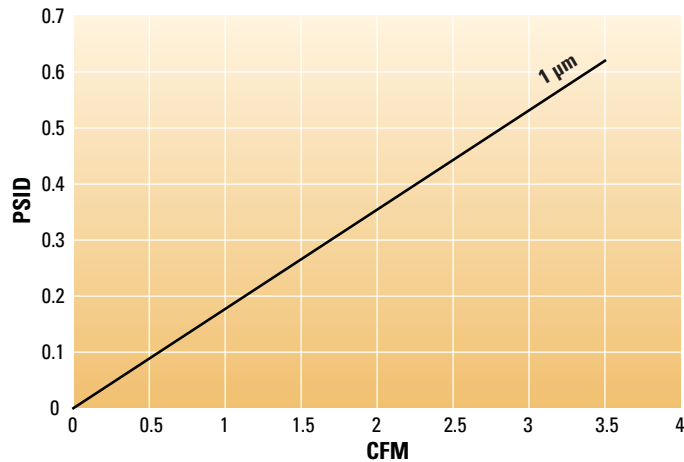

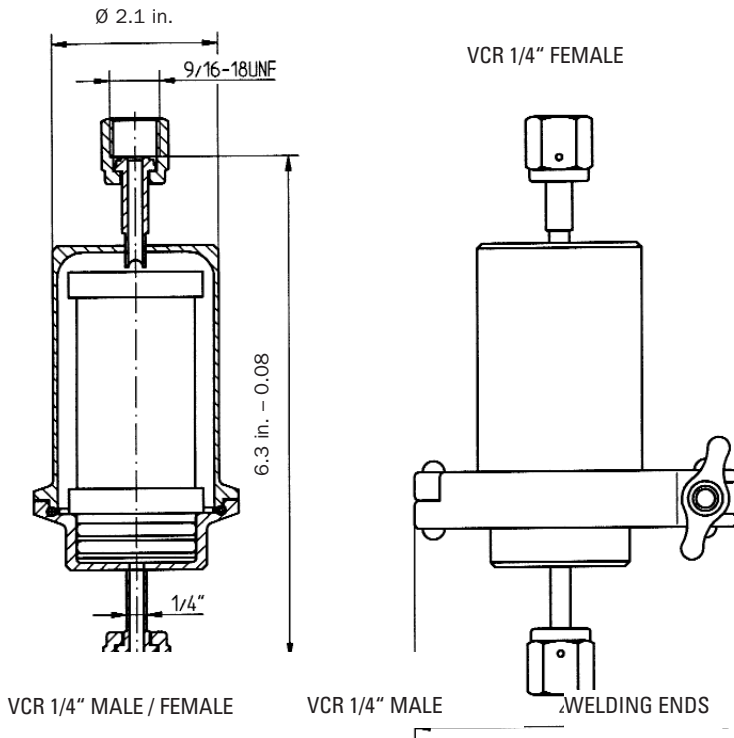

Max. operating overpressure:	300 psig
Test pressure:	450 psig
Max. operating temperature:	250°F
Medium:	Inert gases
Method of welding:	TIG
Material:	housing: 316L clamp: 304 o-ring: Viton® (Bam-passed)
Finish:	electropolished to Ra 20

VCR 1/4" MALE / FEMALE

VCR 1/4" MALE

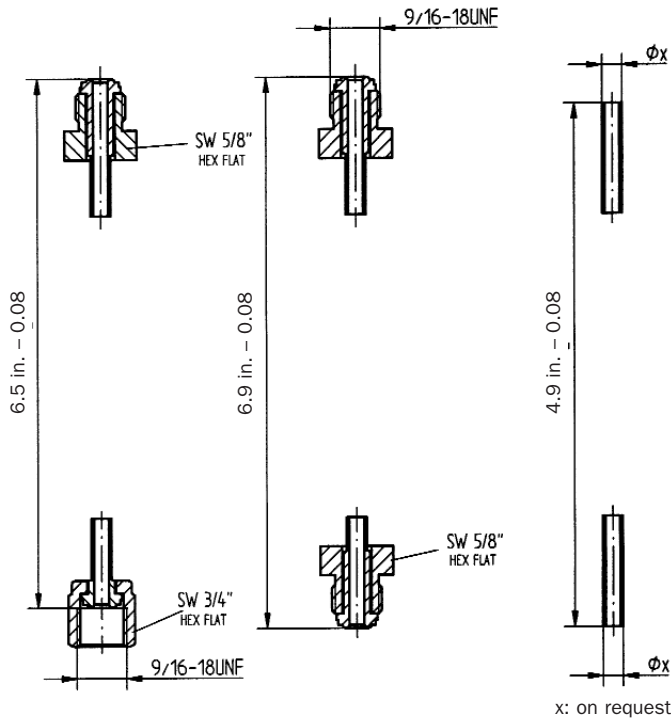



### Ultrapure® R-EG/R-TF

Ultrapure R-EG filter housings use the R-TF depth filter cartridge to purify oxygen, argon, helium, nitrogen and other gases down to a particle size of 0.01  $\mu\text{m}$

*when*  
**PURITY COUNTS...**



**Donaldson**  
Filtration Solutions

Donaldson Company, Inc.  
Process Filtration  
P.O. Box 1299  
Minneapolis, MN  
55440-1299 U.S.A.

Tel 800.543.3634 (USA)  
Tel 800.343.3639 (within Mexico)  
processfilters@mail.donaldson.com  
www.donaldson.com

Information in this document  
is subject to change without notice.

© 2007 Donaldson Company, Inc.  
Printed in U.S.A. on recycled paper

Bulletin No. PRO-218