



Bevel Seat Fittings



Stainless Steel Flow Control Equipment for the
Food, Beverage, Dairy, Cosmetics, Biotechnology,
Pharmaceutical and Electronics Processing Industries

Bevel Seat Fittings



Top Line precision crafted Bevel Seat ACME Thread Union Fittings provide fast, sanitary and secure connections. Polished fittings meet or exceed FDA and 3A regulatory standards.

Bevel Seat Specifications

- Size Range: 1" OD through 4" OD
- Materials: 304 (Stock No. Prefix 34)
316L (Stock No. Prefix 36)
- Finish: No. 7 – ID and OD (standard)
No. 5 – OD only (special)
No. 3 – ID only (special)
No. 1 – unpolished (special)

Ordering Specifications

- Specify:
 - Quantity
 - Size
 - Product Description
 - Stock Number
 - Material Type
 - Polish Requirements

Cataloged part numbers are for Type 304 Stainless Steel

Example

Quantity	Size	Product Description	Stock Number	Material Type	Polish
↓	↓	↓	↓	↓	↓
<u>3 Each</u>	<u>2"</u>	<u>2C-90°</u>	<u>#343520C</u>	<u>Type 304</u>	<u>No. 7</u>
<u>3 Each</u>	<u>2"</u>	<u>2C-90°</u>	<u>#363520C</u>	<u>Type 316L</u>	<u>No. 7</u>

13H-HEX UNION NUT (3A)

SIZE (TUBE O.D.)	A	B	STOCK NO.
1	29/32	1-13/16	346510
1-1/2	31/32	2 -13/32	346515
2	1-1/16	3	346520
2-1/2	1-3/16	3-19/32	346525
3	1-9/32	4 -3/16	346530
4	1-1/2	5-7/16	346540

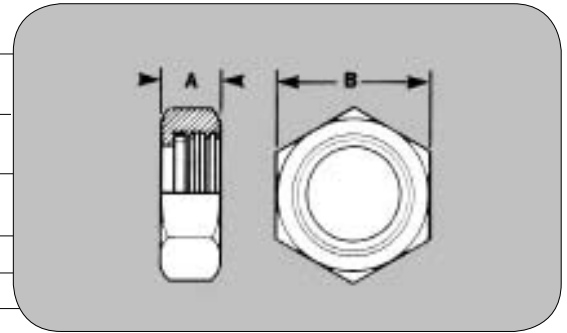

2C-90° SWEEP ELL (3A)

SIZE (TUBE O.D.)	A	STOCK NO.
1	2-3/16	343510C
1-1/2	2-31/32	343515C
2	3-23/32	343520C
2-1/2	4-27/32	343525C
3	5-29/32	343530C
4	8-1/16	343540C

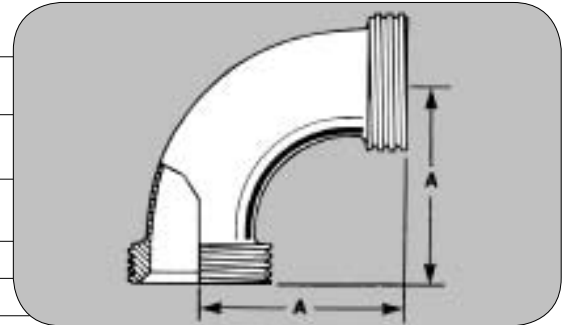

2F-90° SWEEP ELL (3A)

SIZE (TUBE O.D.)	A	STOCK NO.
1	2-3/16	343510F
1-1/2	2-31/32	343515F
2	3-23/32	343520F
2-1/2	4-27/32	343525F
3	5-29/32	343530F
4	8-1/16	343540F

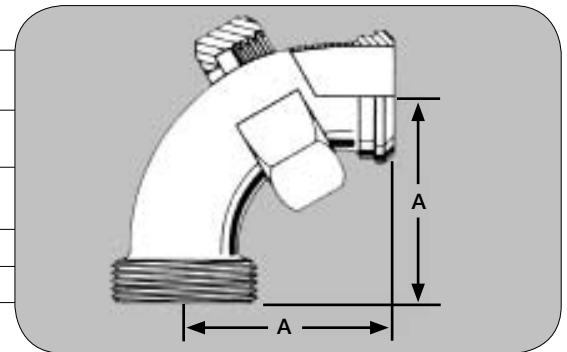

HEX NUT INCLUDED

2E-90° SWEEP ELL (3A)

SIZE (TUBE O.D.)	A	STOCK NO.
1	2-3/16	343510E
1-1/2	2-31/32	343515E
2	3-23/32	343520E
2-1/2	4-27/32	343525E
3	5-29/32	343530E
4	8-1/16	343540E

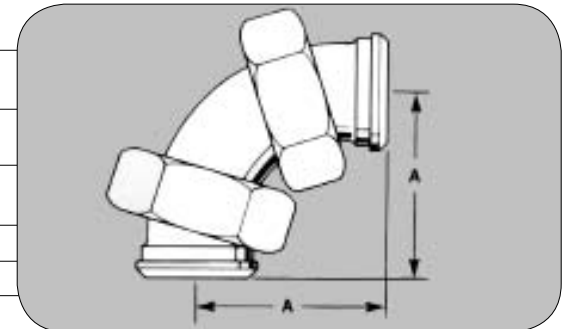

HEX NUTS INCLUDED

2F-31-90° CONCENTRIC REDUCING ELL (3A)

SIZE (TUBE O.D.)	A	B	STOCK NO.
1-1/2 X 1	2-3/16	1-15/16	343615
2 X 1	2-3/16	2-1/16	343620
2 X 1-1/2	2-31/32	2-13/16	343620A
2-1/2 X 1-1/2	2-31/32	2-13/16	343625
2-1/2 X 2	3-23/32	3-9/16	343625A
3 X 1-1/2	2-31/32	2-15/16	343630
3 X 2	3-23/32	3-11/16	343630A
3 X 2-1/2	4-27/32	4-7/16	343630B
4 X 2-1/2	4-27/32	4-9/16	343640
4 X 3	5-29/32	5-5/16	343640A

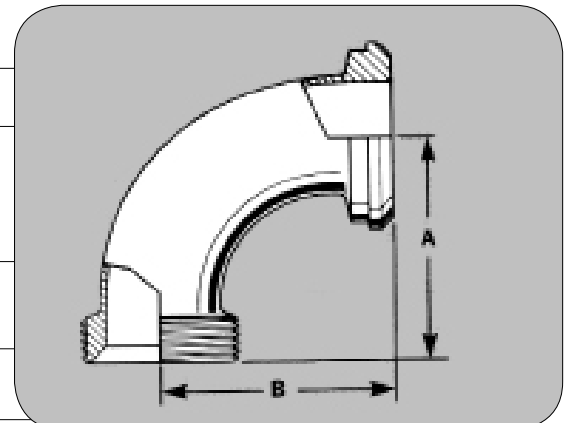

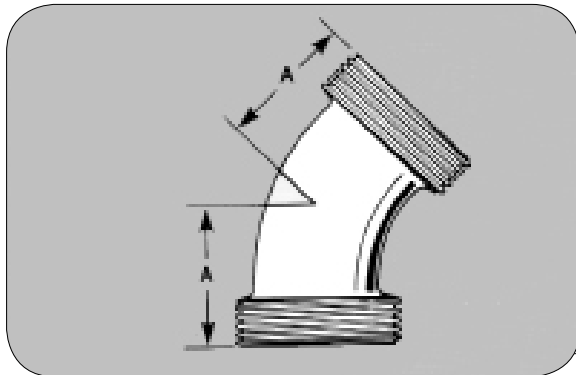

2K-45° SWEEP ELL (3A)

SIZE (TUBE O.D.)	A	STOCK NO.
1	1-5/16	343810
1-1/2	1-21/32	343815
2	2-1/8	343820
2-1/2	2-5/8	343825
3	3-1/8	343830
4	4-1/4	343840

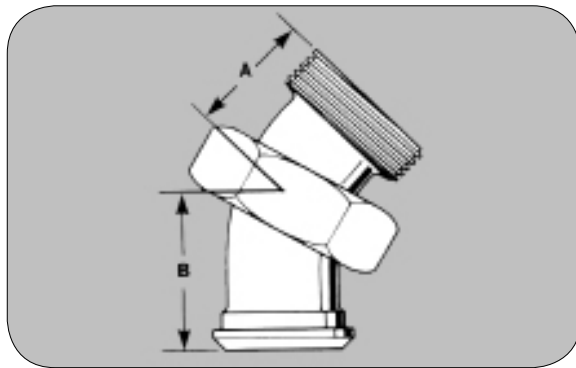

2P-45° SWEEP ELL (3A)

SIZE (TUBE O.D.)	A	B	STOCK NO.
1	1-5/16	2 -1/8	343910
1-1/2	1-21/32	2 -1/8	343915
2	2-1/8	2 -5/16	343920
2-1/2	2-5/8	2 -9/16	343925
3	3-1/8	2 -29/32	343930
4	4-1/4	3 -7/8	343940

HEX NUT INCLUDED

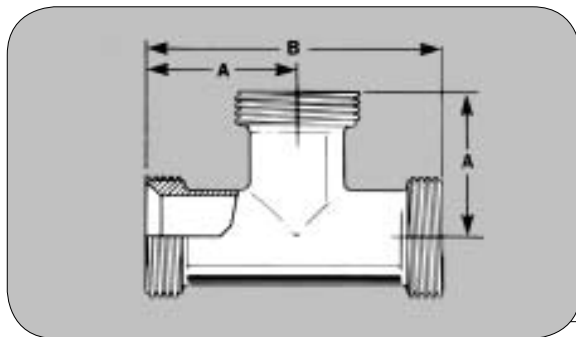

7 TEE (3A)

SIZE (TUBE O.D.)	A	B	STOCK NO.
1	1-13/16	3-5/8	344010
1-1/2	2-3/8	4-3/4	344015
2	2-25/32	5-9/16	344020
2-1/2	3-3/16	6-3/8	344025
3	3-1/2	7	344030
4	4-21/32	9-5/16	344040

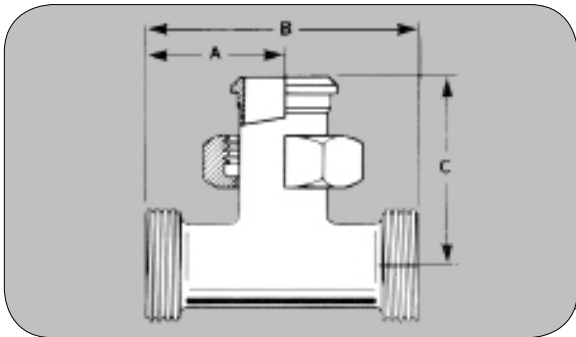

7A TEE (3A)

SIZE (TUBE O.D.)	A	B	C	STOCK NO.
1	1-13/16	3-5/8	2-11/16	344010A
1-1/2	2-3/8	4-3/4	3-13/32	344015A
2	2-25/32	5-9/16	3-13/16	344020A
2-1/2	3-3/16	6-3/8	4-1/4	344025A
3	3-1/2	7	4-5/8	344030A
4	4-21/32	9-5/16	6-1/8	344040A

HEX NUT INCLUDED

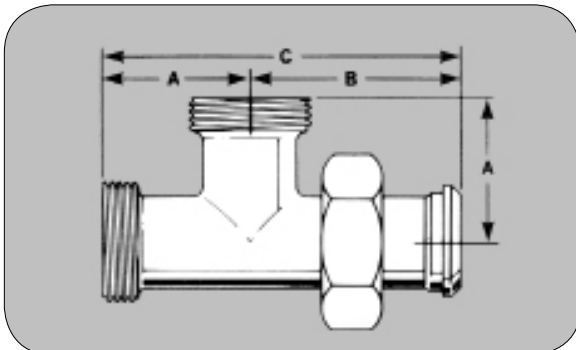

7B TEE (3A)

SIZE (TUBE O.D.)	A	B	C	STOCK NO.
1	1-13/16	2-11/16	4-1/2	344010B
1-1/2	2-3/8	3-13/32	5-25/32	344015B
2	2-25/32	3-13/16	6-19/32	344020B
2-1/2	3-3/16	4-1/4	7-7/16	344025B
3	3-1/2	4-5/8	8-1/8	344030B
4	4-21/32	6-1/8	10-25/32	344040B

HEX NUT INCLUDED

14PRF SHORT WELD FERRULE (3A)

SIZE (TUBE O.D.)	A	B	C	D	STOCK NO.
1	11/16	1-5/16	55/64	1	344110B
1-1/2	23/32	1-27/32	1-23/64	1-1/2	344115B
2	23/32	2-3/8	1-55/64	2	344120B
2-1/2	27/32	2-29/32	2-23/64	2-1/2	344125B
3	29/32	3-7/16	2-55/64	3	344130B
4	1-7/32	4-1/2	3-13/16	4	344140B

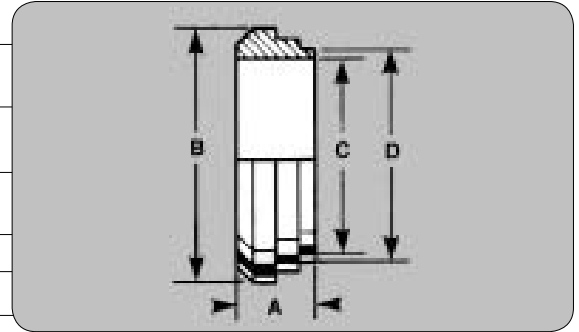

14R-PLAIN RECESSLESS FERRULE (3A)

(For Expanding)

SIZE (TUBE O.D.)	A	B	STOCK NO.
1	3/4	1	344110R
1-1/2	1-1/8	1-1/2	344115R
2	1-5/16	2	344120R
2-1/2	1-3/8	2-1/2	344125R
3	1-7/16	3	344130R
4	1-1/2	4	344140R

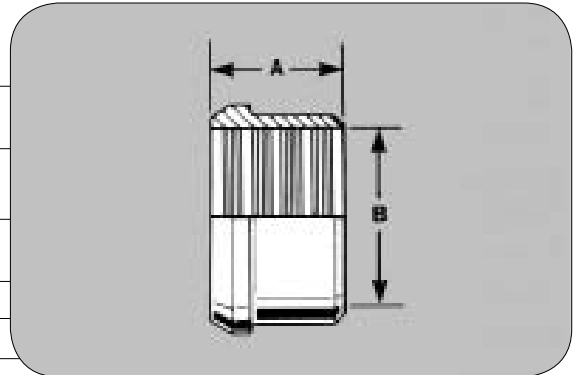

L14A7-PLAIN TUBE FERRULE (3A)

SIZE (TUBE O.D.)	A	B	C	STOCK NO.
1	1-3/8	29/32	1	344110A
1-1/2	1-1/2	1-13/32	1-1/2	344115A
2	1-1/2	1-7/8	2	344120A
2-1/2	1-3/4	2-3/8	2-1/2	344125A
3	1-3/4	2-7/8	3	344130A
4	1-3/4	3-27/32	4	344140A

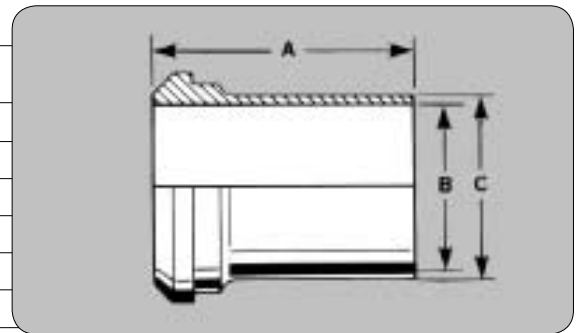

14W-PLAIN FERRULE, TANK SPUD (HEAVY) (3A)

SIZE (TUBE O.D.)	A	B	C	STOCK NO.
1	2-3/8	29/32	1-5/32	344110W
1-1/2	2-17/32	1-13/32	1-43/64	344115W
2	2-25/32	1-7/8	2-3/16	344120W
2-1/2	3-1/16	2-3/8	2-45/64	344125W
3	3-17/32	2-7/8	3-7/32	344130W
4	4-5/16	3-13/16	4-1/4	344140W

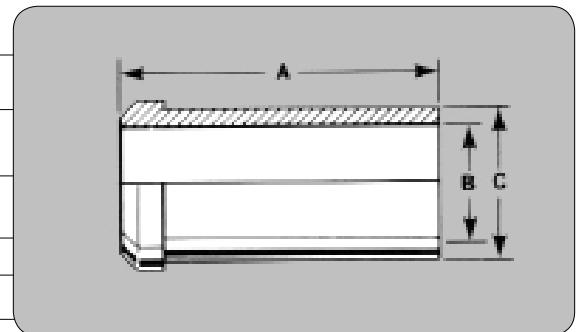

14WL-PLAIN FERRULE, TANK SPUD (LIGHT) (3A)

SIZE (TUBE O.D.)	A	B	C	STOCK NO.
1	2	29/32	1	344110WL
1-1/2	2-1/4	1-13/32	1-1/24	344115WL
2	2-1/2	1-7/8	2	344120WL
2-1/2	2-3/4	2-3/8	2-1/2	344125WL
3	3	2-7/8	3	344130WL
4	4	3-27/32	4	344140WL

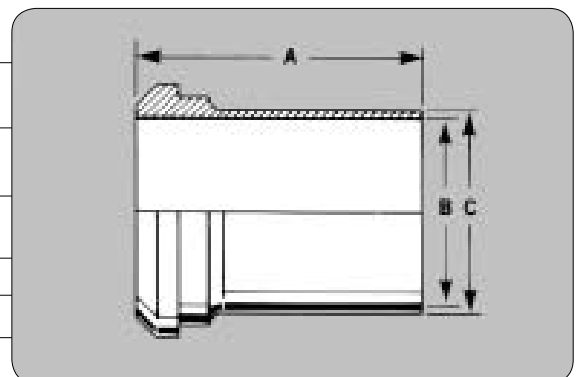

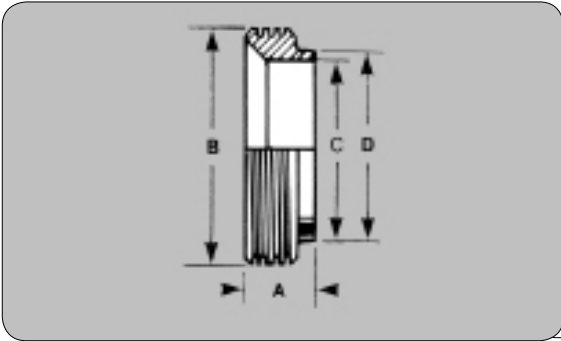

15TRF SHORT WELD FERRULE (3A)

SIZE (TUBE O.D.)	A	B	C	D	STOCK NO.
1	11/16	1-29/32	55/64	1	344210B
1-1/2	23/32	1-63/64	1-23/64	1-1/2	344215B
2	23/32	2-33/64	1-55/64	2	344220B
2-1/2	27/32	3-1/32	2-23/64	2-1/2	344225B
3	29/32	3-9/16	2-55/64	3	344230B
4	1-7/32	4-43/64	3-13/16	4	344240B

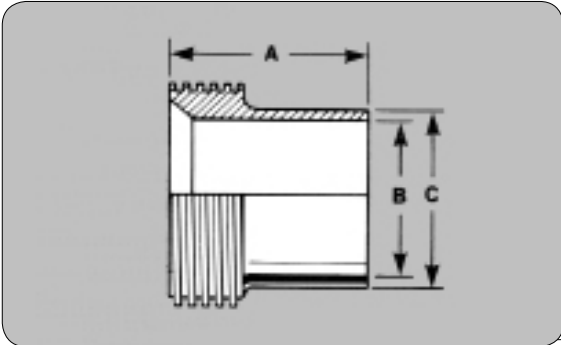

L15A7 THREADED TUBE FERRULE (3A)

SIZE (TUBE O.D.)	A	B	C	STOCK NO.
1	1-3/8	29/32	1	344210A
1-1/2	1-1/2	1-13/32	1-1/2	344215A
2	1-1/2	1-7/8	2	344220A
2-1/2	1-3/4	2-3/8	2-1/2	344225A
3	1-3/4	2-7/8	3	344230A
4	1-3/4	3-27/32	4	344240A

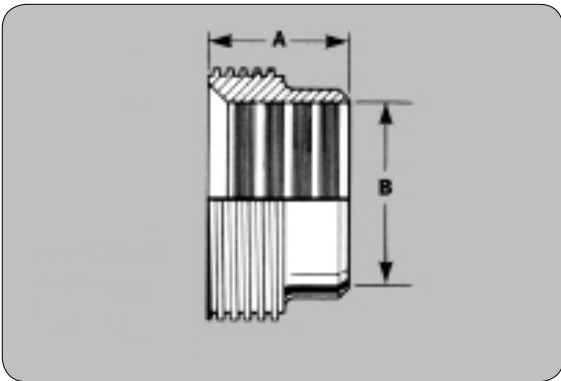

15R-THREADED RECESSLESS FERRULE (3A)
(For Expanding)

SIZE (TUBE O.D.)	A	B	STOCK NO.
1	13/16	1	344210R
1-1/2	1-1/8	1-1/2	344215R
2	1-3/8	2	344220R
2-1/2	1-1/2	2-1/2	344225R
3	1-5/8	3	344230R
4	1-5/8	4	344240R

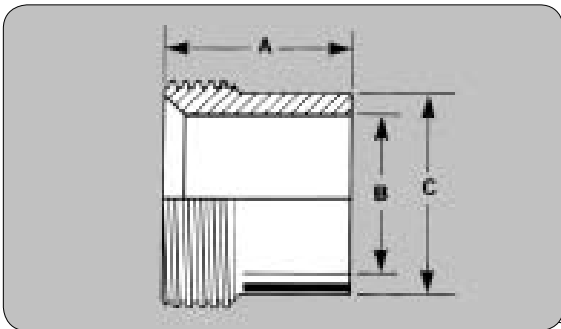

15W-THREADED FERRULE, TANK SPUD (HEAVY) (3A)

SIZE (TUBE O.D.)	A	B	C	STOCK NO.
1	1-1/2	29/32	1-1/4	344210W
1-1/2	1-5/8	1-13/32	1-3/4	344215W
2	1-3/4	1-7/8	2-5/16	344220W
2-1/2	1-3/4	2-3/8	2-7/8	344225W
3	1-13/16	2-7/8	3-3/8	344230W
4	2-1/8	3-27/32	4-1/4	344240W

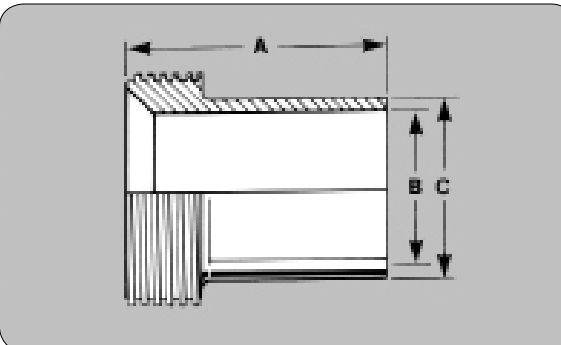

15WL-THREADED FERRULE, TANK SPUD (LIGHT) (3A)

SIZE (TUBE O.D.)	A	B	C	STOCK NO.
1	2	29/32	1	344210WL
1-1/2	2-1/4	1-13/32	1-1/2	344215WL
2	2-1/2	1-7/8	2	344220WL
2-1/2	2-3/4	2-3/8	2-1/2	344225WL
3	3	2-7/8	3	344230WL
4	4	3-27/32	4	344240WL

16A SOLID END CAP (3A)

SIZE (TUBE O.D.)	A	STOCK NO.
1	1-5/16	346810
1-1/2	1-27/32	346815
2	2-3/8	346820
2-1/2	2-29/32	346825
3	3-7/16	368230
4	4-1/2	346840

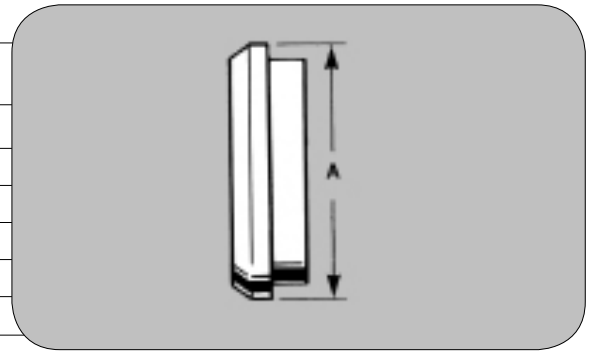

31-14F-CONVERTING TAPER REDUCER (3A)

SIZE (TUBE O.D.)	A	STOCK NO.
1-1/2 X 1	4-3/32	344515
2 X 1	6-3/32	344520
2 X 1-1/2	4-7/32	344520A
2-1/2 X 1-1/2	6-11/32	344525
2-1/2 X 2	4-7/32	344525A
3 X 2	6-13/32	344530
3 X 2-1/2	4-19/32	344530A
4 X 2-1/2	8-31/32	344540
4 X 3	6-31/32	344540A

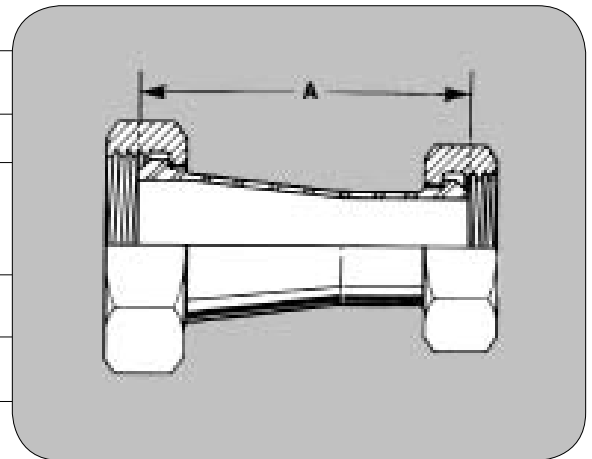

HEX NUTS INCLUDED

31-15F-CONCENTRIC TAPER REDUCER (3A)

SIZE (TUBE O.D.)	A	STOCK NO.
1-1/2 X 1	3-13/32	344615
2 X 1	5-13/32	344620
2 X 1-1/2	3-7/16	344620A
2-1/2 X 1-1/2	5-9/16	344625
2-1/2 X 2	3-9/16	344625A
3 X 2	5-5/8	344630
3 X 2-1/2	3-3/4	344630A
4 X 2-1/2	8-1/16	344640
4 X 3	6-1/8	344640A

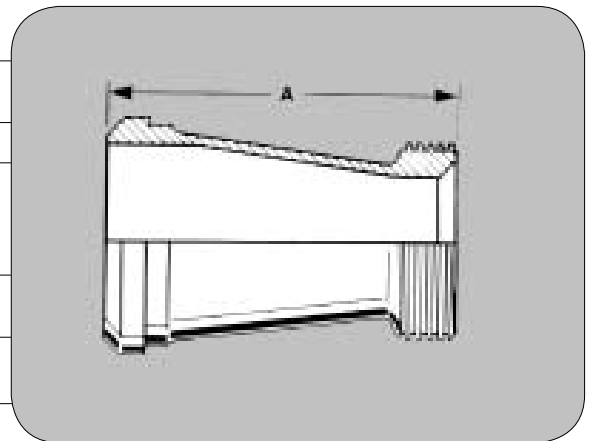

31-18F-TAPER REDUCER-ADAPTER

SIZE (TUBE O.D.)	A	STOCK NO.
1-1/2 X 1	4-1/16	344715
2 X 1	6-1/16	344720
2 X 1-1/2	4-11/32	344720A
2-1/2 X 1-1/2	6-15/32	344725
2-1/2 X 2*	4-3/8	344725A
3 X 2	6-7/16	344730
3 X 2-1/2*	4-27/32	344730A
4 X 2-1/2	9-5/32	344740
4 X 3	7-13/32	344740A

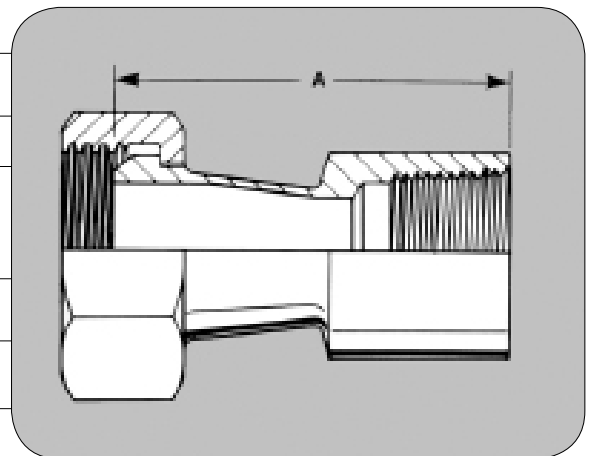

*HEX NUT INCLUDED ON THESE SIZES ONLY

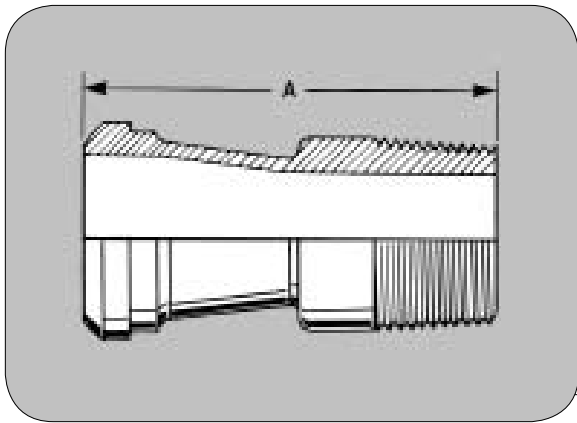

31-19F-TAPER REDUCER-ADAPTER

SIZE (TUBE O.D.)	A	STOCK NO.
1-1/2 X 1	4-15/32	344815
2 X 1	6-15/32	344820
2 X 1-1/2	4-15/32	344820A
2-1/2 X 1-1/2	6-19/32	344825
2-1/2 X 2	4-21/32	344825A
3 X 2	6-23/32	344830
3 X 2-1/2	5-7/32	344830A
4 X 2-1/2	9-17/32	344840
4 X 3	7-23/32	344840A

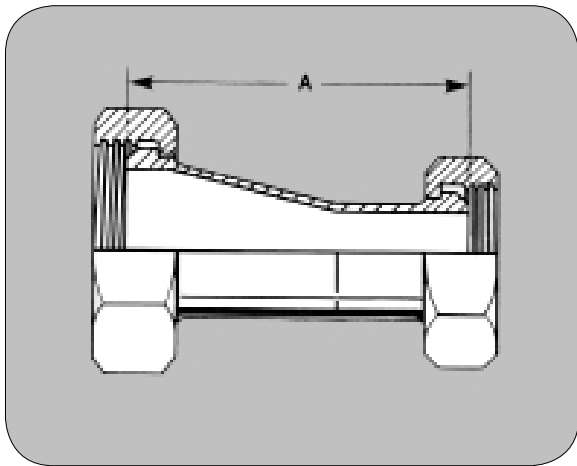

32-14F-ECCENTRIC TAPER REDUCER (3A)

SIZE (TUBE O.D.)	A	STOCK NO.
1-1/2 X 1	4-3/32	344915
2 X 1	6-3/32	344920
2 X 1-1/2	4-7/32	344920A
2-1/2 X 1-1/2	6-11/32	344925
2-1/2 X 2	4-7/32	344925A
3 X 2	6-13/32	344930
3 X 2-1/2	4-19/32	344930A
4 X 2-1/2	8-31/32	344940
4 X 3	6-31/32	344940A

HEX NUTS INCLUDED

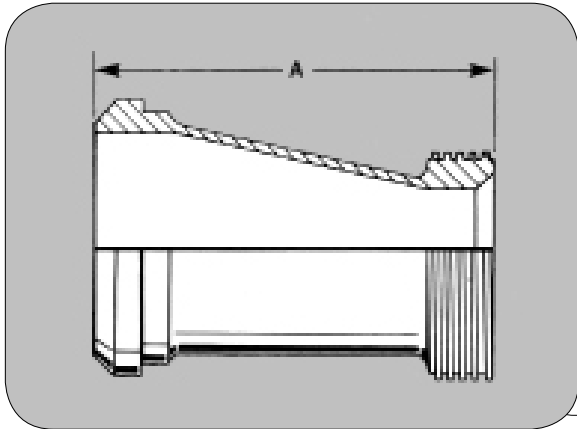

32-15F-ECCENTRIC TAPER REDUCER (3A)

SIZE (TUBE O.D.)	A	STOCK NO.
1-1/2 X 1	3-13/32	345015
2 X 1	5-13/32	345020
2 X 1-1/2	3-7/16	345020A
2-1/2 X 1-1/2	5-9/16	345025
2-1/2 X 2	3-9/16	345025A
3 X 2	5-5/8	345030
3 X 2-1/2	3-3/4	345030A
4 X 2-1/2	8-1/16	345040
4 X 3	6-1/8	345040A

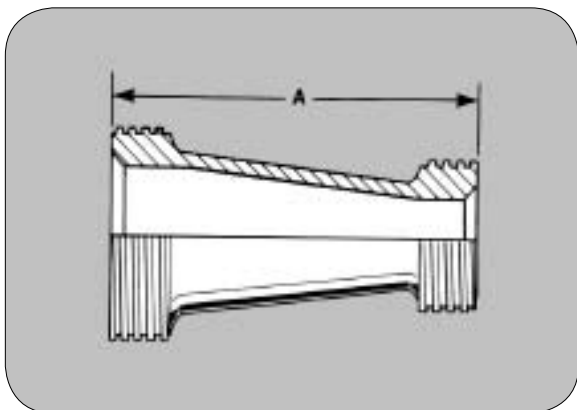

31TT-REDUCER (3A)

SIZE (TUBE O.D.)	A	STOCK NO.
1-1/2 X 1	3-13/32	345115
2 X 1	3-25/32	345120
2 X 1-1/2	3-7/16	345120A
2-1/2 X 1-1/2	3-29/32	345125
2-1/2 X 2	3-9/16	345125A
3 X 2	5-5/8	345130
3 X 2-1/2	5-13/32	345130A

31TP-TAPER REDUCER (3A)

SIZE (TUBE O.D.)	A	STOCK NO.
1-1/2 X 1	4-1/16	345215
2 X 1	4-1/16	345220
2 X 1-1/2	4-7/32	345220A
2-1/2 X 1-1/2	6-7/32	345225
2-1/2 X 2	4-7/32	345225A
3 X 2	6-9/32	345230
3 X 2-1/2	4-19/32	345230A

HEX NUT INCLUDED

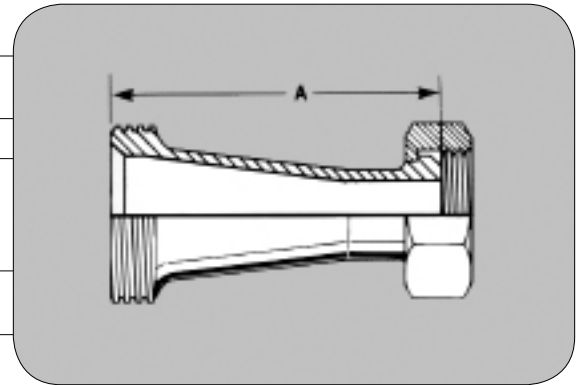

14-18 ADAPTER (Acme Hex Nut to Female NPT)

SIZE (TUBE O.D.)	A	STOCK NO.
1	3-1/8	345410
1-1/2	3-1/4	345415
2	3-5/16	345420
2-1/2	4-1/16	345425
3	4-1/4	345430
4	4-5/16	345440

HEX NUT INCLUDED

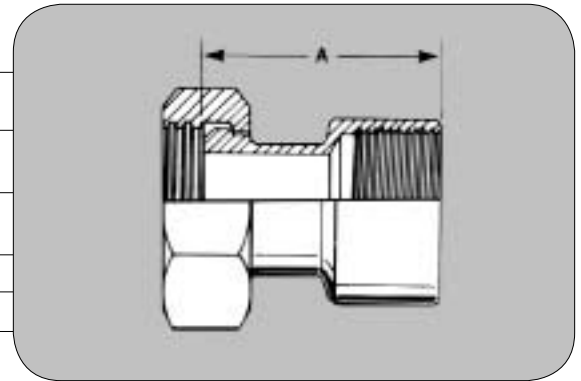

14-19 ADAPTER (Acme Hex Nut to Male NPT)

SIZE (TUBE O.D.)	A	STOCK NO.
1	3-1/8	345510
1-1/2	3-1/4	345515
2	3-5/16	345520
2-1/2	4-1/16	345525
3	4-1/4	345530
4	4-5/16	345540

HEX NUT INCLUDED

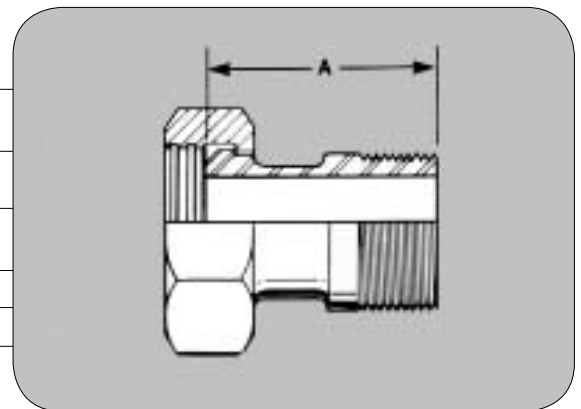

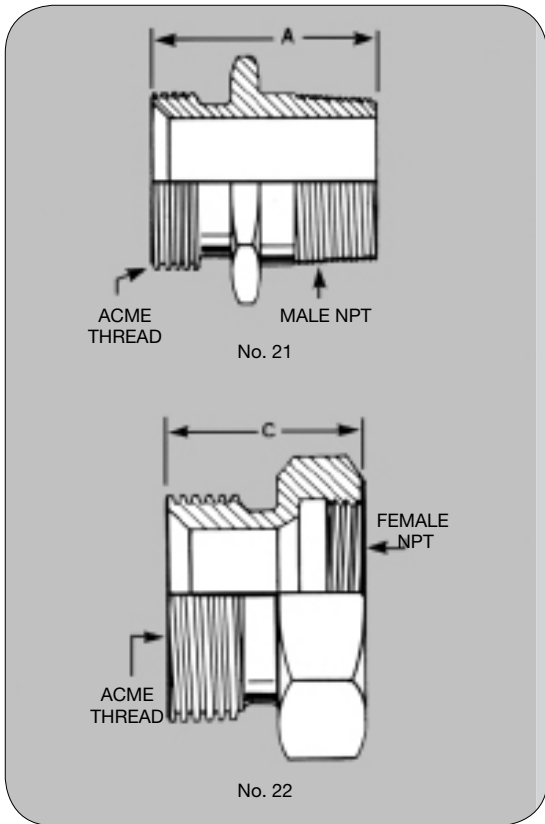

21 AND 22-ADAPTERS

SIZE (TUBE O.D.)	NO. 21 A	NO. 22 C	STOCK NO. NO. 21	STOCK NO. NO. 22
1 X 3/4	2-3/16	1-5/8	345610	345710
1 X 1	2-1/4	2-1/16	345610A	345710A
1 X 1-1/2	2-3/8	2-1/2	345610B	345710B
1 X 2	2-5/8	2-1/2	345610C	345710C
1-1/2 X 3/4	2-3/16	1-5/8	345615	345715
1-1/2 X 1	2-5/16	1-5/8	345615A	345715A
1-1/2 X 1-1/4	2-7/16	2-1/2	345615B	345715B
1-1/2 X 1-1/2	2-7/16	2-1/4	345615C	345715C
1-1/2 X 2	2-5/8	2-1/2	345615D	345715D
2 X 1-1/4	2-15/32	1-21/32	345620	345720
2 X 1-1/2	2-15/32	1-21/32	345620A	345720A
2 X 2	2-21/32	2-11/32	345620B	345720B
2 X 2-1/2	3-1/8	1-27/32	345620C	345720C
2-1/2 X 1	2-21/32	1-27/32	345625	345725
2-1/2 X 1-1/2	2-25/32	1-27/32	345625A	345725A
2-1/2 X 2	2-25/32	1-27/32	345625B	345725B
2-1/2 X 2-1/2	3-9/32	2-3/32	345625C	345725C
3 X 3	3-1/2	2-3/16	345630	345730
4 X 4	3-13/16	2-5/8	345640	345740

NOTE: SANITARY SIZE SHOWN FIRST

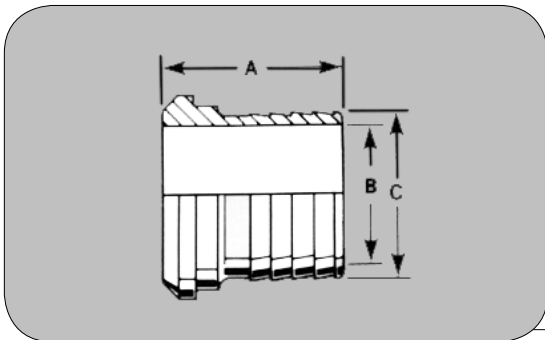

14AHR-RUBBER HOSE ADAPTER

SIZE (TUBE O.D.)	A	B	C	STOCK NO.
1	1-11/16	13/16	1	345810
1-1/2	1-11/16	1-5/16	1-1/2	345815
2	2-5/16	1-13/16	2	345820
2-1/2	2-11/32	2-5/16	2-1/2	345825
3	3-1/2	2-13/16	3	345830
4	4	3-13/16	4	345840

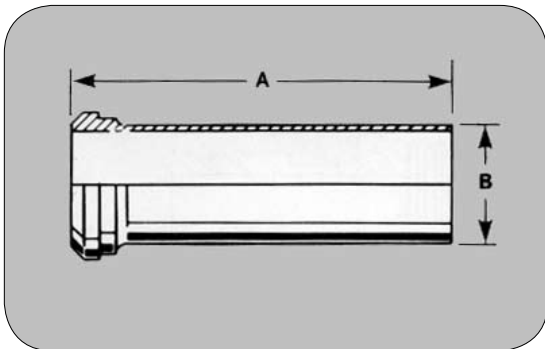

14AHT-TYGON HOSE ADAPTER

SIZE (TUBE O.D.)	A	B	STOCK NO.
1	4-11/16	1	345910
1-1/2	4-23/32	1-1/2	345915
2	4-23/32	2	345920
2-1/2	4-27/32	2-1/2	345925
3	4-29/32	3	345930
4	5-7/32	4	345940

15AHR-RUBBER HOSE ADAPTER

SIZE (TUBE O.D.)	A	B	C	STOCK NO.
1	1-11/16	13/16	1	346010
1-1/2	1-11/16	1-5/16	1-1/2	346015
2	2-5/16	1-13/16	2	346020
2-1/2	3	2-5/16	2-1/2	346025
3	3-1/2	2-13/16	3	346030
4	4	3-13/16	4	346040

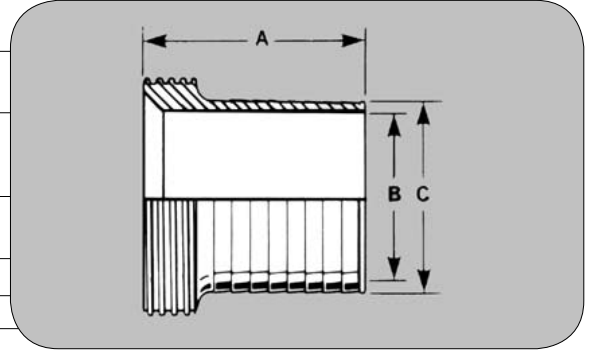

15AHT-TYGON HOSE ADAPTERS

SIZE (TUBE O.D.)	A	B	STOCK NO.
1	4-11/16	1	346110
1-1/2	4-23/32	1-1/2	346115
2	4-23/32	2	346120
2-1/2	4-27/32	2-1/2	346125
3	4-29/32	3	346130
4	5-7/32	4	346140

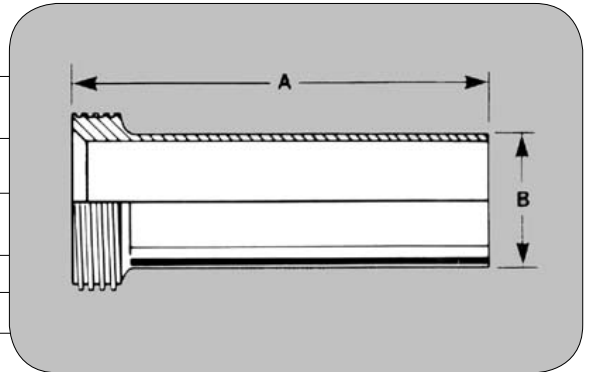

25H ALUMINUM HEX WRENCH-SINGLE END

SIZE	STOCK NO.
1	346610
1-1/2	346615
2	346620
2-1/2	346625
3	346630
4	346640

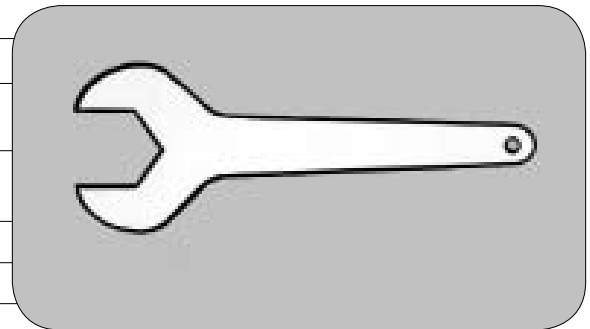

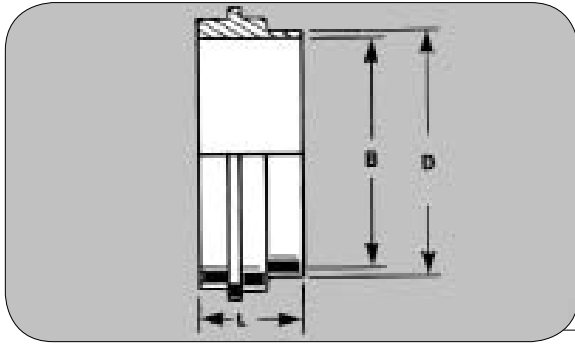

14PRFJP SHORT WELD FERRULE-JOHN PERRY (3A)

SIZE (TUBE O.D.)	D	B	L	STOCK NO.
1	1	.870	11/16	3641B10
1-1/2	1-1/2	1.370	23/32	3641B15
2	2	1.870	23/32	3641B20
2-1/2	2-1/2	2.370	27/32	3641B25
3	3	2.870	29/32	3641B30
4	4	3.834	1-7/32	3641B40

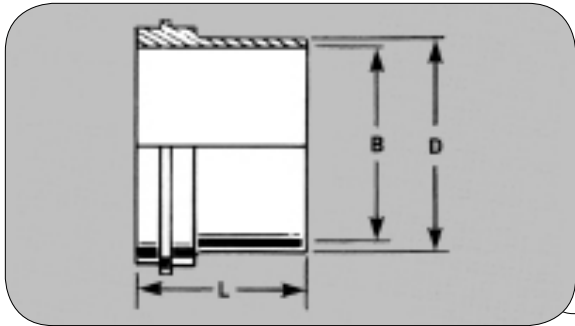

L14AJP PLAIN TUBE FERRULE-JOHN PERRY (3A)

SIZE (TUBE O.D.)	D	B	L	STOCK NO.
1	1	.870	1-3/8	3641A10
1-1/2	1-1/2	1.370	1-1/2	3641A15
2	2	1.870	1-1/2	3641A20
2-1/2	2-1/2	2.370	1-3/4	3641A25
3	3	2.870	1-3/4	3641A30
4	4	3.834	1-3/4	3641A40

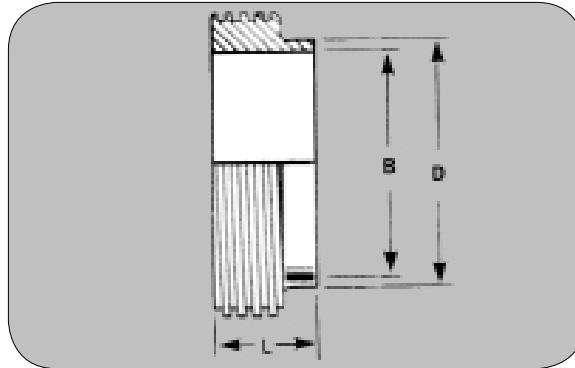

15TRFJP SHORT WELD FERRULE-JOHN PERRY (3A)

SIZE (TUBE O.D.)	D	B	L	STOCK NO.
1	1	.870	11/16	3642B10
1-1/2	1-1/2	1.370	23/32	3642B15
2	2	1.870	23/32	3642B20
2-1/2	2-1/2	2.370	27/32	3642B25
3	3	2.870	29/32	3642B30
4	4	3.834	1-7/32	3642B40

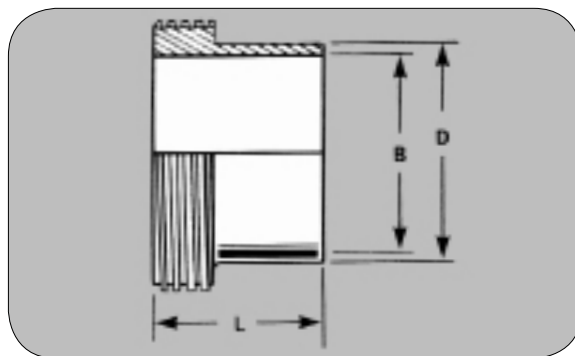

L15AJP THREADED TUBE FERRULE-JOHN PERRY (3A)

SIZE (TUBE O.D.)	D	B	L	STOCK NO.
1	1	.870	1-3/8	3642A10
1-1/2	1-1/2	1.370	1-1/2	3642A15
2	2	1.870	1-1/2	3642A20
2-1/2	2-1/2	2.370	1-3/4	3642A25
3	3	2.870	1-3/4	3642A30
4	4	3.834	1-3/4	3642A40

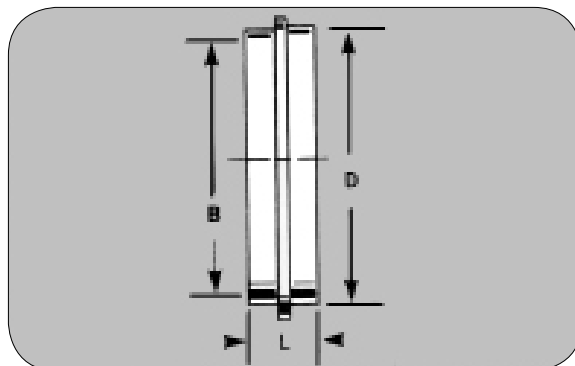

16AJP END CAP-JOHN PERRY (3A)

SIZE (TUBE O.D.)	D	B	L	STOCK NO.
1	1	1.325	15/32	366510
1-1/2	1-1/2	1.856	31/64	366515
2	2	2.387	17/32	366520
2-1/2	2-1/2	2.856	35/64	366525
3	3	3.387	39/64	366530
4	4	4.387	11/16	366540

TOP LINE

PROCESS EQUIPMENT COMPANY

... the source for
all your product needs
in the process industries

Contact your Top Line Representative for Assistance

Office: P.O. Box 264 · Bradford, PA 16701

Plant: 21 Valley Hunt Drive · Lewis Run, PA 16738

800-458-6095

814-362-4626

Fax: 814-362-4453

PUMPS & STRAINERS- Centrifugal, Rotary Lobe, Filters and Strainers



VALVES - Manual, Actuated, Diaphragm



FITTINGS - Clamp, Sanitary Butt Weld, Bevel Seat, Tube OD Butt weld, Custom, Biopharm



TUBING, GAUGES, SIGHT GLASSES, BRAIDED HOSE



www.toplineonline.com