



Clamp Fittings



Stainless Steel Flow Control Equipment for the
Food, Beverage, Dairy, Cosmetics, Biotechnology,
Pharmaceutical and Electronics Processing Industries

Clamp Fittings

Top Line has been supplying high quality stainless steel products to the dairy, food, beverage, pharmaceutical and other process industries for over forty years. Our commitment to fine craftsmanship, responsible service and realistic pricing has led to our company's successive years of growth.

Top Line specializes in stainless steel materials – types 304, 316, and "L grades". In addition, Top Line can also manufacture fittings in AL6XN, Titanium, Haselloy C, or other alloys if required.

Our modern, well-equipped manufacturing facilities are staffed by our skilled and dedicated craftsmen. Consistently meeting important tolerances and finish specifications is of primary concern to us. Before any products leave our plant they are subjected to rigid quality assurance checks.

Top Line should always be considered your first choice for both standard and custom fabricated stainless steel products.



Top Line precision crafted Clamp Fittings provide fast, sanitary and secure connections. Polished fittings meet or exceed FDA and 3A regulatory standards.

Clamp Fittings Specifications

- Size Range: 1" OD through 4" OD
- Materials: 304 (Stock No. Prefix 32)
316L (Stock No. Prefix 38)
- Finish: No. 7 – ID and OD (standard)
No. 5 – OD only (special)
No. 3 – ID only (special)
No. 1 – unpolished (special)

Polish specifications: 3A fittings meet or exceed 180 grit ID (32 Ra) and 150 grit OD.

Ordering Specifications

- Specify:
- Quantity
 - Size
 - Product Description
 - Stock Number
 - Material Type
 - Polish Requirements

Example

Quantity	Size	Product Description	Stock Number	Material Type	Polish
↕	↕	↕	↕	↕	↕
<u>3 Each</u>	<u>2"</u>	<u>2CMP-90°</u>	<u>#32720-7</u>	<u>Type 304</u>	<u>No. 7</u>
<u>3 Each</u>	<u>2"</u>	<u>2CMP-90°</u>	<u>#38720-7</u>	<u>Type 316</u>	<u>No. 7</u>

LIMITED WARRANTY

Top Line Process Equipment Company products are warranted to be free of defects in material or workmanship for a period of one year from date of shipment. Warranty covers those Top Line products used in an approved installation and maintained in strict accordance with recognized standard industry practice. If, after properly authorized return, Top Line determines that products are defective, Top Line may at its option, repair or replace such defective products.

Top Line shall not be liable for consequential, indirect or incidental damages. The above warranty is in lieu of all other warranties, expressed or implied.

*Styles and dimensions are subject to change without notice.

2CMP 90° ELL (3A)

SIZE (TUBE O.D.)	A	R	STOCK NO.
1	2	1-1/2	32710
1-1/2	2-3/4	2-1/4	32715
2	3-1/2	3	32720
2-1/2	4-1/4	3-3/4	32725
3	5	4-1/2	32730
4	6-5/8	6	32740

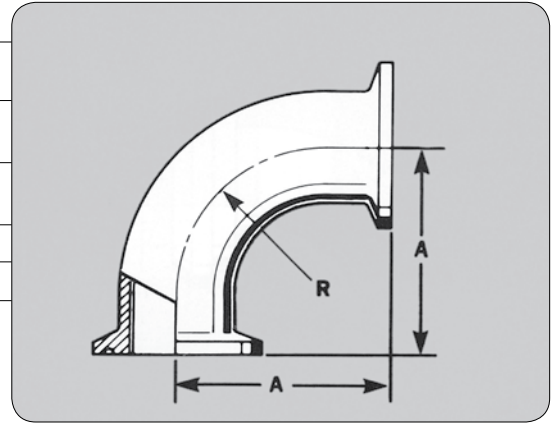

2FMP-14 90° SWEEP ELL (3A)

SIZE (TUBE O.D.)	A	B	STOCK NO.
1	2	2-3/16	327010
1-1/2	2-3/4	2-31/32	327015
2	3-1/2	3-23/32	327020
2-1/2	4-1/4	4-19/32	327025
3	5	5-13/32	327030
4	6-5/8	7-7/32	327040

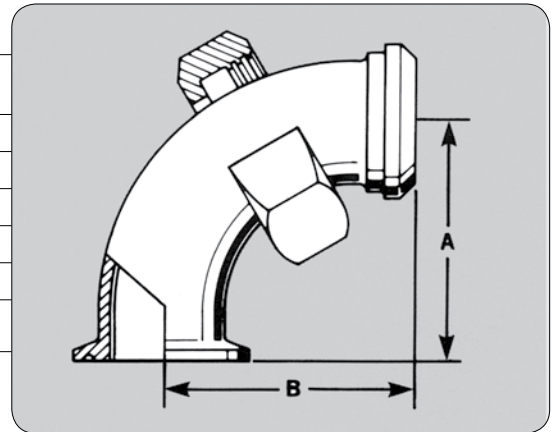

2FMP-15 90° SWEEP ELL (3A)

SIZE (TUBE O.D.)	A	B	STOCK NO.
1	2	1-7/8	327110
1-1/2	2-31/32	2-3/4	327115
2	3-23/32	3-1/2	327120
2-1/2	4-19/32	4-1/4	327125
3	5-13/32	5	327130
4	7-7/32	6-5/8	327140

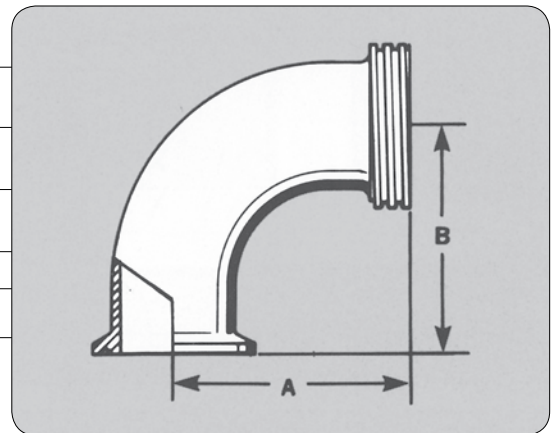

2CMP-31MP 90° CONCENTRIC REDUCING ELL

SIZE (TUBE O.D.)	A	B	STOCK NO.
2 X 1	2	2	327220
2 X 1	2-3/4	2-3/4	327220A
2-1/2 X 1	2-3/4	2-3/4	327225
2-1/2 X 2	3-1/2	3-1/2	327225A
3 X 1-1/2	2-3/4	2-3/4	327230
3 X 2	3-1/2	3-1/2	327230A
3 X 2-1/2	4-1/4	4-1/4	327230B
4 X 2-1/2	4-1/4	4-1/4	327240
4 X 3	5	5	327240A

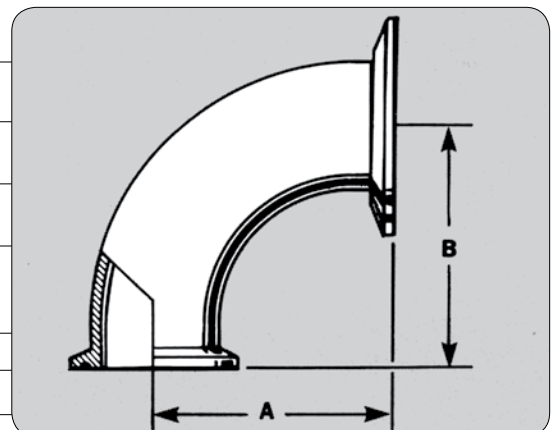

NOTE: 1" CLAMP FITTINGS USE 1-1/2" CLAMPS

ELBOWS & TEES

CLAMP FITTINGS



2FMP-31MP 90° ELL(3A)

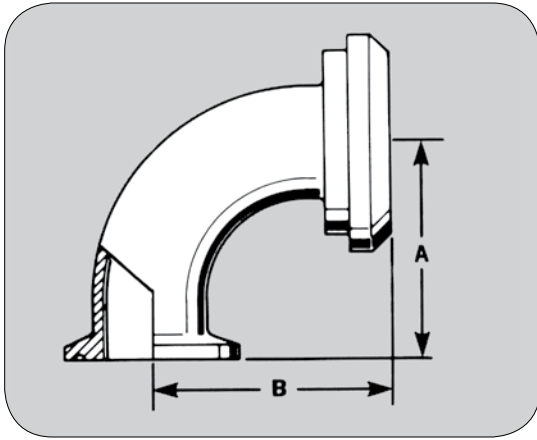

SIZE (TUBE O.D.)	A	B	STOCK NO.
2 X 1	2	1-9/16	327420
2 X 1-1/2	2-3/4	2-5/16	327420A
2-1/2 X 1-1/2	2-3/4	2-5/16	327425
2-1/2 X 2	3-1/2	3-1/16	327425A
3 X 1-1/2	2-3/4	2-5/16	327430
3 X 2	3-1/2	3-1/16	327430A
3 X 2-1/2	4-1/4	3-13/16	327430B
4 X 2-1/2	4-1/4	3-13/16	327440
4 X 3	5	4-9/16	327440A

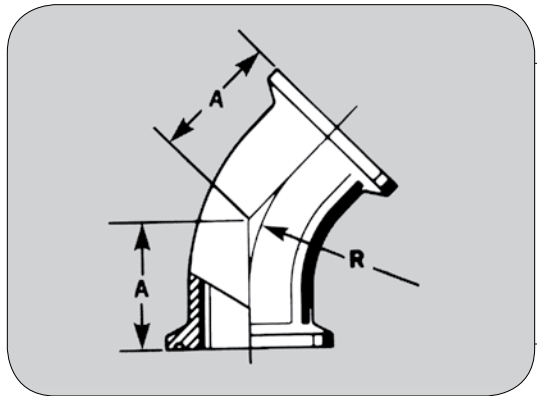

2KMP 45° ELL (3A)

SIZE (TUBE O.D.)	A	R	STOCK NO.
1	1-1/8	1-1/2	32810
1-1/2	1-7/16	2-1/4	32815
2	1-3/4	3	32820
2-1/2	2-1/16	3-3/4	32825
3	2-3/8	4-1/2	32830
4	3-1/8	6	32840

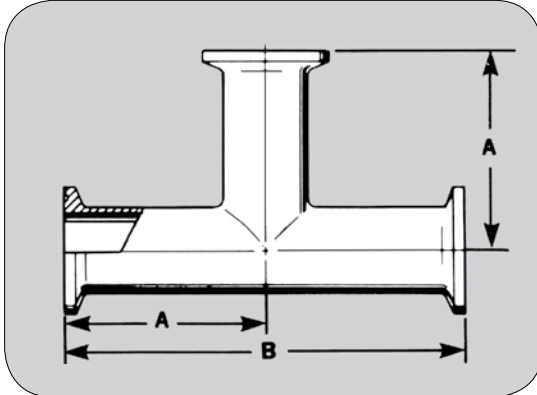

7MP TEE (3A)

SIZE (TUBE O.D.)	A	B	STOCK NO.
1	2-3/8	4-3/4	321110
1-1/2	2-3/4	5-1/2	321115
2	3-1/2	7	321120
2-1/2	3-1/2	7	321125
3	3-3/4	7-1/2	321130
4	4-1/2	9	321140

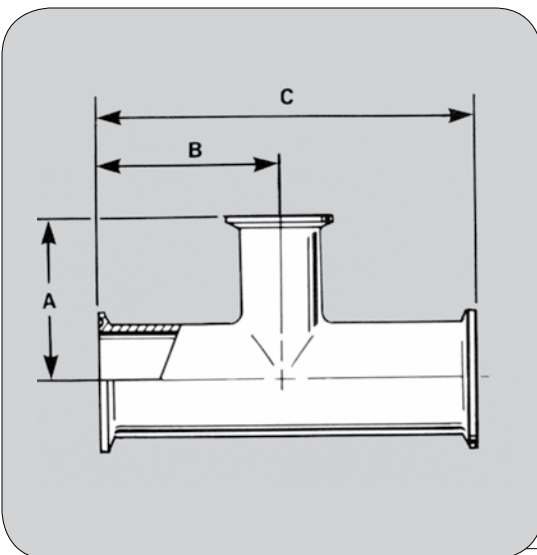

7RMP – REDUCING TEE (REDUCED SIZE ON BRANCH)

SIZE (TUBE O.D.)	A	B	C	STOCK NO.
1-1/2 X 1	1-7/8	2-5/32	4-5/16	321115R10
2 X 1	2-1/8	2-9/16	5-1/8	321120R10
2 X 1-1/2	2-13/32	2-9/16	5-1/8	321120R15
2-1/2 X 1	2-13/16	2-27/32	5-11/16	321125R10
2-1/2 X 1-1/2	2-13/16	3-27/32	5-11/16	321125R15
2-1/2 X 2	2-13/16	2-27/32	5-11/16	321125R20
3 X 1	3-1/16	3-3/32	6-3/16	321130R10
3 X 1-1/2	3-1/16	3-3/32	6-3/16	321130R15
3 X 2	3-1/16	3-3/32	6-3/16	321130R20
3 X 2-1/2	3-3/32	3-3/32	6-3/16	321130R25
4 X 1	4-7/8	4-1/16	8-1/8	321140R10
4 X 1-1/2	4-7/8	4-1/16	8-1/8	321140R15
4 X 2	4-7/8	4-1/16	8-1/8	321140R20
4 X 2-1/2	4-7/8	4-1/16	8-1/8	321140R25
4 X 3	4-7/8	4-1/16	8-1/8	321140R30

NOTE: 1" CLAMP FITTINGS USE 1-1/2" CLAMPS

9MP CROSS (3A)

SIZE (TUBE O.D.)	A	B	STOCK NO.
1	2-3/8	4-3/4	3210110
1-1/2	2-3/4	5-1/2	3210115
2	3-1/2	7	3210120
2-1/2	3-1/2	7	3210125
3	3-3/4	7-1/2	3210130
4	4-1/2	9	3210140

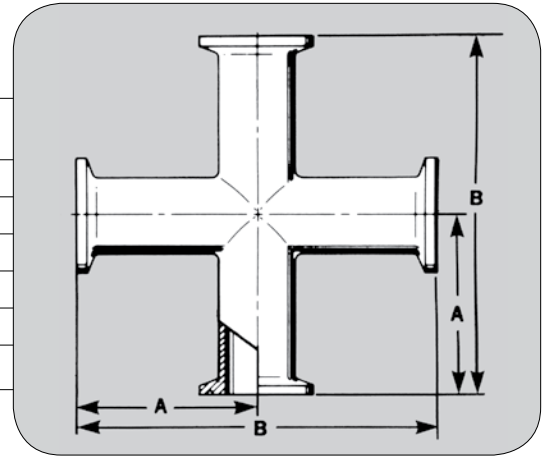

23BMP THERMOMETER CAP

SIZE (TUBE O.D.)	A	STOCK NO.
1	1.984	329810B
1-1/2	1.984	329815B
2	2.516	329820B
2-1/2	3.047	329825B
3	3.579	329830B
4	4.682	329840B

NOTE: 1" TAPPED 1/2" NPT; ALL OTHERS 3/4" NPT

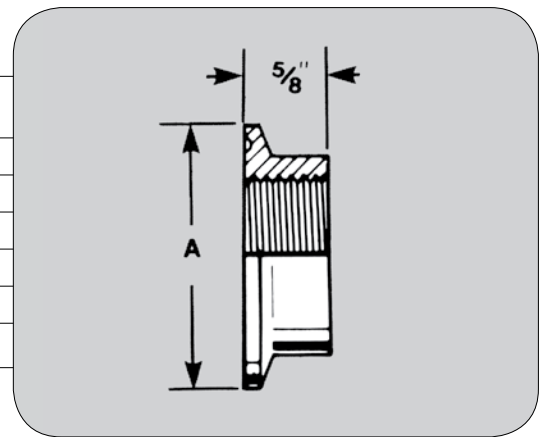

31RMP-REDUCING FERRULE-CONCENTRIC (3A)

SIZE (TUBE O.D.)	OVERALL LENGTH	STOCK NO.	SIZE (TUBE O.D.)	OVERALL LENGTH	STOCK NO.
1-1/2 X 1	3/4	329415	3 X 1	1-5/16	329430
2 X 1	3/4	329420	3 X 1-1/2	1-5/16	329430A
2 X 1-1/2	1-1/8	329420A	3 X 2	1-5/16	329430B
2-1/2 X 1	1-1/8	329425	3 X 2-1/2	1-3/8	329430C
2-1/2 X 1-1/2	1-1/8	329425A	4 X 2-1/2	1-3/8	329440
2-1/2 X 2	1-5/16	329425B	4 X 3	1-7/16	329440A

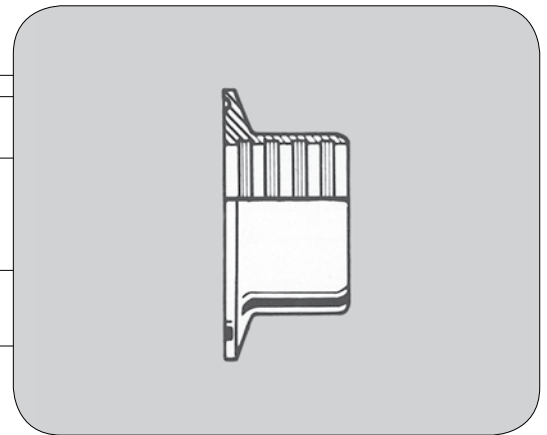

32RMP-REDUCING FERRULE-CONCENTRIC (3A)

SIZE (TUBE O.D.)	OVERALL LENGTH	STOCK NO.	SIZE (TUBE O.D.)	OVERALL LENGTH	STOCK NO.
1-1/2 X 1	3/4	329515	3 X 1	1-5/16	329530
2 X 1	3/4	329520	3 X 1-1/2	1-5/16	329530A
2 X 1-1/2	1-1/8	329520A	3 X 2	1-5/16	329530B
2-1/2 X 1	1-1/8	329525	3 X 2-1/2	1-3/8	325430C
2-1/2 X 1-1/2	1-1/8	329525A	4 X 2-1/2	1-3/8	329540
2-1/2 X 2	1-5/16	329525B	4 X 3	1-7/16	329540A

NOTE: 1" CLAMP FITTINGS USE 1-1/2" CLAMPS

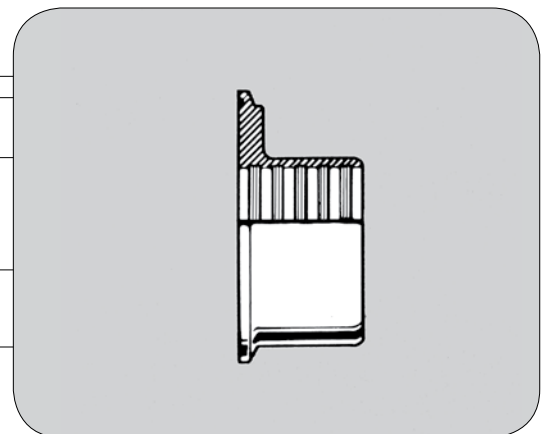

FERRULES

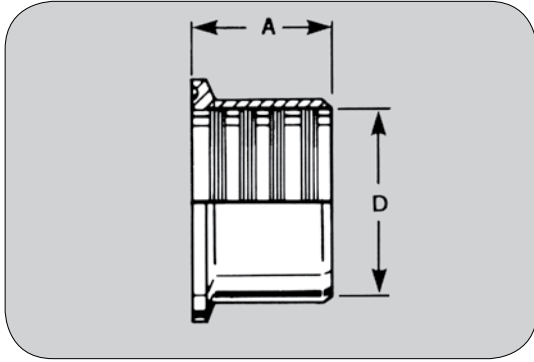

14RMP-RECESSLESS FERRULE (3A) (FOR EXPANDING)

SIZE (TUBE O.D.)	A	D	STOCK NO.
1	3/4	1	32110
1-1/2	1-1/8	1-1/2	32115
2	1-5/16	2	32120
2-1/2	1-3/8	2-1/2	32125
3	1-7/16	3	32130
4	1-1/2	4	32140

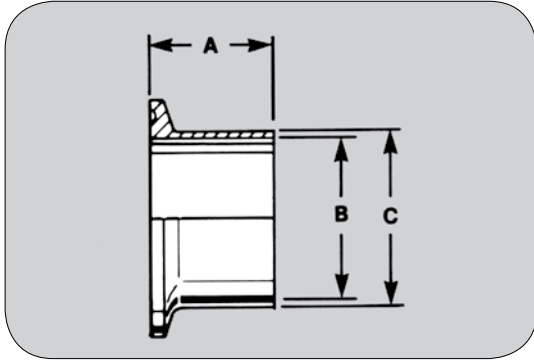

L14AM7 – BUTT WELDING FERRULE (3A)

SIZE (TUBE O.D.)	A	B	C	STOCK NO.
1	1-1/8	.870	1.000	327510
1-1/2	1-1/8	1.370	1.500	327515
2	1-1/8	1.870	2.000	327520
2-1/2	1-1/8	2.370	2.500	327525
3	1-1/8	2.870	3.000	327530
4	1-1/8	3.834	4.000	327540

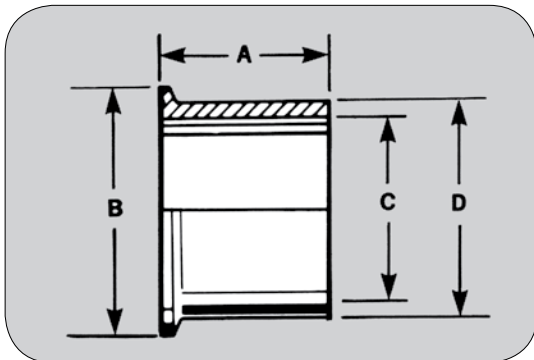

14MPW – TANK WELDING FERRULE (3A)

SIZE (TUBE O.D.)	A	B	C	D	STOCK NO.
1	1-5/8	1.984	.870	1.160	327610
1-1/2	1-5/8	1.984	1.370	1.676	327615
2	1-3/4	2.516	1.870	2.192	327620
2-1/2	1-3/4	3.047	2.370	2.708	327625
3	1-13/16	3.579	2.870	3.224	327630
4	2-1/8	4.682	3.834	4.256	327640

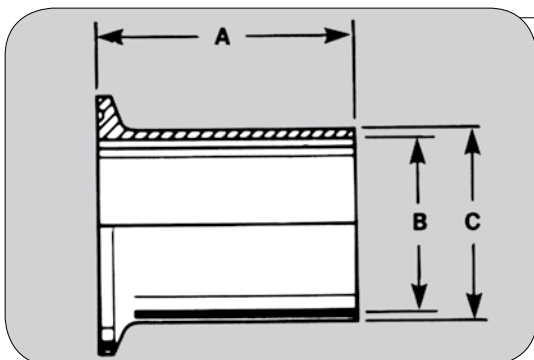

14WLMP – TANK WELDING SPUD-LIGHT (3A)

SIZE (TUBE O.D.)	A	B	C	STOCK NO.
1	3	.870	1.000	327710
1-1/2	3	1.370	1.500	327715
2	3	1.870	2.000	327720
2-1/2	3	2.370	2.500	327725
3	4	2.870	3.000	327730
4	4	3.834	4.000	327740

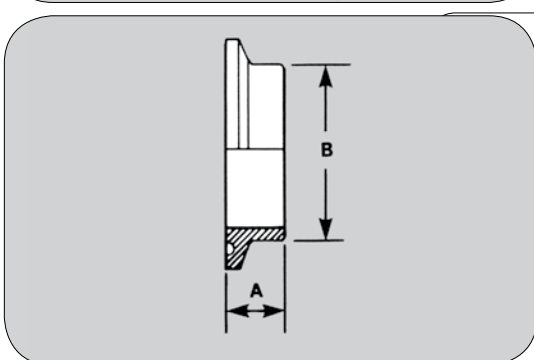

14WMP – SHORT WELDING FERRULE (3A)

SIZE (TUBE O.D.)	A	B	STOCK NO.
1	1/2	1.000	32210
1-1/2	1/2	1.500	32215
2	1/2	2.000	32220
2-1/2	1/2	2.500	32225
3	1/2	3.000	32230
4	5/8	4.000	32240
6	3/4	6.000	32260
8	7/8	8.000	32280

NOTE: 1" CLAMP FITTINGS USE 1-1/2" CLAMPS

14MPHR – RUBBER HOSE ADAPTER

SIZE (TUBE O.D.)	A	B	C	STOCK NO.
1	1-11/16	1.000	.812	327810
1-1/2	1-11/16	1.500	1.312	327815
2	2-5/16	2.000	1.810	327820
2-1/2	2-11/32	2.500	2.312	327825
3	3-3/32	3.000	2.834	327830
4	3-13/32	4.000	3.834	327840

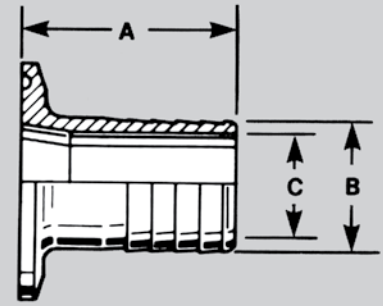

14MPHT – TYGON HOSE ADAPTER

SIZE (TUBE O.D.)	A	B	C	STOCK NO.
1	4-1/2	.870	1.000	327910
1-1/2	4-1/2	1.370	1.500	327915
2	4-1/2	1.870	2.000	327920
2-1/2	4-1/2	2.370	2.500	327925
3	4-1/2	2.870	3.000	327930
4	4-5/8	3.834	4.000	327940

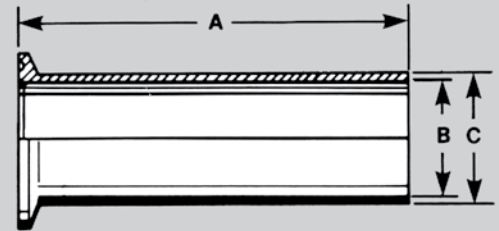

17MP-14 – ADAPTER (3A)

SIZE (TUBE O.D.)	A	STOCK NO.
1	3	328010
1-1/2	3	328015
2	3	328020
2-1/2	3-1/2	328025
3	3-3/4	328030
4	4	328040

HEX NUT INCLUDED

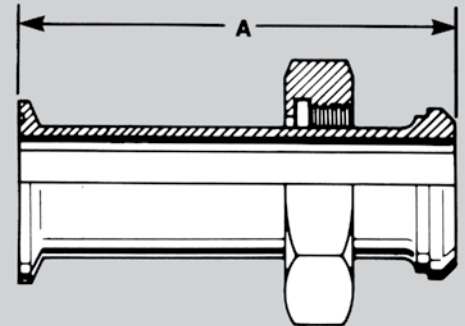

17MP-15 – ADAPTER (3A)

SIZE (TUBE O.D.)	A	STOCK NO.
1	1-11/16	328110
1-1/2	1-23/32	328115
2	1-23/32	328120
2-1/2	1-27/32	328125
3	1-29/32	328130
4	2-11/32	328140

NOTE: 1" CLAMP FITTINGS USE 1-1/2" CLAMPS

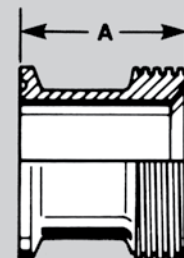

ADAPTERS & REDUCERS

21MP AND 22MP – ADAPTERS (N.P.T. THREADS)

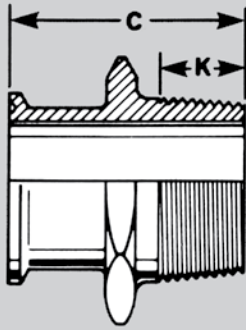

**21MP
(MALE)**



**22MP
(FEMALE)**

SIZE (TUBE O.D.)	NO. 21MP		NO. 22MP D	STOCK NUMBER	
	C	K		21MP	22MP
1 X 1/2	2-3/16	0.7815	1-5/8	3221005	32831005
1 X 3/4	2-3/16	0.7935	1-5/8	328210	328310
1 X 1	2-1/4	0.9845	1-5/8	328210A	328310A
1 X 1-1/4	2-7/16	1.0085	2-1/4	328210D	328310D
1 X 1-1/2	2-7/16	1.0252	2-1/4	328210B	328310B
1 X 2	2-5/8	1.0582	2-1/4	328210C	328310C
1-1/2 X 1/2	2-3/16	0.7815	1-5/8	32821505	32831505
1-1/2 X 3/4	2-3/16	0.7935	1-5/8	328215	328315
1-1/2 X 1	2-5/16	0.9845	1-5/8	328215A	328315A
1-1/2 X 1-1/4	2-7/16	1.0085	2-1/4	328215B	328315B
1-1/2 X 1-1/2	2-7/16	1.0252	2-1/4	328215C	328315C
1-1/2 X 2	2-5/8	1.0582	2-1/4	328215D	328315D
2 X 1/2	2-1/4	0.7815	1-11/16	32822005	32832005
2 X 3/4	2-9/32	0.7935	1-11/16	32822007	32832007
2 X 1	2-15/32	0.9845	1-11/16	328220D	32832010
2 X 1-1/4	2-15/32	1.0085	1-11/16	328220	328320
2 X 1-1/2	2-15/32	1.0252	1-11/16	328220A	328320A
2 X 2	2-21/32	1.0582	2-11/32	328220B	328320B
2 X 2-1/2	3-1/8	1.5712	2-13/32	328220C	328320C
2-1/2 X 1	2-25/32	0.9845	1-5/16	328225	328325
2-1/2 X 1-1/2	2-25/32	1.0252	1-21/32	328225A	328325A
2-1/2 X 2	2-25/32	1.0582	1-23/32	328225B	328325B
2-1/2 X 2-1/2	3-9/32	1.5712	1-23/32	328225C	328325C
3 X 2-1/2	3-1/2	1.5712	2-3/16	328230A	32833025
3 X 3	3-1/2	1.6337	2-3/16	328230	328330
4 X 2	3-13/16	1.0582	2-3/16	328240A	328340A
4 X 3	4-13/16	1.6337	2-3/16	328240B	328340B
4 X 4	3-13/16	1.7337	2-5/8	328240	328340

WHEN ADAPTER DIMENSIONS ARE GIVEN, SANITARY STYLE END IS ALWAYS INDICATED FIRST

31-14MP – CONCENTRIC REDUCER (3A)

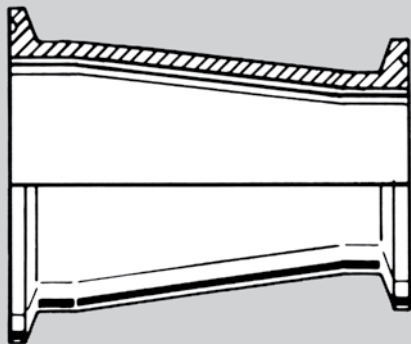

SIZE (TUBE O.D.)	OVERALL LENGTH	STOCK NO.
1-1/2 X 1	3	328415
2 X 1	5	328420
2 X 1-1/2	3	328420A
2-1/2 X 1	7	328425
2-1/2 X 1-1/2	5	328425A
2-1/2 X 2	3	328425B
3 X 1	9	32843010
3 X 1-1/2	7	328430

SIZE (TUBE O.D.)	OVERALL LENGTH	STOCK NO.
3 X 2	5	328430A
3 X 2-1/2	3	328430B
4 X 1	13-1/8	32844010
4 X 1-1/2	11-1/8	32844015
4 X 2	9-1/8	328440
4 X 2-1/2	7-1/8	328440A
4 X 3	5-1/8	328440B

32-14MP – ECCENTRIC REDUCER (3A)

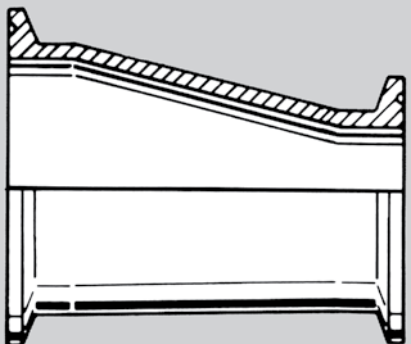

SIZE (TUBE O.D.)	OVERALL LENGTH	STOCK NO.
1-1/2 X 1	3	328515
2 X 1	5	328520
2 X 1-1/2	3	328520A
2-1/2 X 1	7	32852510
2-1/2 X 1-1/2	5	328525
2-1/2 X 2	3	328525A
3 X 1	9	32853010
3 X 1-1/2	7	328530

SIZE (TUBE O.D.)	OVERALL LENGTH	STOCK NO.
3 X 2	5	328530A
3 X 2-1/2	3	328530B
4 X 1	13-1/8	32854010
4 X 1-1/2	11-1/8	32854015
4 X 2	9-1/8	328540
4 X 2-1/2	7-1/8	328540A
4 X 3	5-1/8	328540B

NOTE: 1" CLAMP FITTINGS USE 1-1/2" CLAMPS

31TMP – ADAPTER - REDUCER - CONCENTRIC (3A)

SIZE (TUBE O.D.)	OVERALL LENGTH	STOCK NO.	SIZE (TUBE O.D.)	OVERALL LENGTH	STOCK NO.
1-1/2 X 1	3-7/32	329015	3 X 2	5-15/32	329030
2 X 1	5-7/32	329020	3 X 2-1/2	3-13/32	329030A
2 X 1-1/2	3-7/32	329020A	4 X 2-1/2	7-23/32	329040
2-1/2 X 1-1/2	5-11/32	329025	4 X 3	5-23/32	329040A
2-1/2 X 2	3-11/32	329025A			

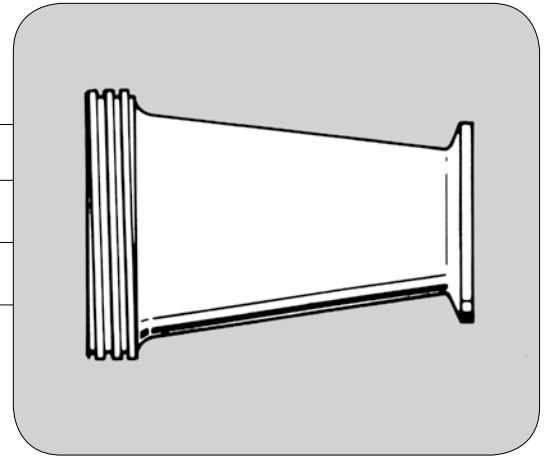

31MPT – ADAPTER-REDUCER-CONCENTRIC (3A)

SIZE (TUBE O.D.)	OVERALL LENGTH	STOCK NO.	SIZE (TUBE O.D.)	OVERALL LENGTH	STOCK NO.
1-1/2 X 1	3-3/16	329315	3 X 2	5-7/32	329330
2 X 1	5-3/16	329320	3 X 2-1/2	3-11/32	329330A
2 X 1-1/2	3-7/32	329320A	4 X 2-1/2	7-15/32	329340
2-1/2 X 1-1/2	5-7/32	329325	4 X 3	5-17/32	329340A
2-1/2 X 2	3-7/32	329325A			

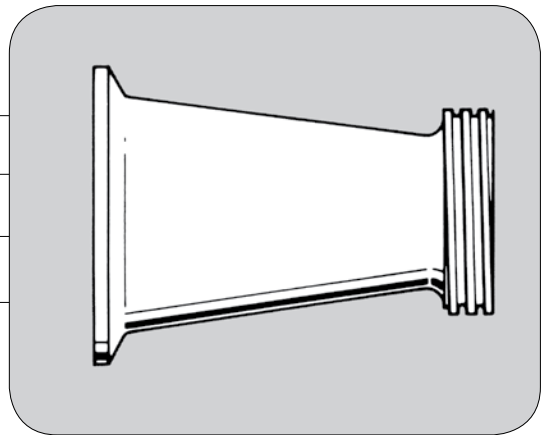

31PMP – REDUCING FERRULE-CONCENTRIC (3A)

SIZE (TUBE O.D.)	OVERALL LENGTH	STOCK NO.	SIZE (TUBE O.D.)	OVERALL LENGTH	STOCK NO.
*1-1/2 X 1	3-7/32	328615	3 X 2	5-13/32	328630
2 X 1	5-7/32	328620	3 X 2-1/2	3-13/32	328630A
2 X 1-1/2	3-7/32	328620A	4 X 2-1/2	7-23/32	328640
2-1/2 X 1-1/2	5-11/32	328625	4 X 3	5-23/32	328640A
2-1/2 X 2	3-11/32	328825A			

*HEX NUT INCLUDED (1-1/2" X 1")

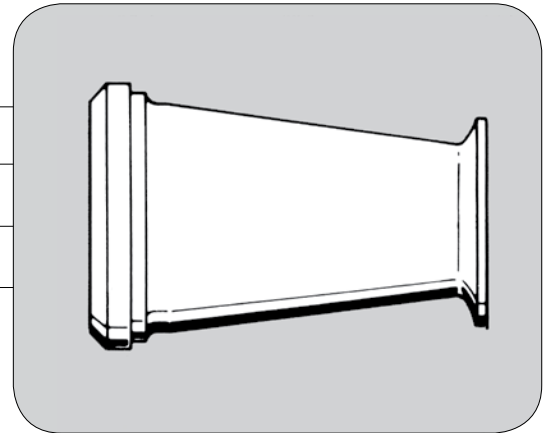

31MMP – ADAPTER - REDUCER - CONCENTRIC (3A)

SIZE (TUBE O.D.)	OVERALL LENGTH	STOCK NO.	SIZE (TUBE O.D.)	OVERALL LENGTH	STOCK NO.
1-1/2 X 1	4-1/8	328815	3 X 2	6-13/32	328830
2 X 1	6-1/8	328820	3 X 2-1/2	4-21/32	328830A
2 X 1-1/2	4-7/32	328820A	4 X 2-1/2	8-25/32	328840
2-1/2 X 1-1/2	6-7/32	328825	4 X 3	6-15/16	328840A
2-1/2 X 2	4-13/32	328825A			

HEX NUT INCLUDED

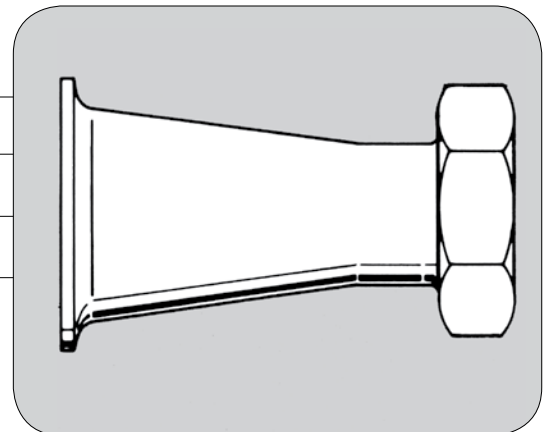

16AMP-SOLID END CAP (3A)

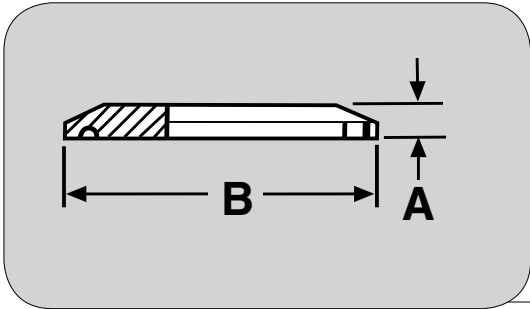

SIZE (TUBE O.D.)	A	B	STOCK NO.
1 & 1-1/2	.250	1.9843	329815
2	.250	2.516	329820
2-1/2	.250	3.047	329825
3	.250	3.579	329830
4	.312	4.682	329840

CLAMP GASKETS (1" O.D. TO 8" O.D.)(3A)



- O-RING**
 40MP-U BUNA N
 40MP-UW BUNA WHITE
 40MP-X SILICONE
 40MP-E E.P.D.M.
 40MP-G TEFLON
 40MP-SFY VITON



- FLANGED (TYPE 2)**
 40MPF-U BUNA N
 40MPF-X SILICONE
 40MPF-E E.P.D.M.
 40MPF-SFY VITON



- ENVELOPE (TYPE 3)**
 A40MP-GR TEFLON

 ALSO AVAILABLE
 BEVEL SEAT
 JOHN PERRY

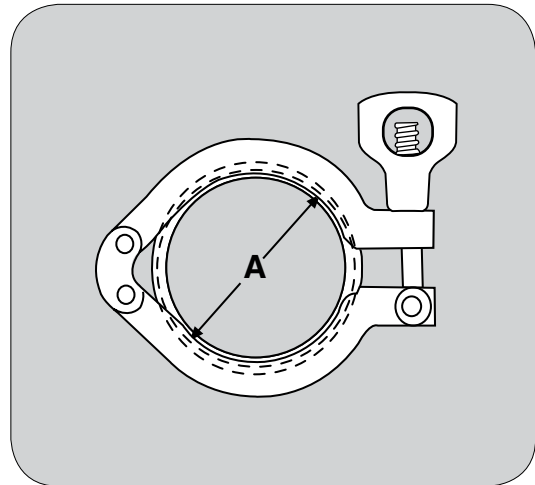

13MHHM-HEAVY DUTY CLAMP

SIZE RANGE: 1-1 1/2" TO 12" TUBE O.D.

SIZE (TUBE O.D.)	A	STOCK NO.
1-1 1/2	2.140	329915
2	2.610	329920
2 1/2	3.141	329925
3	3.673	329930
4	4.776	329940
8	8.695	329980
10	10.695	3299100
12	-	3299120

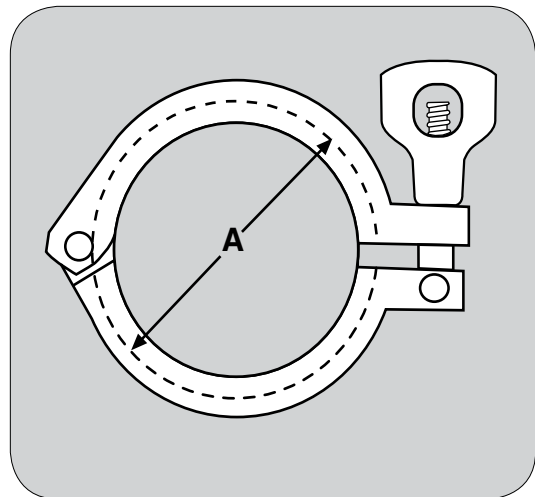

13LAH-HEAVY DUTY CLAMP

SIZE RANGE: 1/2" TO 8" TUBE O.D.

SIZE (TUBE O.D.)	A	STOCK NO.
1-1 1/2	2.140	3299915
2	2.610	3299920
2 1/2	3.141	3299925
3	3.673	3299930
4	4.776	3299940
6	6.695	3299960
8	8.700	3299980

13MHLA ADJUSTABLE CLAMP

SIZE RANGE: 1-1 1/2" TO 4" TUBE O.D.

SIZE (TUBE O.D.)	A	STOCK NO.
1-1 1/2	2.140	321415
2	2.610	321420
2 1/2	3.141	321425
3	3.673	321430
4	4.776	321440

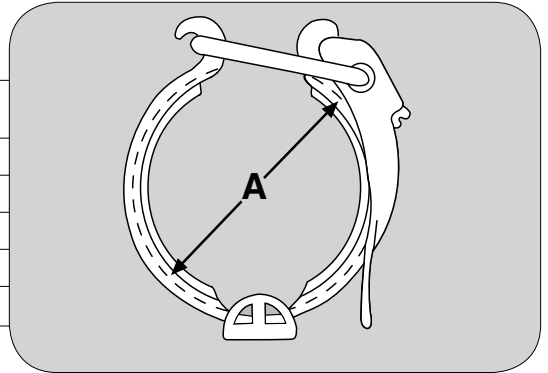

13MHP-HIGH PRESSURE CLAMP

SIZE RANGE: 1 1/2" TO 6" TUBE O.D.

SIZE (TUBE O.D.)	A	STOCK NO.
1-1 1/2	2.046	329915HP
2	2.578	329920HP
2 1/2	3.110	329925HP
3	3.640	329930HP
4	4.744	329940HP
6	6.632	329960HP

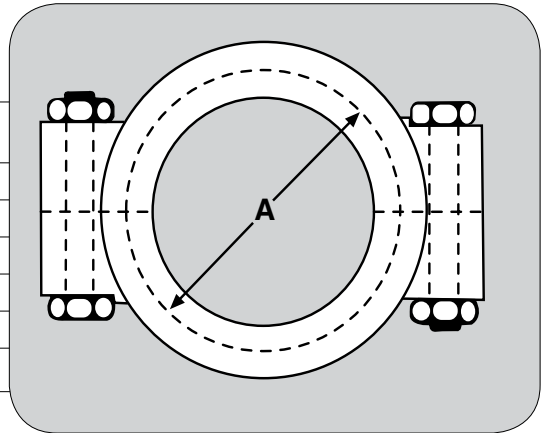

WITH ALUMINUM BRONZE NUTS

TOP LINE

PROCESS EQUIPMENT COMPANY

... the source for
all your product needs
in the process industries

Contact your Top Line Representative for Assistance

Office: P.O. Box 264 · Bradford, PA 16701

Plant: 21 Valley Hunt Drive · Lewis Run, PA 16738

800-458-6095

814-362-4626

Fax: 814-362-4453

PUMPS & STRAINERS- Centrifugal, Rotary Lobe, Filters and Strainers



VALVES - Manual, Actuated, Diaphragm



FITTINGS - Clamp, Sanitary Butt Weld, Bevel Seat, Tube OD Butt weld, Custom, Biopharm



TUBING, GAUGES, SIGHT GLASSES, BRAIDED HOSE



www.toplineonline.com