



Engineered For Lasting Performance™

INSTRUCTION AND MAINTENANCE MANUAL:

FS SERIES SHEAR BLENDER



Sanitary Mixing and Blending Equipment

DESCRIPTION

This manual contains installation, operation, assembly, disassembly and repair instructions for the Fristam FS series shear blender.

CAUTION: BEGIN ALL BLENDER MAINTENANCE OPERATIONS BY DISCONNECTING THE ENERGY SOURCE TO THE BLENDER. OBSERVE ALL LOCK OUT/TAG OUT PROCEDURES AS OUTLINES BY ANSI Z244.1-1982 AND OSHA 1910.147 TO PREVENT ACCIDENTAL START-UP AND INJURY.

TABLE OF CONTENTS

Technical Information.....	4-5
Preventative Maintenance	5
Single Seal Assembly drawing.....	6
Double Seal Assembly drawing	7
Exploded Assembly—FS 700-354	8-9
Seal Replacement	
Disassembly	10-11
Assembly	11-15
Shaft and/or Motor Replacement	
Disassembly	16
Assembly	17-18
Setting Rotor to Stator Gap	18
Installation/Piping.....	19-21
Warranty	22

TECHNICAL INFORMATION

SPECIFICATIONS

Maximum Inlet Pressure.....	150 PSI
Temperature Range.....	-40°F – 400°F

STANDARD MATERIALS OF CONSTRUCTION (NOTE: OTHER OPTIONS AVAILABLE)

Product Contact Components	AISI 316L Stainless Steel
Seal Components	
Single Rotating Seal.....	Chrome Oxide coated 316L Stainless Steel (gray/silver)
Stationary Seal	Carbon (black)
Double Rotating Seal (if installed).....	Ceramic (white)
Product Contact Surface Finish	32 in Ra
Flange Support.....	Cast Iron
Gaskets / O-rings	Viton
Cover O-ring.....	Buna
Motor	NEMA TEFC C-face, 3 Phase, 60 Hz, 208-230/460 VAC, 1750/3500 RPM

FRONT PULL-OUT SEAL OPTIONS

Single Internal Mechanical	
Single Internal Mechanical with Cascade	
Single Internal Mechanical with Double External Mechanical	
Recommended Seal Flush Pressure	5 PSI Maximum
Recommended Seal Flush Flow.....	1 –2 Gallons per Hour

SEAL SIZES

757 – Used on Models: 3520, 3530 & 3540	
Single Flange	
758 – Used on Model: 3550	
Double Flange	

RECOMMENDED TORQUE VALUES

Rotor Nut.....	40 ft-lbs
757 Housing Clamp Bolt.....	55 ft-lbs
758 Housing Bolts.....	50 ft-lbs
Stator Nuts	65 in-lbs
Motor Bolts	
56C – 140TC	20 ft-lbs
180TC – 280TC.....	55 ft-lbs
320TC – 360TC.....	110 ft-lbs
Shaft Collar Screw(s)	
1/4”-28	6 ft-lbs
5/16”-24	15 ft-lbs
3/8”-24	40 ft-lbs

ROTOR TO STATOR GAPS

All models	0.5 mm (0.020”)
------------------	-----------------

SHAFT RUN-OUT TOLERANCE

All models	0.05 mm (0.002”)
------------------	------------------

TOOLS FOR ASSEMBLY & DISASSEMBLY

10mm Socket.....	Stator nuts
9/16" Socket.....	56C – 140TC motor bolts
3/4" Socket.....	180TC – 280TC motor bolts, double flange housing bolts
.....	Single flange clamp bolt
3/4" Wrench.....	Single flange clamp bolt
15/16" Socket.....	Rotor nut, 320TC – 360TC motor bolts
3/16" Allen wrench socket.....	56C – 180TC shaft collars
1/4" Allen wrench socket.....	210TC – 250TC shaft collars
5/16" Allen wrench socket.....	280TC – 360TSC shaft collars
Ratchet.....	For loosening bolts
Torque wrench.....	For proper tightening
Adjustable pliers.....	For removing water pipes
Soft-faced hammer.....	For removing cover star nuts
3/8" diameter rod.....	For holding the shaft when tightening & loosening the impeller
Food grade lubricant.....	For lubricating o-rings and gaskets

MOTOR INFORMATION

Uses a NEMA TEFC C-face motor.

RECOMMENDED PREVENTIVE MAINTENANCE

RECOMMENDED SEAL MAINTENANCE

- Visually inspect mechanical seal daily for leakage.
- Replace mechanical seal annually under normal duty.
- Replace mechanical seal as often as required under heavy duty.

ELASTOMER INSPECTION

Inspect all elastomers when performing blender maintenance. We recommend replacing elastomers (o-rings and gaskets) during seal, blender shaft and/or motor replacement.

MOTOR MAINTENANCE

Consult motor manufacturer for recommended maintenance.

CLEAN IN PLACE (CIP)

The FS Shear Blender and FSI Shear Pump are CIP'able and will clean by means used to clean the adjacent piping.



SINGLE SEAL ASSEMBLY

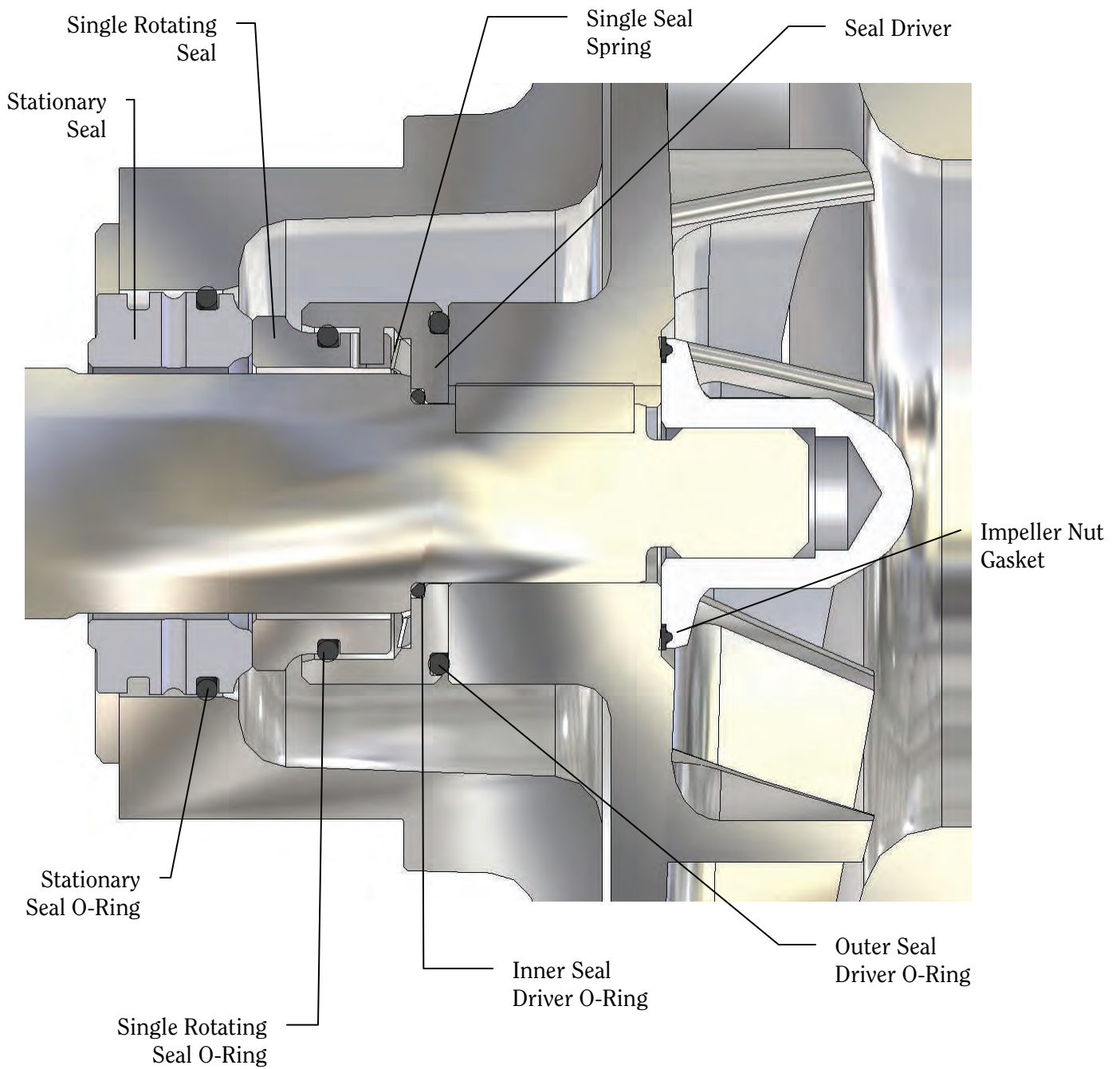

DOUBLE SEAL ASSEMBLY

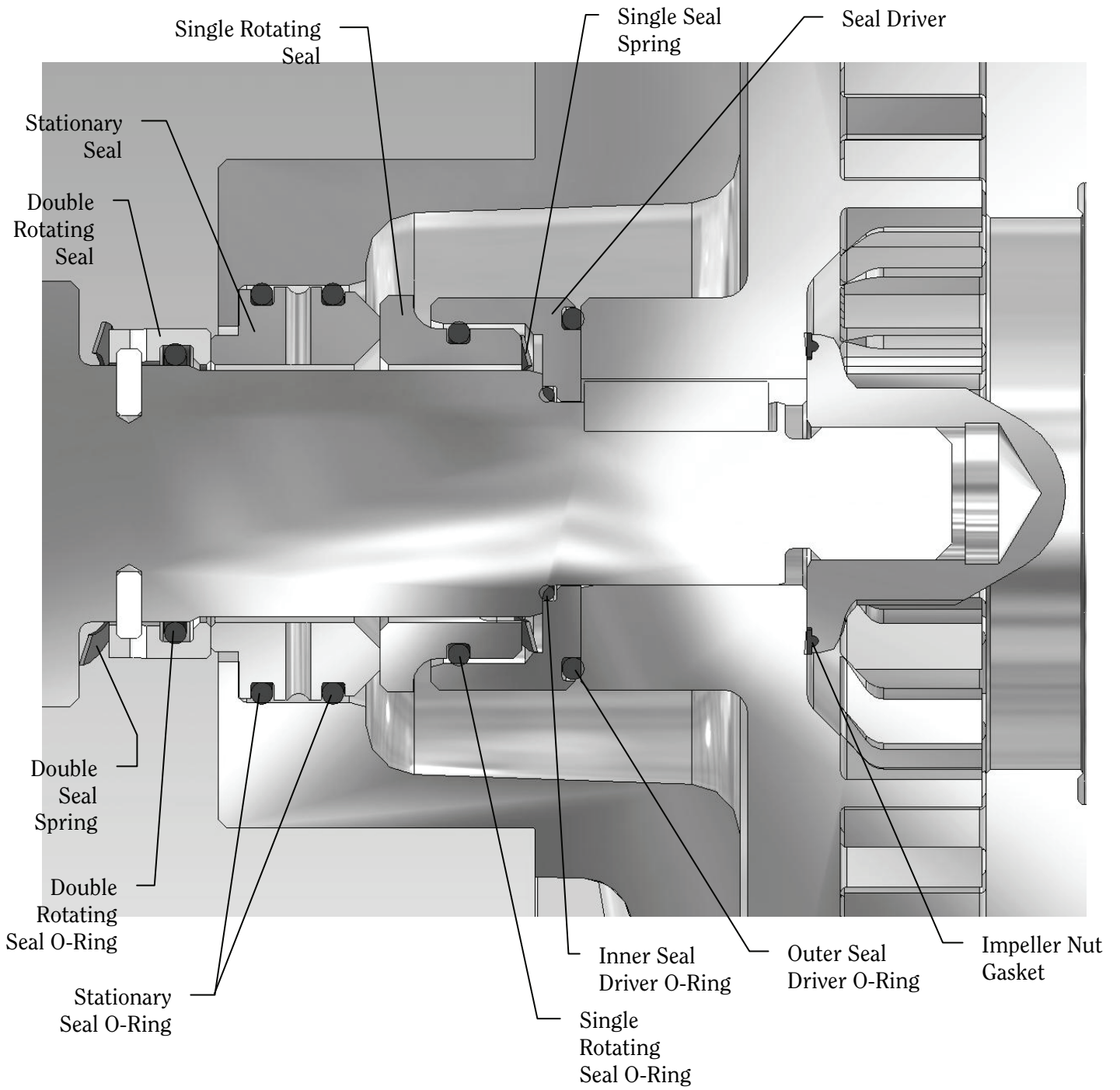

FS 3520, 3530 & 3540

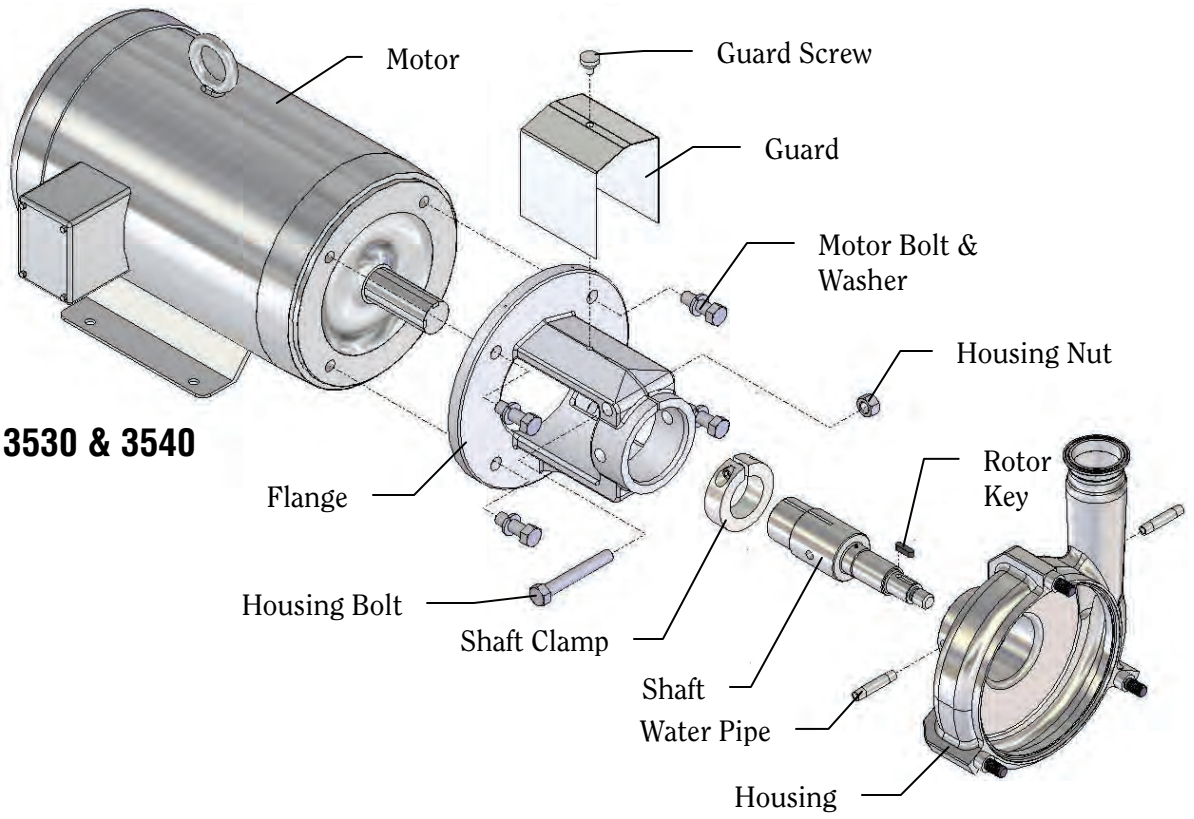

FS 3550

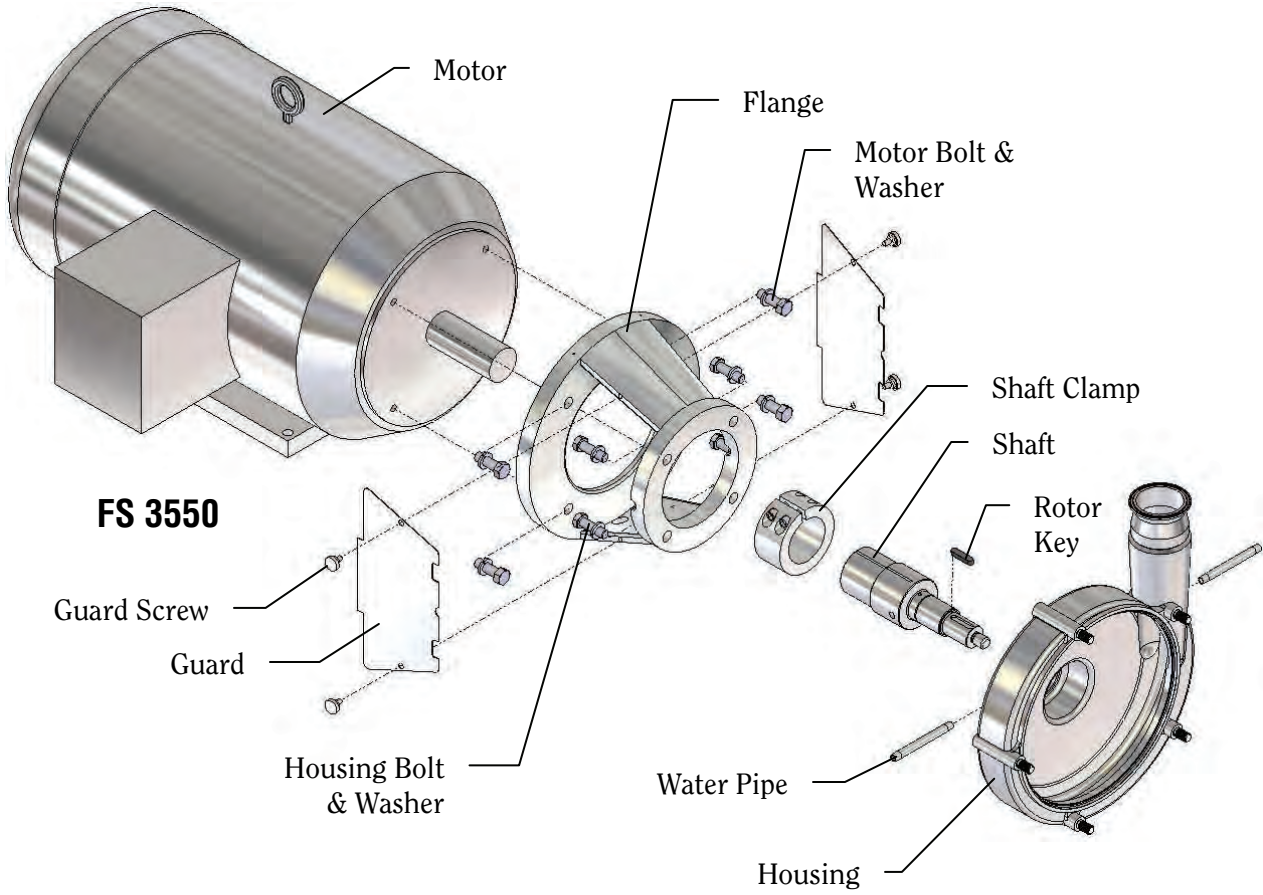

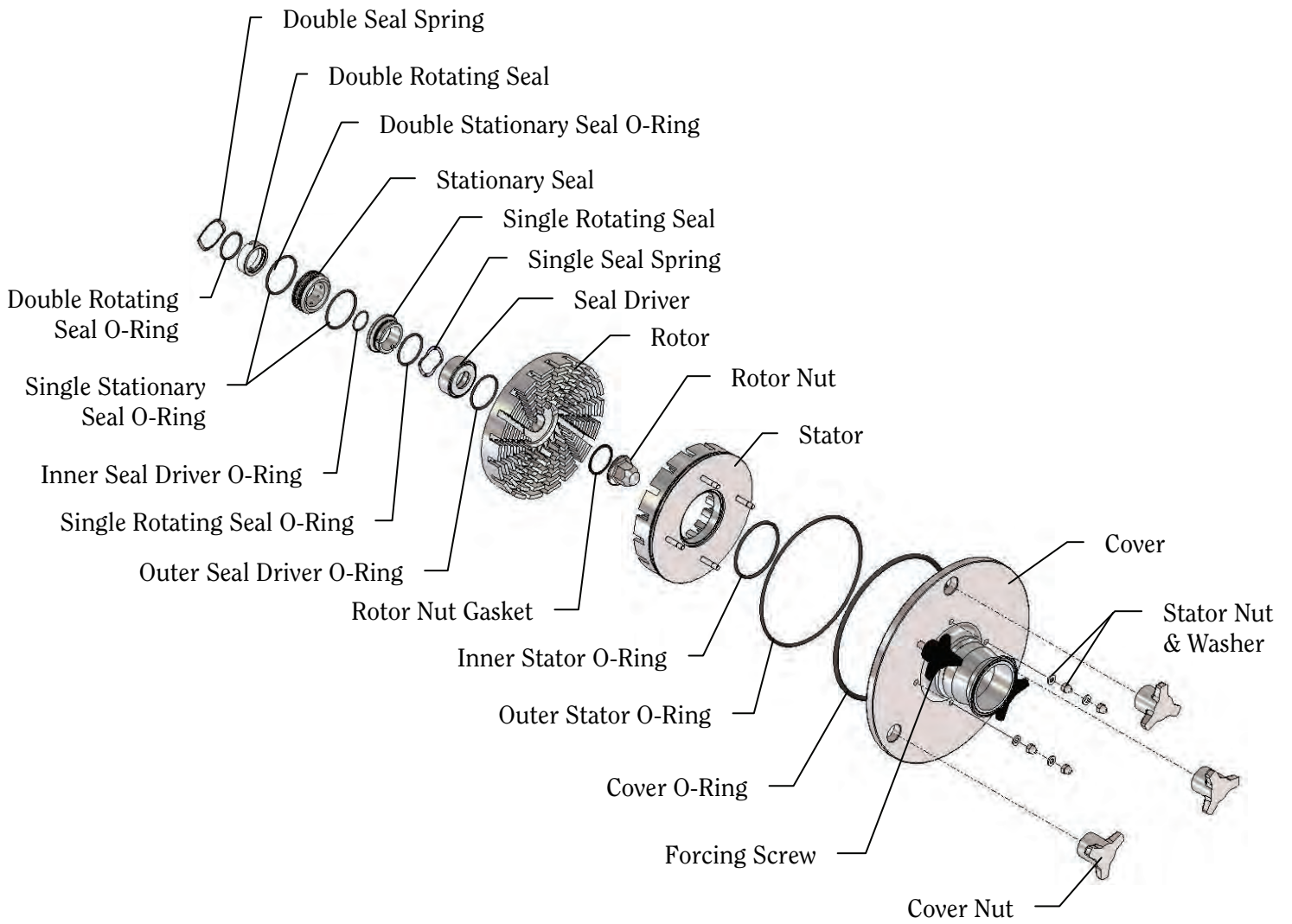

SEAL REPLACEMENT — DISASSEMBLY

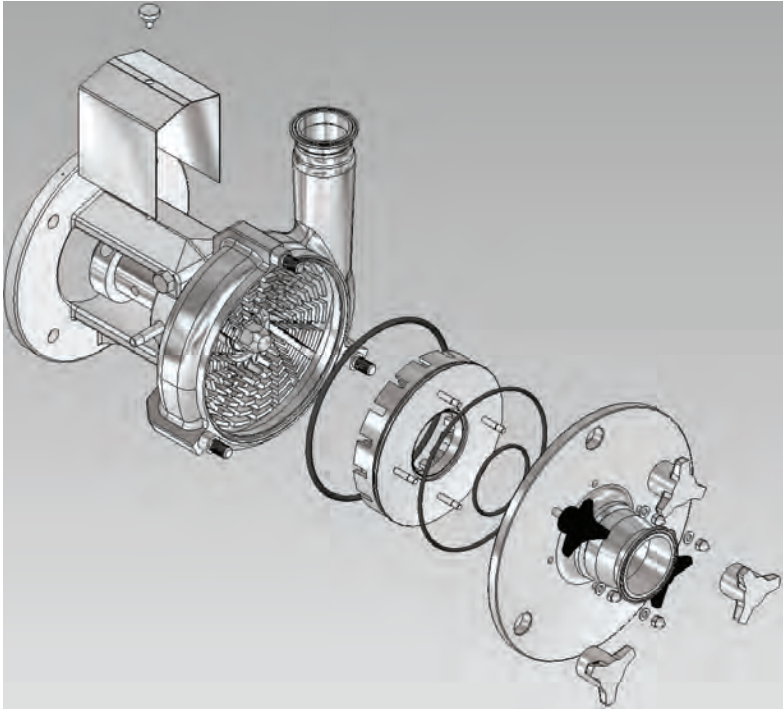

FIGURE 1

Remove the flange guard.

Remove the cover star nuts with soft-faced hammer.

Remove the cover/stator assembly. Remove the cover o-ring.

Remove the stator from the cover by turning the forcing screws clockwise to free the stator from the cover. Remove the stator o-rings.

FIGURE 2

Place a 3/8" rod or Phillips screwdriver in the shaft hole to prevent it from turning. Remove the rotor nut. Discard the rotor nut gasket.

Remove the rotor. You may need to insert two long rods or screwdrivers into the holes in the rotor to remove it.

Remove the rotor key.

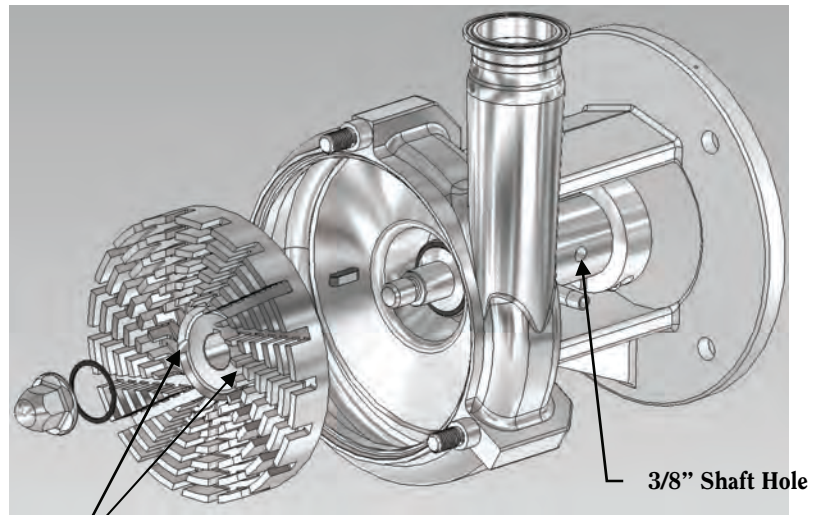

Holes in Rotor

3/8" Shaft Hole

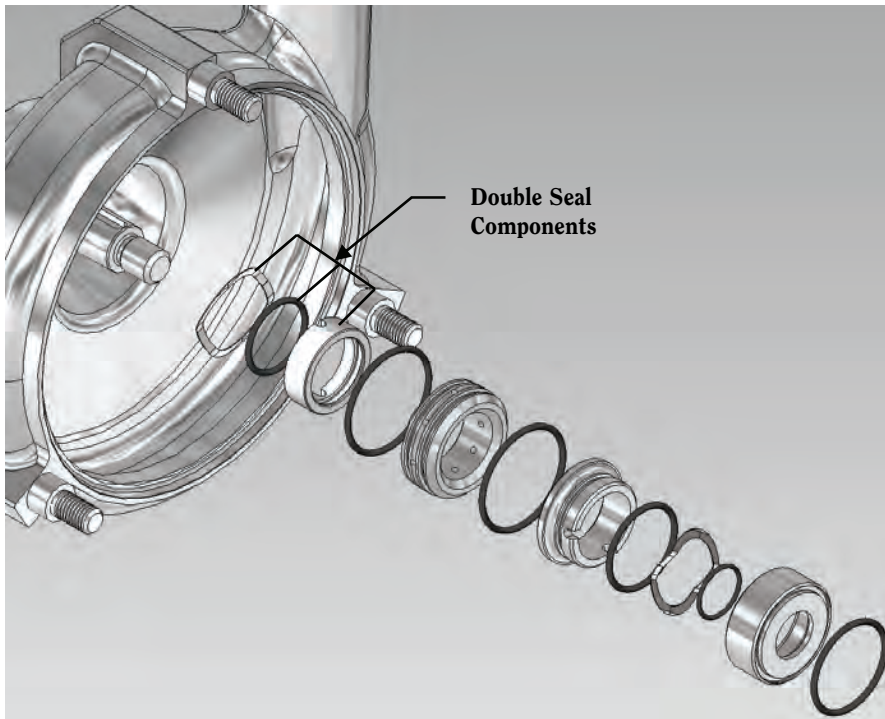

FIGURE 3

Remove the seal driver/rotating seal assembly. Discard rotating seal, o-rings and spring. **Do not discard the seal driver.**

Remove and discard the stationary seal and o-rings.

Double Seal Only: Remove and discard the double rotating seal, o-ring and double spring.

SEAL REPLACEMENT — ASSEMBLY

DOUBLE SEAL ONLY:

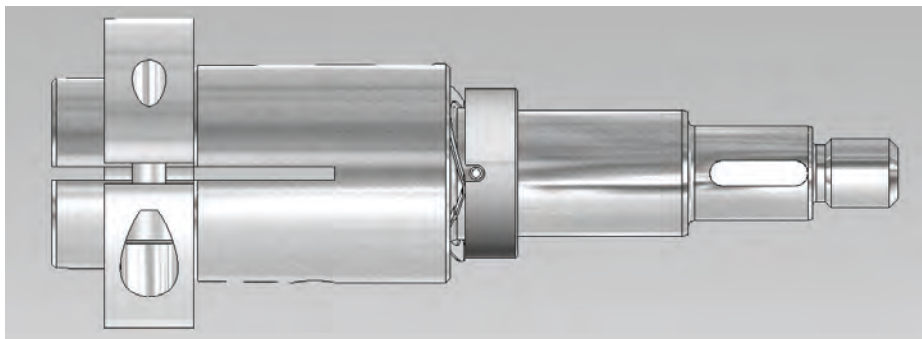

FIGURE 4

Install the spring behind the shaft pins. Place the o-ring into the double rotating seal and lubricate. Install the assembly onto the shaft making sure the slots align with the pins.

Note: The housing and flange removed from picture for clarity.

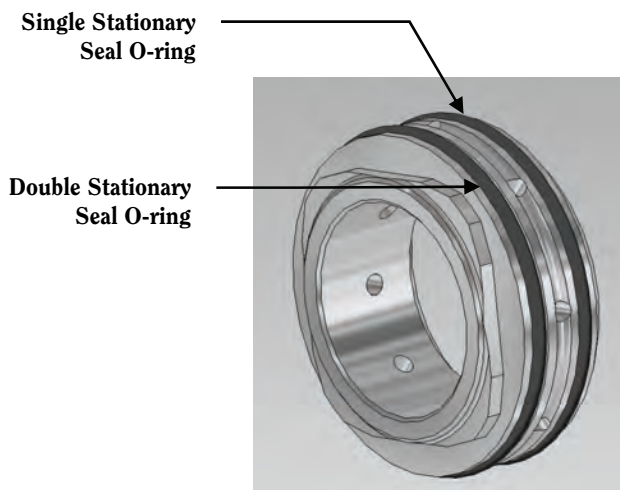

FIGURE 5

Single Seal:
Install single stationary seal o-ring and lubricate.

Double Seal: Install single and double stationary seal o-rings and lubricate.

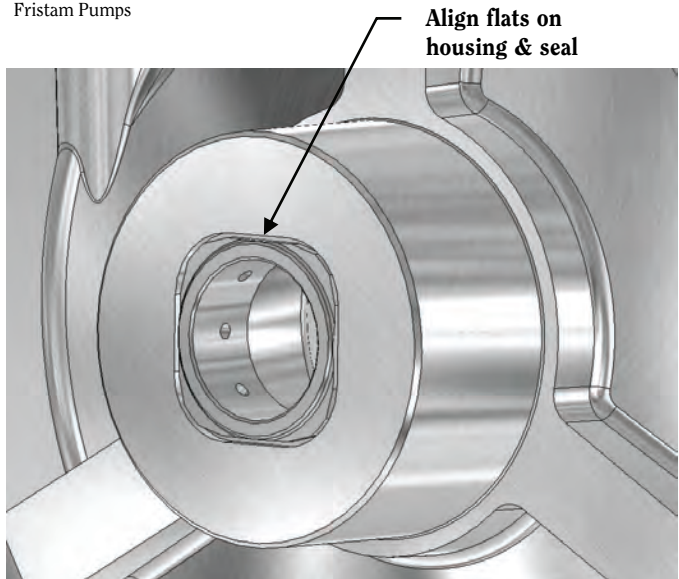

FIGURE 6

Install the stationary seal into the housing making sure to align the flats on the seal with the flats on the housing.

FIGURE 7

Install the spring behind the seal pins inside the seal driver.

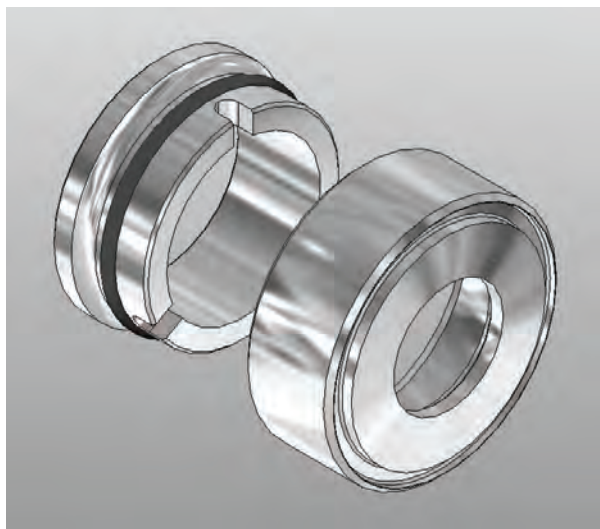
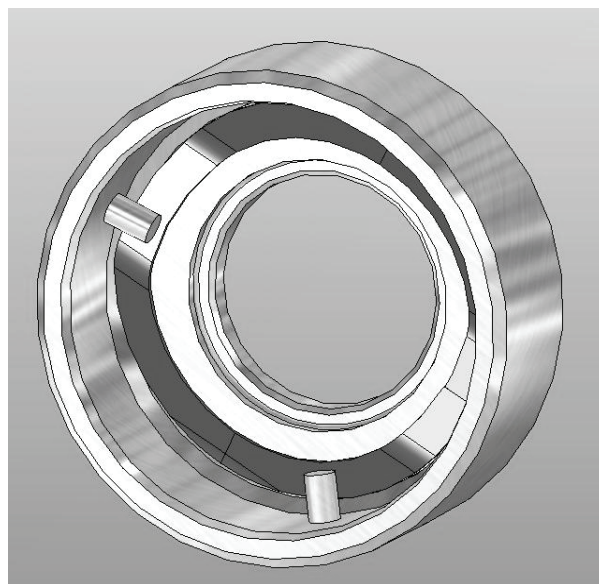

FIGURE 8

Install the single rotating seal o-ring and lubricate. Slide the seal driver onto the rotating seal making sure to align the pins inside the driver with the slots on the seal.

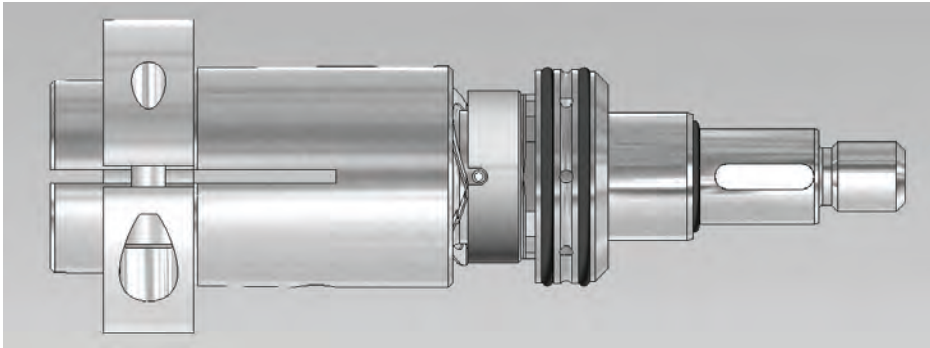

FIGURE 9

Slide the small rotating seal o-ring onto the shaft.

Note: The housing and flange removed from picture for clarity.

FIGURE 10

Slide the seal driver assembly onto the shaft.

Note: The housing and flange removed from picture for clarity.

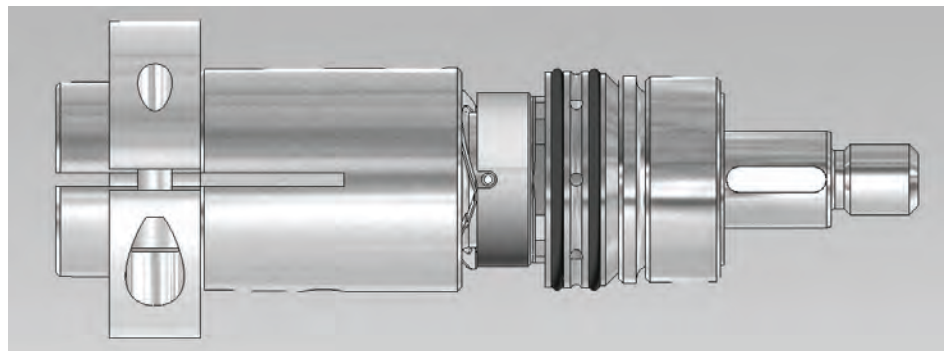

FIGURE 11

Install the impeller key and outer seal driver o-ring.

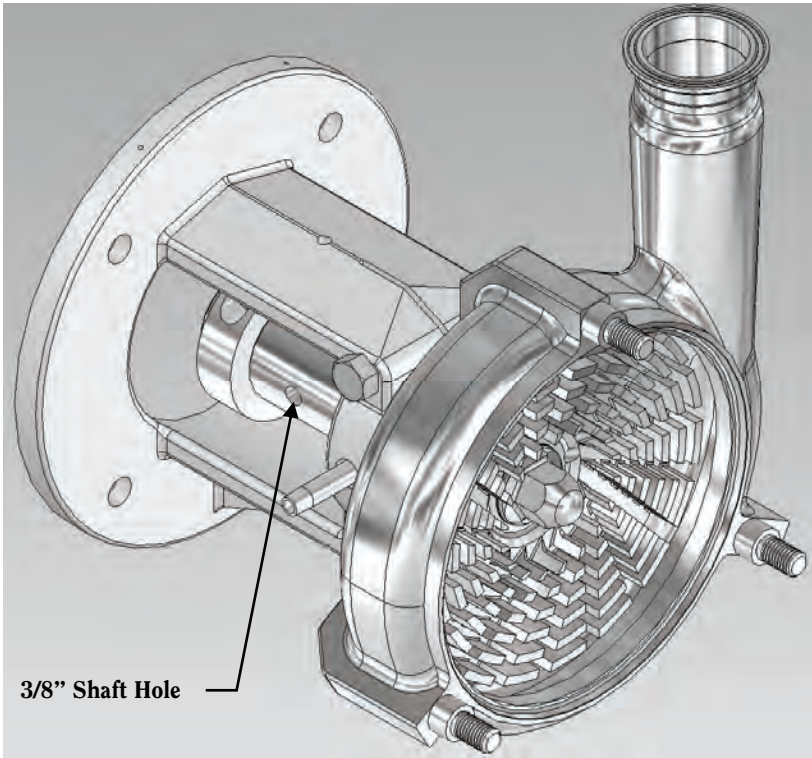

FIGURE 12

Install the rotor.

Lubricate the rotor nut gasket and place it onto the rotor nut.

Thread the rotor nut onto the shaft. Place a 3/8" rod or Phillips screwdriver in the shaft hole to prevent it from turning. Use a torque wrench to tighten the rotor nut.

FIGURE 13

Install the inner and outer stator o-rings.

Find the markings stamped on the stator and on the back of the cover. Install the stator onto the cover, making sure to align the markings so they are face-to-face when assembled together. Tighten the stator nuts with a torque wrench.

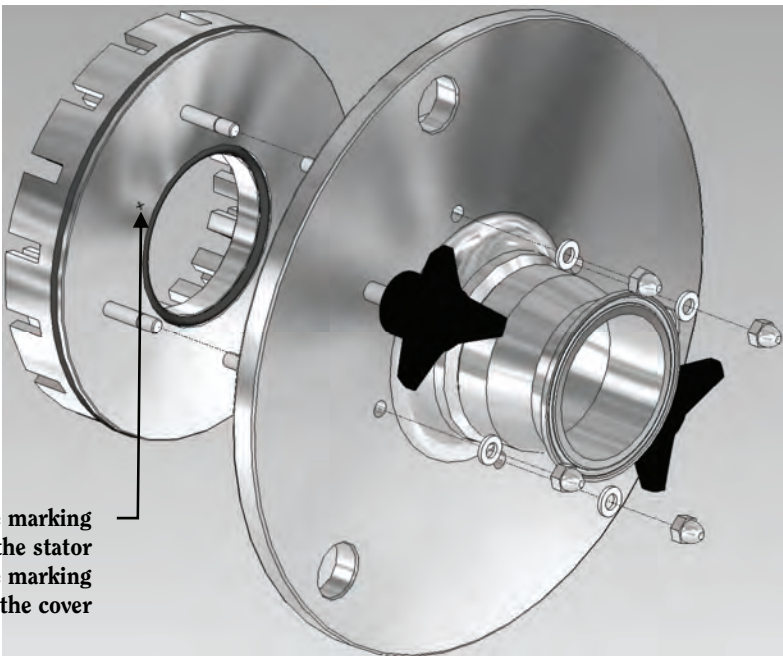

Align the marking on the stator with the marking on the cover

FIGURE 14

Install the cover o-ring.

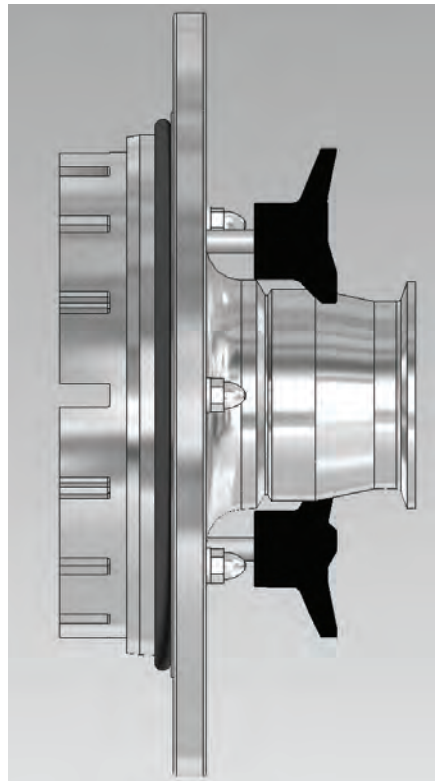

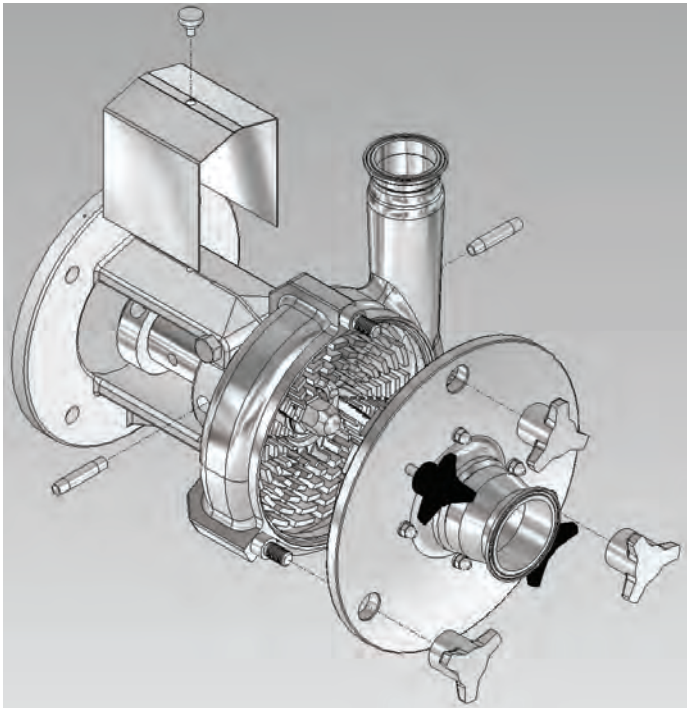

FIGURE 15

Install the cover/stator assembly onto the housing.

Install the cover star nuts and tighten with a soft-faced hammer.

Rotate the shaft to verify that the rotor turns freely.

Install the guard.

Install the water pipe(s) if necessary.

SHAFT AND/OR MOTOR REPLACEMENT — DISASSEMBLY

Disassemble blender as described in Figure 1-3, page 10-11.

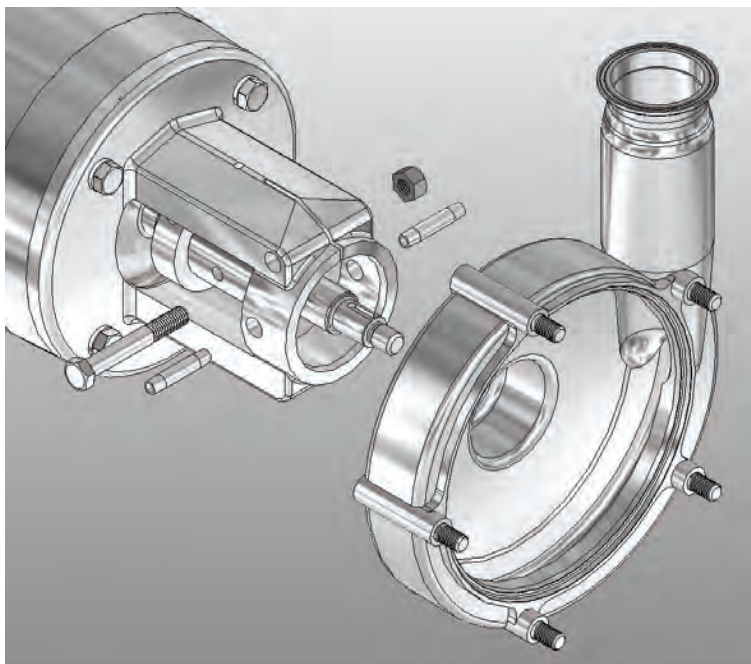

FIGURE 16 (3520-3540 MODELS ONLY)

Double Seal and Water Cascade Only: Remove the water pipe(s).

Loosen the clamping bolt and nut. Remove the housing.

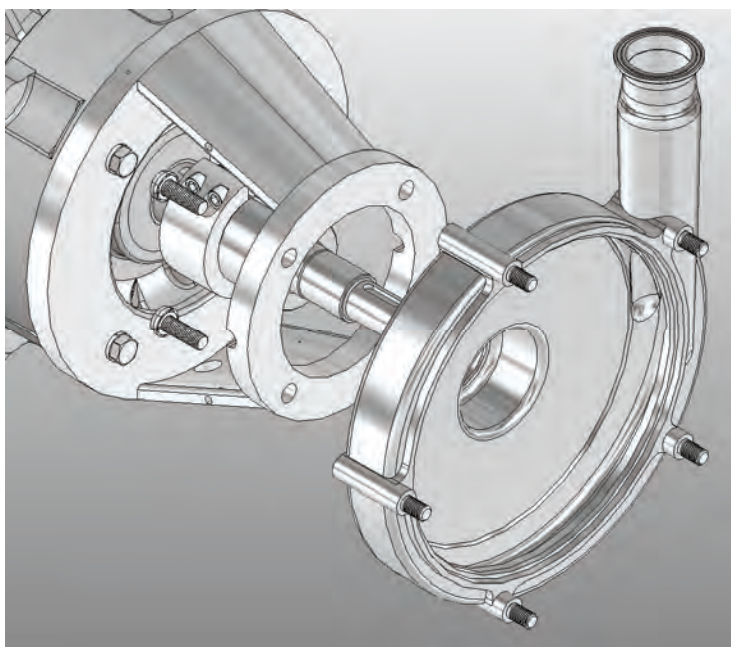

FIGURE 16 (3550 MODEL ONLY)

Double Seal and Water Cascade Only: Remove the water pipe(s).

Remove the housing bolts and washers. Remove the housing.

FIGURE 17

Loosen the shaft clamp cap screw(s). Remove blender shaft.

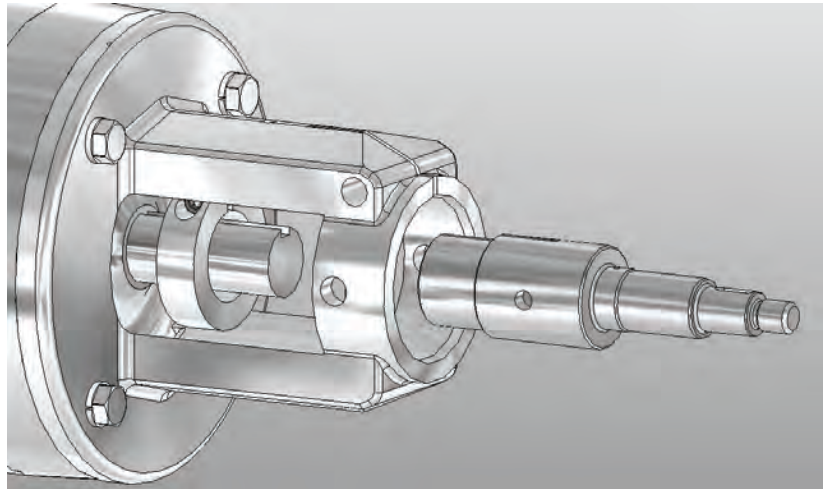

SHAFT AND/OR MOTOR REPLACEMENT — ASSEMBLY

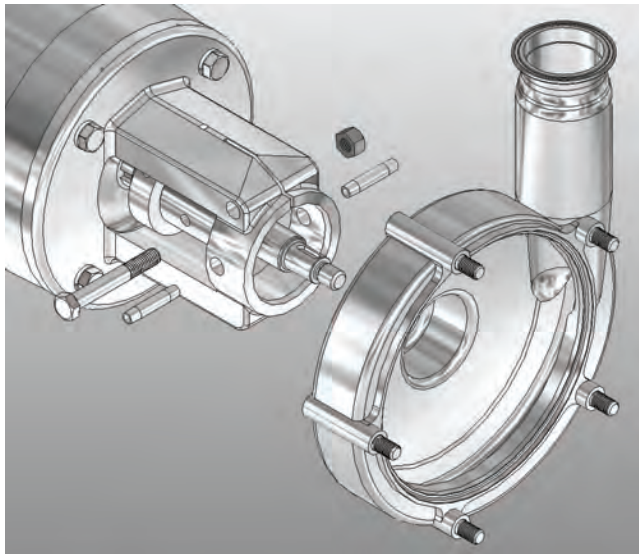

FIGURE 18 (3520-3540 MODELS ONLY)

Install the shaft. **Do not tighten the shaft clamp.**

Install the housing. Rotate the inlet to align it with the piping.

Tighten the clamping bolt with a torque wrench.

FIGURE 18 (3550 MODEL ONLY)

Install the shaft. **Do not tighten the shaft clamp.**

Install the housing. Rotate the inlet to align it with the piping and align bolt holes.

Install the housing lockwashers and bolts. Tighten the housing bolts with a torque wrench.

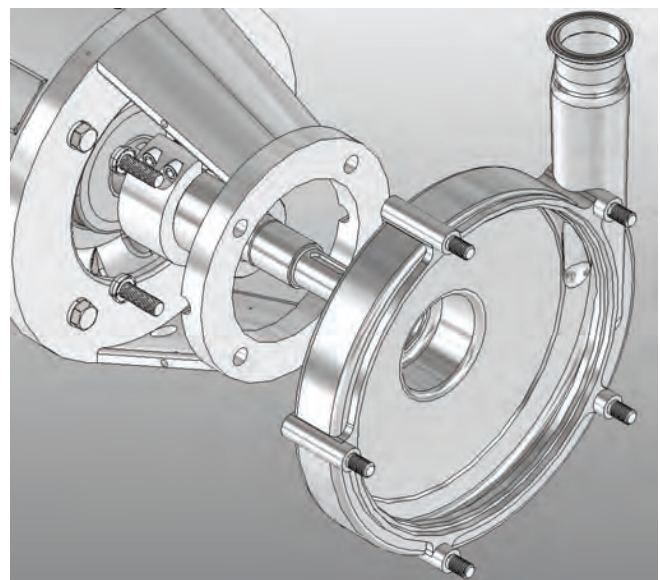

SETTING THE ROTOR TO STATOR GAP

If you have removed the pump shaft from the motor shaft for any reason (such as replacing the shaft or motor), you must re-set the gap. Assemble the blender as described in Figures 4-12, page 11-14.

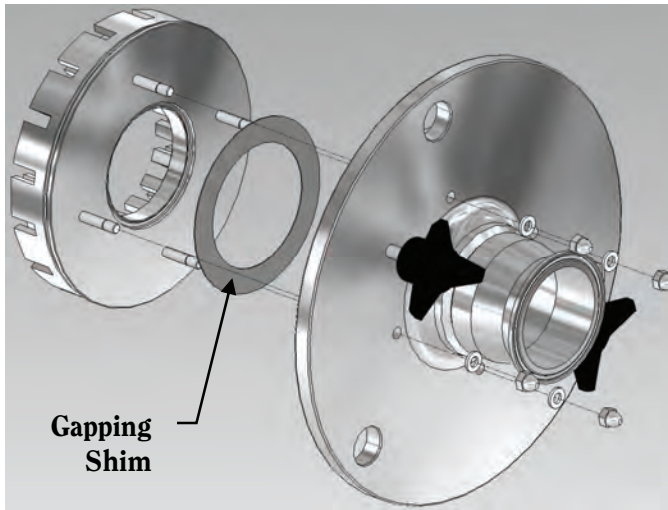

FIGURE 19

Place a 0.5mm gapping shim in between the stator and cover and install the stator lockwashers and nuts. The o-rings do not need to be installed on the stator.

FIGURE 20 & 21

Install the cover/stator assembly onto the housing.

Install the cover star nuts and tighten with a soft-faced hammer.

Push the shaft forward until the rotor contacts the stator. Make sure to align the slot in the shaft with the slot in the shaft clamp. Also align the keyway in the motor shaft with the hole in the blender shaft. Tighten the shaft clamp bolt with a torque wrench.

Remove the cover and disassemble the stator. Remove the gapping shim.

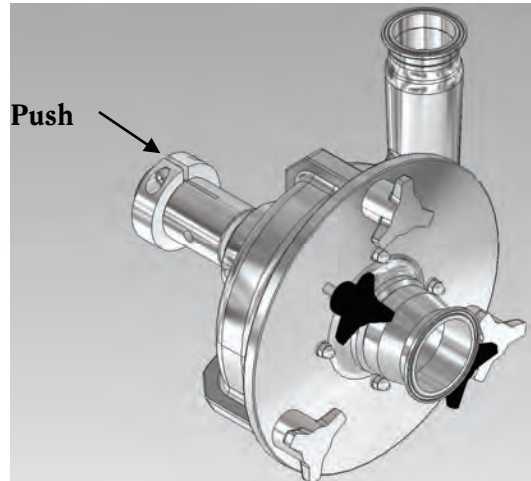

Note: The motor and flange removed from picture for clarity.

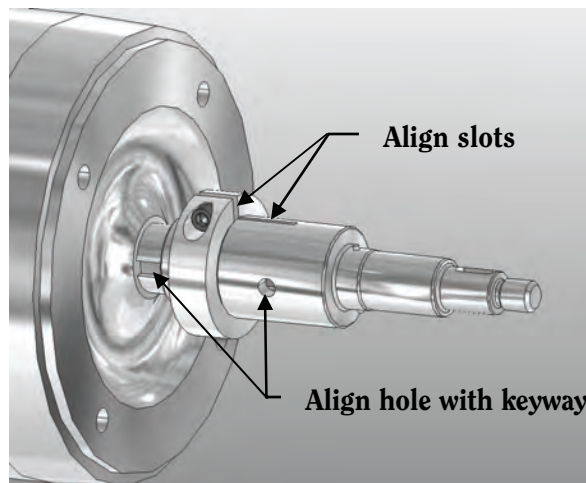

Note: The flange and blender head removed from picture for clarity.

SETTING THE SHAFT ALIGNMENT

If you have removed the pump shaft from the motor shaft for any reason (such as replacing the shaft or motor), you must check the shaft alignment.

Remove the rotor, as described in Figure 2, page 10.

Remove the housing, as described in Figure 16, page 16.

Using a dial indicator or similar device, measure the shaft alignment. The TIR (Total Indicated Run-out) of the shaft must be within .05mm (.002in).

To adjust run-out, tap the end of the shaft at its high point with a soft-faced hammer until it is within the tolerance.

Re-install the housing.

Continue the installation process as described in Figures 12-15, page 14-15.

INSTALLATION

UNPACKING

Check the contents and all wrapping when unpacking the blender. Inspect the blender carefully for any damage that may have occurred during shipping. Immediately report any damage to the carrier. Remove the shaft guard and rotate the blender shaft by hand to make sure the impeller rotates freely. Keep the protective caps over the blender inlet and outlet in place until you are ready to install the blender.

INSTALLING

Prior to actually installing the blender, ensure that:

- The blender will be readily accessible for maintenance, inspection and cleaning.
- Adequate ventilation is provided for motor cooling.
- The drive and motor type is suitable for the environment where it is to be operated. Blenders intended for use in hazardous environments (i.e. explosive, corrosive, etc.) must use a motor and drive with the appropriate enclosure characteristics. Failure to use an appropriate motor type may result in serious damage and/or injury.

PIPING GUIDELINES

This section describes good piping practices to obtain maximum efficiency and service life from your blender.

Maximum performance and trouble-free operation require adherence to good piping practices.

- Ensuring proper piping support and alignment at both the suction inlet and discharge outlet can help prevent serious damage to the blender housing (**Figure 22**).
- Avoid abrupt transitions in the piping system (**Figure 23**).

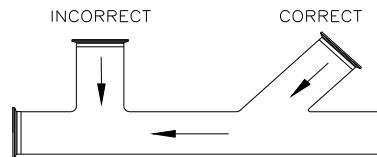

Figure 23

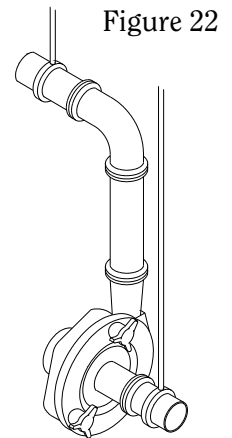

Figure 22

- Avoid throttling valves in the suction piping.
- Keep suction lines as short and direct as possible.
- Ensure that the NPSH available in the system is greater than NPSH required by the blender.
- Avoid sump areas where sediments may collect (**Figure 24**).

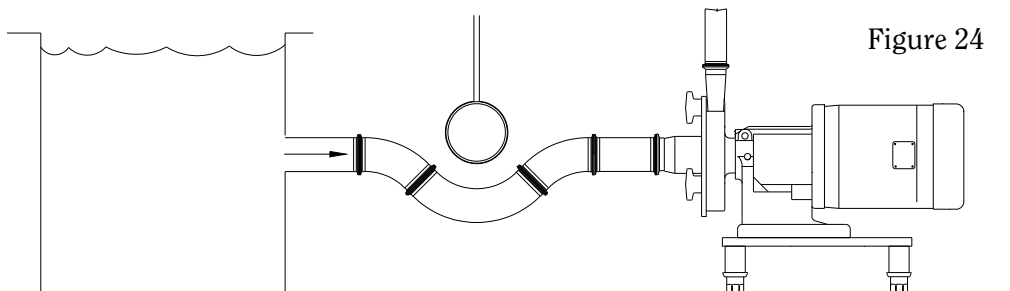
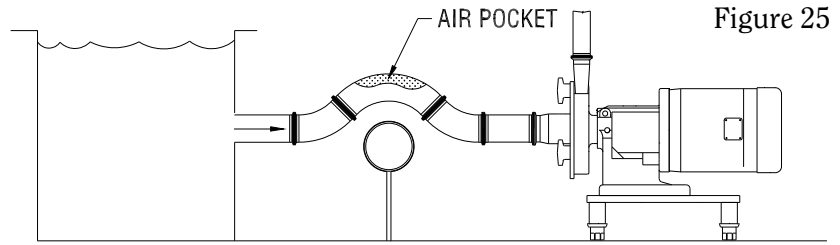
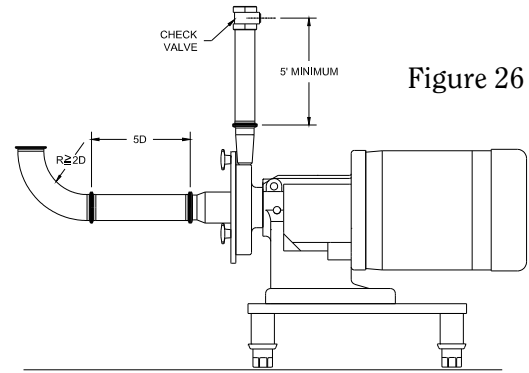

Figure 24

- Avoid the formation of air pockets in the piping (**Figure 25**).
- Avoid abrupt closure of shut-off valves, this may cause hydraulic shock which can cause severe damage to the blender and system.



- Avoid elbows in the suction line if possible. When necessary they should be located 5 pipe diameters away from the blender inlet, and have a bend radius greater than 2 pipe diameters (**Figure 26**).
- Check valves in discharge line should be a minimum of 5 ft. away from the blender outlet (**Figure 26**).



INSTALLATION OF WATER FLUSH FOR DOUBLE MECHANICAL SEAL

Set up the water flush for the double mechanical seal as shown (**Figure 27**). **Use only between 1-2 gallons per hour of water at a maximum pressure of 5 PSI.** Excessive flow of water through the seal increases the pressure inside the seal. **Note:** maximum pressure inside the seal is 5 PSI. **Excessive flow/pressure through the seal flush will cause excessive wear and shorten seal life.**

Pipe the exit side of the water flush with 2-5 feet physical height of tubing. This ensures that some water is always in the center seal and the seal never runs dry.

It is possible to inject steam through the center seal (within the pressure requirements). We do not recommend using steam alone for the cooling/lubricating of the seal.

It is desirable to have the flush water on the outlet side visible. This allows an easy check to see that the flush water is on and also if the seal is functioning properly. In a malfunctioning seal the flush water will disappear, become discolored, or show an unusual increase in flow. If these conditions exist, check the seal and replace if necessary.

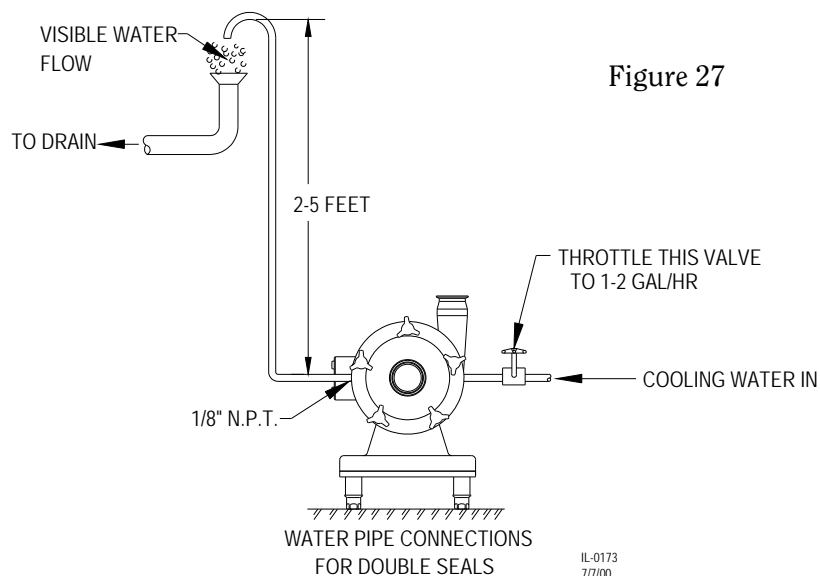

Figure 27

INSTALLATION OF WATER CASCADE

The water cascade (if supplied) is piped through the hub of the housing and into the stationary seal. Since there is no rear seal, the flush water will exit through the rear of the seal area (**Figure 28**).

Not all FS blenders require a water cascade on the seal.

Use about 1-2 gallons per hour of water at a maximum pressure inside the seal of 5 psi.

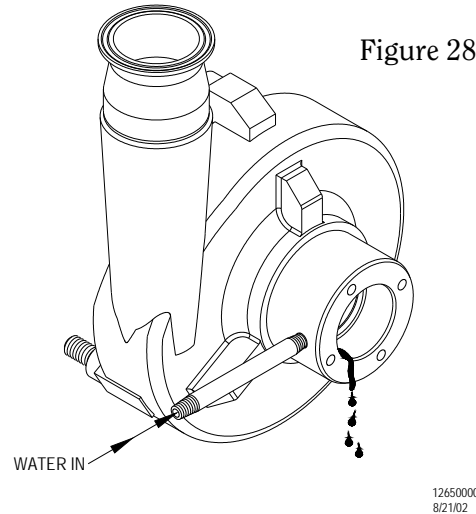

ELECTRICAL INSTALLATION

We use standard duty TEFC motors unless otherwise specified. Many motor options are available: washdown, flameproof, explosion proof, hostile duty or chemical duty.

The motor selected should meet the requirements of the specified operating conditions. A change in conditions (for example, higher viscosity, higher specific gravity, lower head losses) can overload the motor. When changing operating conditions or whenever there is any doubt, please contact Fristam Pumps for technical assistance.

Have an electrician connect the motor using sound electrical practices. Provide adequate protection. Blenders fitted with mechanical seals must not run dry, not even momentarily. **Determine the direction of rotation by watching the motor fan, which must turn clockwise.**

BLENDER OPERATIONS

START-UP INSTRUCTIONS

- Remove any foreign matter that may have entered the blender.
- Do not use the blender to flush the system!
- Check blender for proper rotation as indicated on the blender. **Proper motor direction is clockwise when looking at the fan end of the motor.** (NOTE: When checking the direction of rotation, the blender must be full of liquid.)
- Never run the blender dry, even momentarily. Seal damage can result.

SHUT-DOWN INSTRUCTIONS

- Shut off the power supply to the blender.
- Close the shut-off valves in the suction and discharge piping.
- Drain and clean the blender.
- Protect the blender against dust, heat, moisture and impact damage.

NOTICE OF TERMS, WARRANTY PROVISIONS INCLUDING DISCLAIMERS, CLAIMS AND LIMITATION OF LIABILITY

Prices and all terms and conditions of sale are established in current price sheets and are subject to change without notice. All orders are subject to acceptance by Fristam Pumps USA, Limited Partnership.

Each Fristam Pumps item is warranted to be free from manufacturing defects for a period of one (1) year from the date of shipment, providing it has been used as recommended and in accordance with recognized piping practice, and providing it has not been worn out due to severe service, such as encountered under extremely corrosive or abrasive conditions.

This warranty is expressly in lieu of any other warranties expressed or implied, including but not limited to, any implied warranty of merchantability or fitness for particular purpose. All other warranties whatsoever, expressed or implied by law or otherwise, are hereby excluded.

All claims must be in writing and must be mailed or delivered by purchaser within thirty (30) days after purchaser learns of the facts upon which such claim is based. Any claim not made in writing and within the time period specified above shall be deemed waived.

Purchaser's sole and exclusive remedy and Fristam Pumps maximum liability for claims arising hereunder or for negligence for any and all losses and damages resulting from any cause shall be either the repair or replacement of defective items or, at Fristam Pumps' option, the refund of the purchase price for such items. In no event, including in the case of a claim for negligence, shall Fristam Pumps be liable for incidental or consequential damages, including loss of profits.

No person, including any representative employee or agent of Fristam Pumps is authorized to assume on behalf of Fristam Pumps any liability or responsibility in addition to or different from that described in this provision. Any and all representations, promises, warranties or statements that are in addition to or different from the terms of this provision are of no force or effect.

If any provision of this Notice is held to be invalid, such provision shall be severed and the remaining provisions shall continue to be in force.



© Copyright 2010 - Fristam Pumps USA
Drawing # 1250000022 Rev— Updated 7/6/10
Part # 1050000216
Visit www.fristam.com/usa for a current list of literature.

2410 Parview Road • Middleton, WI 53562-2524
1-800-841-5001 • 608-831-5001
Website: www.fristam.com/usa
Email: fristam@fristampumps.com