



Engineered For Lasting Performance™

INSTRUCTION AND MAINTENANCE MANUAL:

FL II Series Pumps (Models: 15, 58, 75, 100 & 130)



SANITARY POSITIVE DISPLACEMENT PUMPS

DESCRIPTION

This manual contains installation, operation, assembly, disassembly and repair instructions for the Fristam FLII 15, 58, 75, 100 & 130 models rotary pump.

Fristam FLII Series bi-wing rotor pumps are positive-displacement pumps with non-contact rotors.

Fristam's FL II Series bi-wing rotor design combines mechanical simplicity with pumping efficiency. The pump's bi-wing rotor provides easy maintenance, cleanability, gentle product handling and dependability. With nine pump models and a full range of options, you can match your process needs precisely.

The FL II Series pump is available with any connection type desired and may be mounted with the inlet/outlet connections in a horizontal or vertical orientation. The pump should be coupled to a motor/drive assembly properly specified to give the desired performance for the required application.



DANGER:

BEGIN ALL PUMP MAINTENANCE OPERATIONS BY DISCONNECTING THE ENERGY SOURCE TO THE PUMP. OBSERVE ALL LOCK OUT/TAG OUT PROCEDURES AS OUTLINED BY ANSI Z244.1-1982 AND OSHA 1910.147 TO PREVENT ACCIDENTAL START-UP AND INJURY.

TABLE OF CONTENTS

DESCRIPTION	2
TABLE OF CONTENTS	3
TECHNICAL INFORMATION	4
INSTALLATION	7
RECOMMENDED PREVENTIVE MAINTENANCE	9
SEAL REPLACEMENT	10
SINGLE SEAL ASSEMBLY DRAWING	11
DOUBLE SEAL ASSEMBLY DRAWINGS	12
PUMP END DISASSEMBLY	13
ADDITIONAL DISASSEMBLY FOR DOUBLE SEAL ONLY	14
SEAL ASSEMBLY - DOUBLE SEAL	15
SEAL ASSEMBLY	15
PUMP END ASSEMBLY	16
SHAFT AND/OR BEARING REPLACEMENT	18
GEARBOX DISASSEMBLY	18
GEARBOX ASSEMBLY	19
FL II 15 AND 58 (SINGLE SEAL)	21
FL II 15 PART NUMBER LIST	21
PUMP ASSEMBLY DRAWING	22
FL II 58S PART NUMBER LIST	24
FL II 58L PART NUMBER LIST	25
FL II 75 AND 100	26
PUMP ASSEMBLY DRAWING	26
FL II 75S PART NUMBER LIST	28
FL II 75L PART NUMBER LIST	29
FL II 100S PART NUMBER LIST	30
FL II 100L PART NUMBER LIST	31
FL II 130 32	
PUMP ASSEMBLY DRAWING	32
FL II 130S PART NUMBER LIST	34
FL II 130L PART NUMBER LIST	35
TROUBLESHOOTING	36
NOTICE OF TERMS, WARRANTY PROVISIONS INCLUDING DISCLAIMERS, CLAIMS AND LIMITATION OF LIABILITY	37
PUMP MAINTENANCE RECORD	38

TECHNICAL INFORMATION

SPECIFICATIONS

Maximum Differential Pressure	FL II 15 - 145 PSI
.....	FL II 58S - 130 PSI
.....	FL II 58L - 115 PSI
.....	FL II 75S, 100S & 130S - 170 PSI
.....	FL II 75L, 100L & 130L - 120 PSI
Maximum Inlet Pressure	100 PSI
Temperature Range	up to 350 °F
(For temperatures over 200°F contact your local distributor or Fristam for special pump requirements).	

MATERIALS OF CONSTRUCTION

Primary Product Contact Components	AISI 316L
Cover Gasket	Viton (standard)
Also Available in	EPDM
Surface Finish for Product Contact Surfaces	32 Ra (standard)

SHAFT SEALS

Seal Types.....	Single & Double Mechanical
Recommended Seal Flush Water Pressure (double seal)	1-2 PSI (60 PSI maximum)
Recommended Seal Flush Water Flow Rate (double seal)	3-12 gph
Stationary Seal Ring Material	Carbon
Also Available in	Silicon carbide
Rotating Seal Ring Material	Chrome oxide coated stainless steel
Also Available in	Silicon carbide
O-ring Material	Viton (standard)
Also Available in	EPDM and other options available

LUBRICATION

Oil Grade: FL II 15.....	ISO Synthetic 220
FL II 58 - 130.....	ISO EP 220
Oil Capacity - Horizontal	
FL II 15	0.16 liters (0.04 US gallons)
FL II 5826 liters (.07 US gallons)
FL II 7545 liters (.12 US gallons)
FL II 100	1.17 liters (.31 US gallons)
FL II 13095 liters (.25 US gallons)

Oil Capacity - Vertical - NOTE: if foaming occurs, please use SAE 50 oil with no foaming characteristics.

FL II 15	0.16 liters (0.04 US gallons)
FL II 5826 liters (.07 US gallons)
FL II 7534 liters (.09 US gallons)
FL II 10095 liters (.25 US gallons)
FL II 13072 liters (.19 US gallons)

TABLE A1: WOODS SURE-FLEX COUPLING ALIGNMENT

Sleeve Size	Type E			Type H		
	Parallel A	Angular Y max. - Y min.	Y*	Parallel A	Angular Y max. - Y min.	Y*
6	.015	.070	2.375	.010	.016	2.375
7	.020	.081	2.563	.012	.020	2.563
8	.020	.094	2.938	.015	.025	2.938
9	.025	.109	3.500	.017	.028	3.500
10	.025	.128	4.063	.020	.032	4.063
11	.032	.151	4.875	.022	.037	4.875
12	.032	.175	5.688	.025	.042	5.688
13	.040	.195	6.688	.030	.050	6.625
14	.045	.242	7.750	.035	.060	7.750

Dimensions are in inches.

*The "Y" dimension is shown for reference.

TABLE A2: RECOMMENDED TORQUE VALUES:

	Cover/housing nuts	Rotor nut (standard)	Rotor Nut (flat cover)	Bearing Lock Nut rolling torque
15	5 ft-lbs.	n/a	5 ft-lbs. (M8)	
58L & S	15 ft-lbs.	50 ft-lbs.	5 ft-lbs. (M8)	3 in-lbs.
75L & S	30 ft-lbs.	80 ft-lbs.	10 ft-lbs. (M10)	4 in-lbs.
100L & S	45 ft-lbs.	130 ft-lbs.	n/a	9 in-lbs.
130 L & S	80 ft-lbs.	180 ft-lbs.	n/a	27 in-lbs.

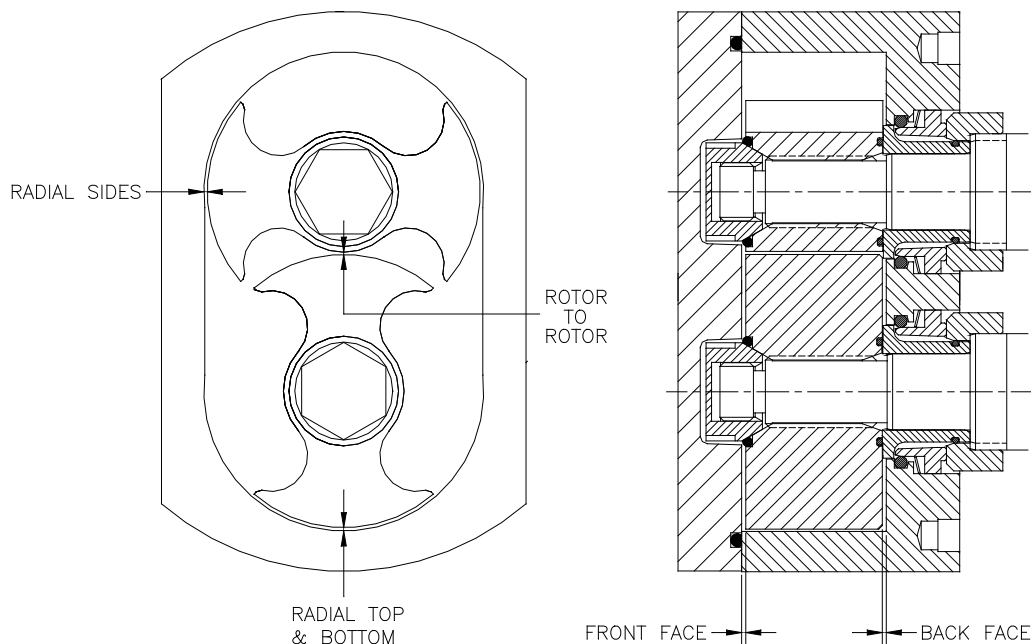

Figure 19

TABLE A3: FLII ROTOR CLEARANCES IN MILLIMETERS (REFERS TO FIGURE 19)

STANDARD FL II ROTOR CLEARANCES					
Model	Back Face	Front Face	Radial Sides	Radial Top & Bottom	Rotor to Rotor
15	0.06-0.08 (0.0024"-0.0031")	0.07-0.15 (0.0028"-0.0057")	0.09-0.12 (0.0036"-0.0046")	0.07-0.10 (0.0028"-0.0039")	0.07-0.12 (0.0028"-0.0047")
58S	0.1-0.13 (0.0039"-0.0051")	0.14-0.23 (0.0055"-0.009")	0.175-0.205 (0.0069"-0.0081")	0.115-0.145 (0.0045"-0.0057")	0.12-0.16 (0.0047"-0.0063")
58L					
75S	0.14-0.17 (0.0055"-0.0067")	0.20-0.29 (0.008"-0.011")	0.264-0.294 (0.010"-0.012")	0.14-0.20 (0.0055"-0.008")	0.125-0.185 (0.005"-0.007")
75L			0.325-0.358 (0.013"-0.014")	0.19-0.25 (0.0075"-0.010")	0.175-0.235 (0.0069"-0.009")
100S	0.19-0.23 (0.0075"-0.009")	0.23-0.33 (0.008"-0.011")	0.4-0.446 (0.016"-0.018")	0.18-0.34 (0.007"-0.013")	0.19-0.265 (0.0075"-0.010")
100L			0.485-0.531 (0.019"-0.021")	0.26-0.43 (0.010"-0.017")	0.275-0.35 (0.011"-0.014")
130S	0.19-0.23 (0.0075"-0.009")	0.23-0.33 (0.009"-0.013")	0.46-0.53 (0.018"-0.021")	0.26-0.35 (0.010"-0.014")	0.26-0.34 (0.010"-0.013")
130L	0.21-0.25 (0.008"-0.010")	0.32-0.42 (0.0125"-0.0165")	0.55-0.62 (0.022"-0.024")	0.35-0.44 (0.014"-0.0175")	0.35-0.43 (0.014"-0.017")

HIGH TEMPERATURE FL II ROTOR CLEARANCES					
Model	Back Face	Front Face	Radial Sides	Radial Top & Bottom	Rotor to Rotor
15	0.07-0.09 (0.0028"-0.0035")	0.085-0.165 (0.0033"-0.0065")	0.13-0.16 (0.005"-0.006")	0.11-0.14 (0.0043"-0.0055")	0.11-0.16 (0.0043"-0.0063")
58S	0.12-0.20 (0.0047"-0.008")	0.15-0.28 (0.006"-0.011")	0.215-0.245 (0.0085"-0.0096")	0.16-0.19 (0.006"-0.007")	0.16-0.2 (0.0063"-0.008")
58L					
75S	0.16-0.25 (0.0063"-0.010")	0.2-0.35 (0.008"-0.014")	0.3-0.33 (0.012"-0.013")	0.18-0.24 (0.007"-0.0094")	0.16-0.22 (0.0064"-0.009")
75L			0.35-0.38 (0.014"-0.015")	0.22-0.28 (0.0085"-0.011")	0.2-0.26 (0.008"-0.010")
100S	0.27-0.31 (0.011"-0.012")	0.29-0.39 (0.011"-0.015")	0.43-0.48 (0.017"-0.019")	0.21-0.37 (0.008"-0.015")	0.22-0.3 (0.009"-0.012")
100L			0.52-0.56 (0.020"-0.022")	0.29-0.46 (0.011"-0.018")	0.31-0.38 (0.012"-0.015")

TABLE A4: MAXIMUM SPEED _____

Pump Model	Max. Speed
15	1800 RPM
58L & S	1000 RPM
75L & S	800 RPM
100L & S	600 RPM
130 L & S	600 RPM

INSTALLATION

UNPACKING

Check the contents and all wrapping when unpacking the pump. Carefully inspect for any damage that may have occurred during shipping. Immediately report any damage to the carrier. Leave the protective caps over the pump inlet and outlet connections until you are ready to install the pump.

INSTALLING

Prior to actually installing the pump, ensure that:

- the pump will be readily accessible for maintenance, inspection and cleaning.
- adequate ventilation is provided for motor cooling.
- the drive and motor type is suitable for the environment where it is to be operated. Pumps intended for use in hazardous environments e.g., explosive, corrosive, etc., must use a motor and drive with the appropriate enclosure characteristics. Failure to use an appropriate motor type may result in serious damage and/or injury.

PIPING

Follow good piping practices when installing your FL II Series pump:

- Support all piping independently to minimize the forces exerted on the pump (*Figure 1*).
- Ensure that the piping can accommodate thermal expansion without stressing the pump.
- Slope inlet piping up to pump to avoid air pockets or if suction piping is larger than the pump inlet, use an eccentric reducer, straight side up, to prevent air pockets from forming. (*Figure 2*).
- Install a relief valve on the discharge side of the pump with a bypass loop back to the suction side to ensure that the pump cannot be over-pressurized.
- Use a check or “foot” valve on the inlet side of the pump in lift applications to keep the suction piping flooded.

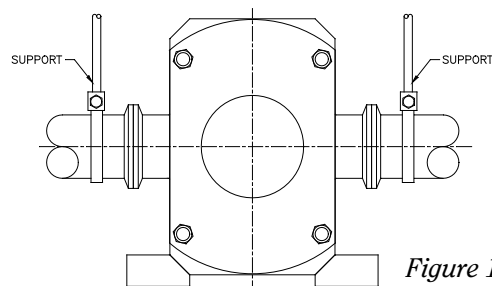

Figure 1

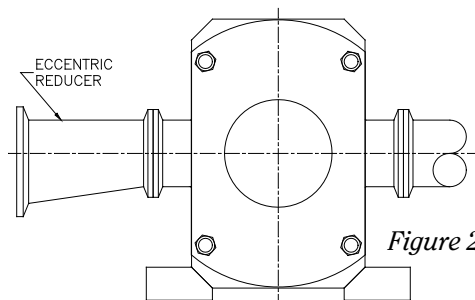

Figure 2

ALIGNMENT

In most cases, the pump will be shipped with a drive unit mounted on a common baseplate. The drive and pump are aligned at the factory; however, this alignment should be checked after installation (*Figure 3*). Misalignment between the pump and drive can result in premature bearing failure or other damage. If the pump is not shipped with a drive unit, use a flexible coupling between the pump and drive unit. Align the pump and drive unit according to the coupling requirements.

CHECKING ALIGNMENT

Remove the wire ring from the coupling sleeve and let it hang between the sleeve and one of the flanges.

To check the parallel alignment place a straight edge across the two coupling flanges and measure the maximum offset at various points around the periphery of the coupling without rotating the coupling. If the maximum offset exceeds the figure shown under “Parallel” in Table A1 (page 5), realign the shafts.

Check the angular alignment with a micrometer or caliper. Measure from the outside of one flange to the outside of the other (“Y”) at intervals around the periphery of the coupling. Determine the maximum and minimum dimensions without rotating the coupling. The difference between the maximum and minimum must not exceed the figure given under “Angular” in Table A1 (page 5). If a correction is necessary, be sure to recheck the parallel alignment.

Replace the wire ring on the O.D. of the coupling sleeve.

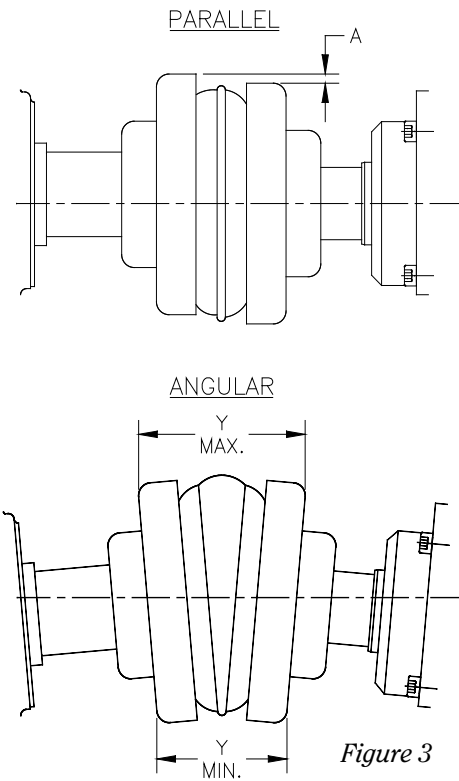

Figure 3

ELECTRICAL CONNECTIONS

Have an electrician connect the drive motor using sound electrical practices. Ensure that proper motor overload protection is provided. The size of the drive selected should meet the requirements of the operating conditions. A change in conditions (for example, higher viscosity product, higher product specific gravity, lower head losses) can overload the motor. For technical assistance regarding operating condition changes, please contact Fristam Pumps. Make sure that the pump is rotating in the correct direction.

WATER FLUSH CONNECTIONS

If your pump is equipped with a double mechanical seal, water must be supplied to provide cooling and lubrication. Connect supply and return lines to the water pipes supplied with product seal on your pump. See Figure 4 for the proper orientation.

Use about 3-12 gallons (11-45 lph) per hour of water at 1-2 psi (0.07 - 0.14 bar). Note: maximum pressure = 60 psi. Excessive seal pressure and/or flow rate through the product seal cavity may cause increased seal wear and shorten seal life.

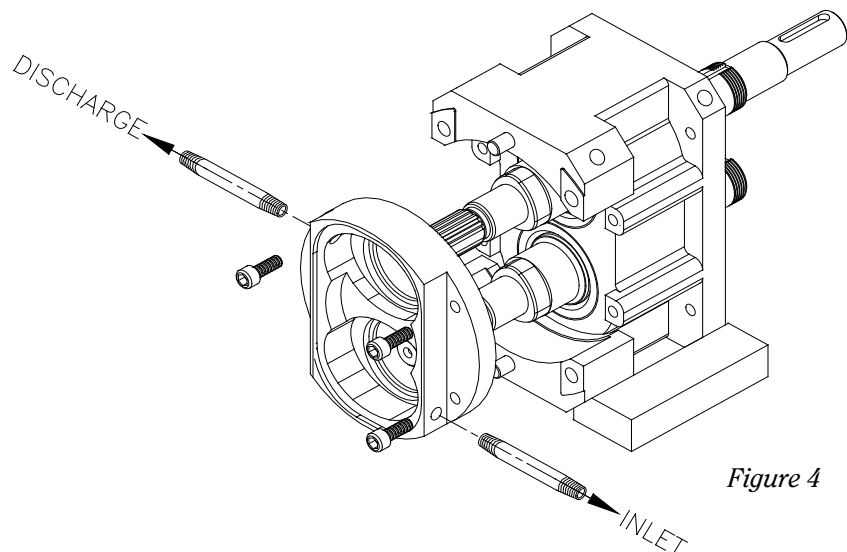

Figure 4

START-UP CHECK-LIST

1. Make sure that the pump and piping system are clear of any foreign matter. *Do not use the pump to flush the system.*
2. Make sure that the pump and drive are properly lubricated. Check the lubrication section (page 4) in this manual for the pump. See instructions from the drive manufacturer for the drive.
3. Check to make sure that all guards are in place and secure.
4. Check for proper pump and drive rotation. Make sure that the pump is flooded with product when checking the rotation. Running the pump dry even momentarily can cause seal damage.
5. Check that all valves on the discharge side are open to prevent over-pressurizing the pump. *Do not rotate the shafts with the cover removed. Rotors and housing could be damaged.*

CLEANING RECOMMENDATIONS

When you are running products or cleaning solutions with different temperatures, you need to allow enough time for all of the wetted components inside the pump to reach a steady-state temperature before you start the pump. If your process does not allow you to stop the pump during this transition, you need to install rotors that provide larger clearances. Please contact your Fristam representative for assistance.

If the process lines are to be cleaned with the pump, use a by-pass loop around the FL II pump during the CIP mode to maintain pip velocity. Once the wetted components are at a steady temperature, the pump can be started and run around 100 RPM with a backpressure of at least 10 PSI. As the product viscosity increases, the required backpressure may need to be increased as well.

Contact Fristam if you have any questions.

RECOMMENDED PREVENTIVE MAINTENANCE

RECOMMENDED TORQUE VALUES

Table A2, page 5.

RECOMMENDED SEAL MAINTENANCE

Visually inspect the mechanical seal regularly for leakage.

Annually replace the mechanical seal under normal conditions.

Replace the mechanical seal as often as required under severe conditions (abrasive product, dry running, etc.).

ELASTOMER INSPECTION

Inspect all elastomers when performing pump maintenance. We recommend replacing elastomers (o-rings and gaskets) during mechanical seal replacements.

LUBRICATION

Gears - The gears should be lubricated with an ISO 220 EP (Extreme Pressure) gear oil. The oil level should be maintained in the center of the sight glass on the side of the gearbox hous-

ing. The oil should be changed every 4000 hours under normal conditions and every 2000 hours under severe conditions. See the oil capacity listing on page 35.

•NOTE: on a vertical mount pump, if foaming occurs please use SAE 50 oil with non-foaming characteristics.

The front and rear bearings are sealed and greased for life.

Elastomers - Use a food grade lubricant on o-rings and gaskets unless otherwise specified. If using EPDM o-rings or gaskets, an oil-based lubricant can't be used.

PERIODIC MAINTENANCE

Periodically inspect the pump housing, cover and rotors for any signs of wear or damage. If wear is present this could be a sign of over pressurization, incorrect rotor gap or bearing wear.

SEAL REPLACEMENT



Begin all pump maintenance by disconnecting the energy source to the pump. Observe all lock out/tag out procedures as outlined by ANSI Z244.1-1982 and OSHA 1910.147 to prevent accidental start-up and injury.

TOOLS REQUIRED FOR SEAL REPLACEMENT:

<i>15:</i>	10 mm wrench 5 mm Allen wrench Flat cover tool 1" socket for flat cover tool	<i>100L & S:</i>	19 mm wrench 41 mm socket 6 mm Allen wrench
<i>58L & S:</i>	13 mm wrench 24 mm socket 6 mm Allen wrench Flat cover tool 1" socket for flat cover tool	<i>130 L & S:</i>	24 mm wrench 50 mm socket
<i>75L & S:</i>	17 mm wrench 30 mm socket 5 mm Allen wrench Flat cover tool 1" socket for flat cover tool		

Tools for all models:

- Torque wrench
- 1/2" wooden dowel
- Soft-faced hammer
- Small flat blade screwdriver
- Feeler gauges

Figure 8-B: FL II 58 - 130 Single seal assembly

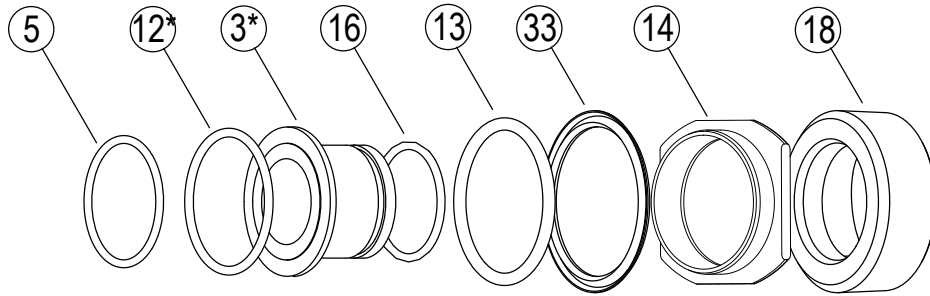

DESCRIPTION

- ⑤ ROTOR NUT O-RING
- ⑫* ROTOR O-RING
- ⑬ STATIONARY SEAL O-RING
- ⑳ SEAL WAVE SPRING
- ⑭ STATIONARY SEAL
- ⑯ GAPPING SPACER O-RING
- ③* GAPPING SPACER
- ⑱ ROTATING SEAL

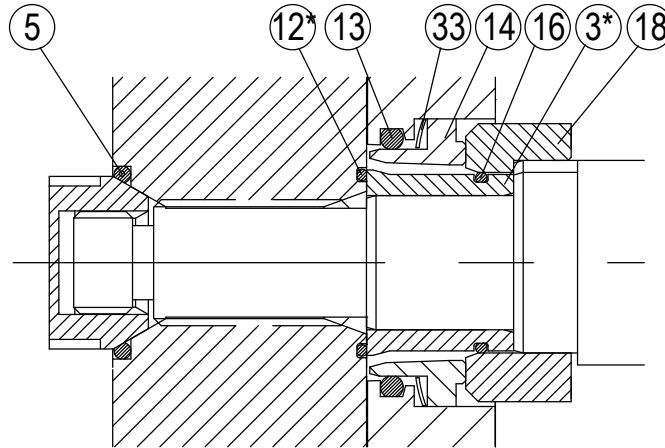

*PARTS NOT INCLUDED IN FLII 15 PUMPS PRIOR TO MARCH 2009

1265000528 Rev A

Figure 12-B: FL II 58 - 100 Double seal assembly

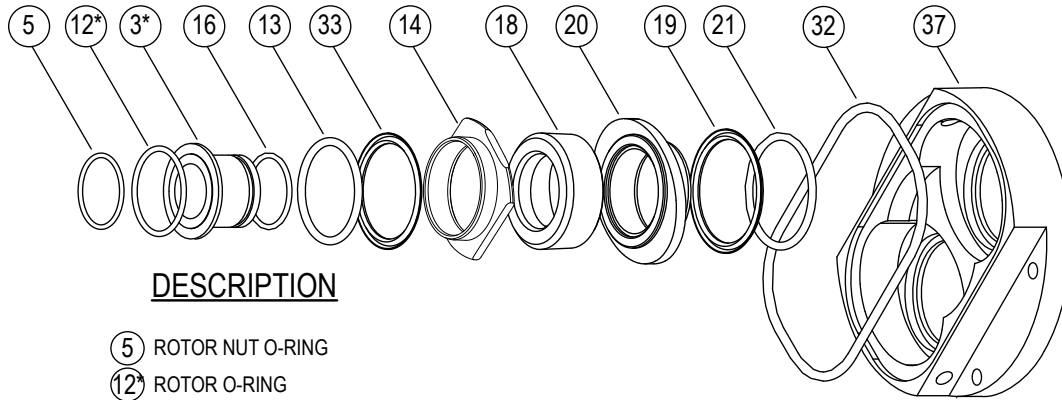

DESCRIPTION

- ⑤ ROTOR NUT O-RING
- ⑫* ROTOR O-RING
- ⑬ FRONT STATIONARY SEAL O-RING
- ③* GAPPING SPACER
- ⑯ GAPPING SPACER O-RING
- ⑳ FRONT SEAL SPRING
- ⑭ FRONT STATIONARY SEAL
- ⑱ ROTATING SEAL
- ㉔ REAR STATIONARY SEAL
- ⑲ REAR SEAL SPRING
- ㉕ REAR STATIONARY SEAL O-RING
- ㉖ SEAL FLUSH HOUSING O-RING
- ㉗ SEAL FLUSH HOUSING

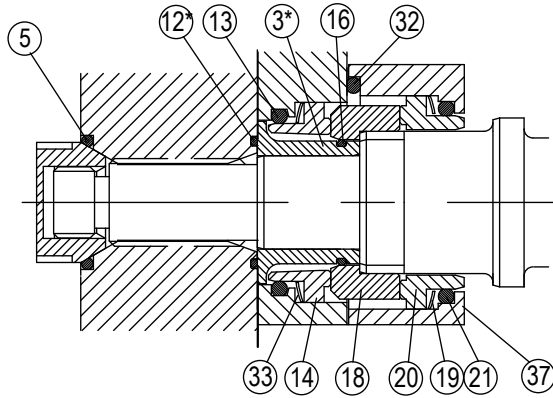

*PARTS NOT INCLUDED IN FLII 15 PUMPS PRIOR TO MARCH 2009

1265000529 Rev A

Figure 12: FL II 130 Double seal assembly

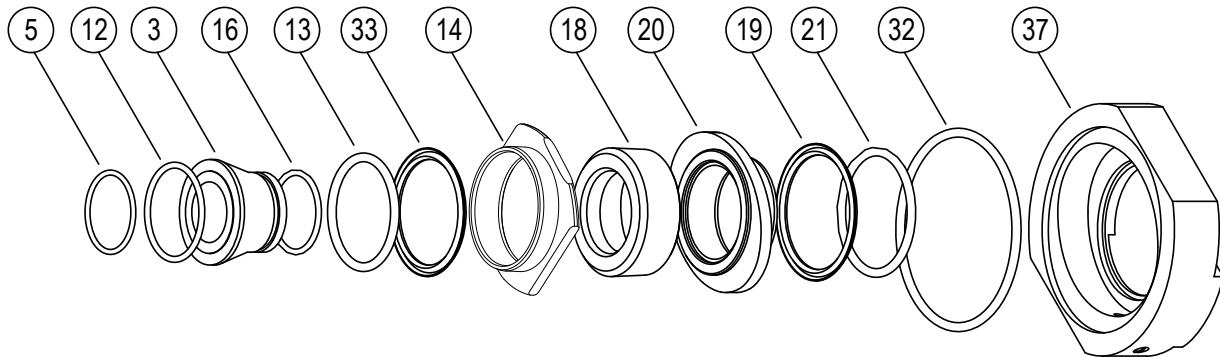

DESCRIPTION

- ⑤ ROTOR NUT O-RING
- ⑫ ROTOR O-RING
- ⑬ FRONT STATIONARY SEAL O-RING
- ③ GAPPING SPACER
- ⑯ GAPPING SPACER O-RING
- ⑳ FRONT SEAL SPRING
- ⑭ FRONT STATIONARY SEAL
- ⑱ ROTATING SEAL
- ㉔ REAR STATIONARY SEAL
- ⑲ REAR SEAL SPRING
- ㉕ REAR STATIONARY SEAL O-RING
- ㉖ SEAL FLUSH HOUSING O-RING
- ㉗ SEAL FLUSH HOUSING

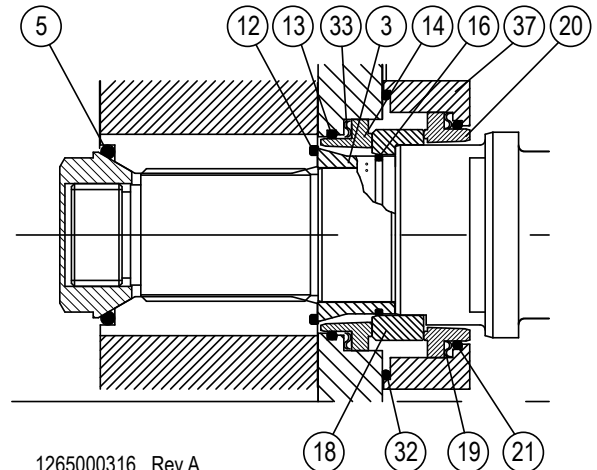

1265000316 Rev A

PUMP END DISASSEMBLY



WARNING

Drain all product from the pump head prior to disassembly. The pump head may be isolated with inlet and outlet valves. Disconnect the suction and discharge piping from the pump. Disconnect the seal flush supply

and return lines to your pump if the pump is equipped with a double mechanical seal.

- a) Loosen and remove the four cover dome nuts from the cover.
- b) Next remove the cover. If it is stuck, tap on the cover with a soft-faced hammer (*Figure 5*).
- c) Remove the cover o-ring.
- d) To remove the rotors, first loosen the first rotor, place the wooden dowel between the rotors as shown in *Figure 6*.
- e) Turn the first rotor nut counter-clockwise.
- f) Remove the rotor nut and o-ring.
- g) To loosen the other rotor, place the wooden dowel between the rotors on the opposite side of the pump. Again turn the rotor nut counter-clockwise.
- h) Remove the rotor nut and o-ring.
- i) The rotors and rotor o-rings can now be removed from the pump housing by pulling straight. Handle the rotors with care to avoid damage. While removing the rotors watch for the stamped markings. There should be one dot on the rotor for the drive shaft and two dots on the rotor for the idle shaft.

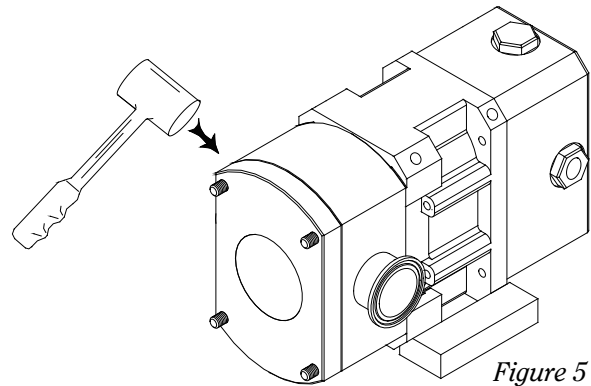

Figure 5

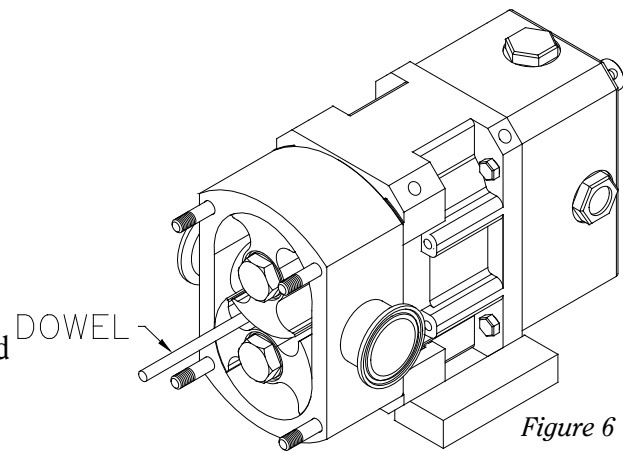

Figure 6

REMOVE THE MECHANICAL SEAL

- a) Remove the two housing nuts securing the pump housing to the gearbox.
- b) Slide the pump housing away from the gearbox. If the housing is stuck, alternately tap on the inlet and outlet ports with a soft-faced hammer (*Figure 7*). *Note:* the gapping spacers and the rotating seals will come off with the pump housing (except for the FL II 15).
- c) Clean and examine all of the pump components for damage. Replace damaged components as required. Fristam recommends replacing all of the wetted elastomers during reassembly.

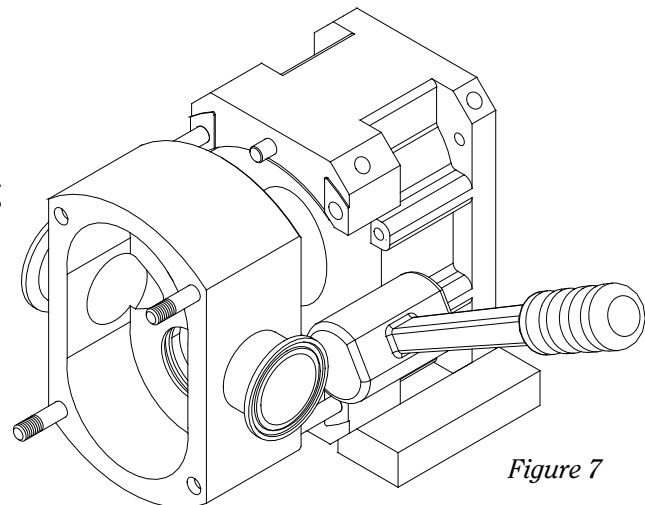
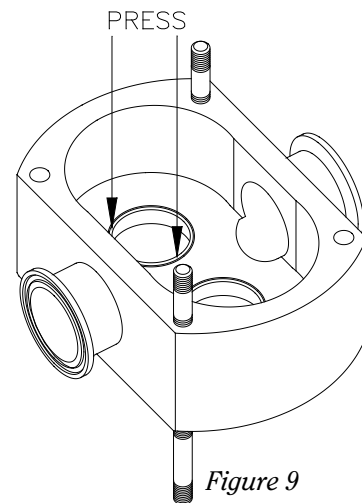

Figure 7

- d) Pull the rotating seals off the gapping spacers and remove both from the pump housing.
- e) Place the pump housing face up on a bench and rest it on the housing studs.
- f) Place your thumbs on the ID of the front stationary seals and push downward to press the stationary seals out of the pump housing (*Figure 9*).
- g) The front seal springs will come out with the stationary seals.
- h) Turn the pump housing over. Use a small flat blade screwdriver to remove the front stationary seal o-rings from the grooves in the pump housing (*Figure 10*).
- i) Discard the o-rings.
- j) Remove the gapping spacer o-rings from the grooves in the gapping spacers and discard.



ADDITIONAL DISASSEMBLY FOR DOUBLE SEAL ONLY

For pumps with double mechanical seals, you now have to remove the rear stationary seals.

- a) Remove the seal housing o-ring from the front of the seal flush housing.
FL II 15 only - pull off housing.
- b) Loosen the seal housing bolts with the Allen wrench.
- c) Place the seal flush housing face down on the bench. Place your thumbs on the ID of the rear stationary seals and push downward to press the stationary seals out of the seal flush housing (*Figure 11*).
- d) The rear seal springs and rear stationary seal o-rings will come out with the stationary seals. You are now ready to begin seal assembly.

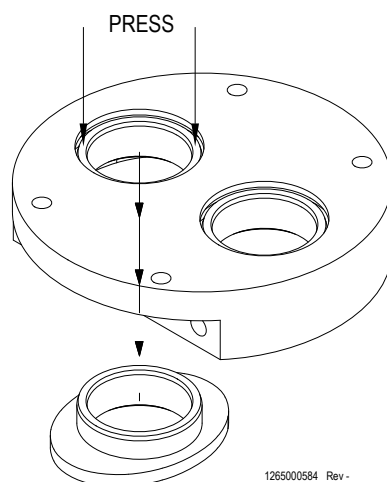
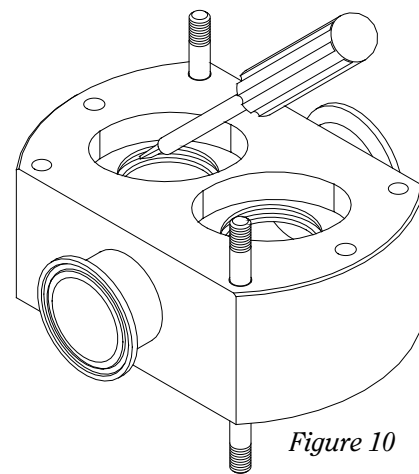

Figure 11 for models 15 - 100

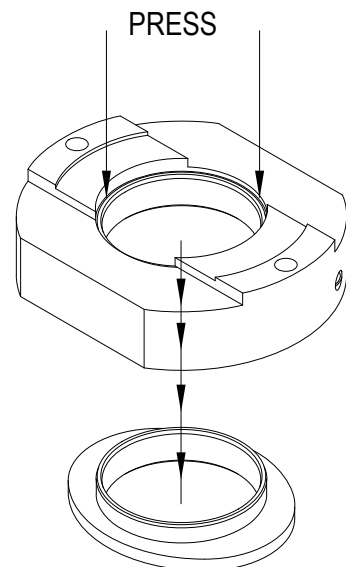

Figure 11 for model 130

SEAL ASSEMBLY – FOR DOUBLE SEAL ONLY

- a) Place the seal flush housing face up on a bench.
- b) Lubricate and install the rear stationary seal o-ring in the bottom of the stationary seal cavity.
- c) Install the rear stationary seal spring into the stationary recess.
- d) Install the rear stationary seals into the stationary seal cavity and press into place. Wipe the face of the stationary seals to remove any dirt or oil.
- e) Fasten the seal flush housing to the front of the gearbox.
- f) Install the seal flush housing o-ring onto the seal flush housing.

Finish assembling the seal as outlined in the “Seal Assembly” section.

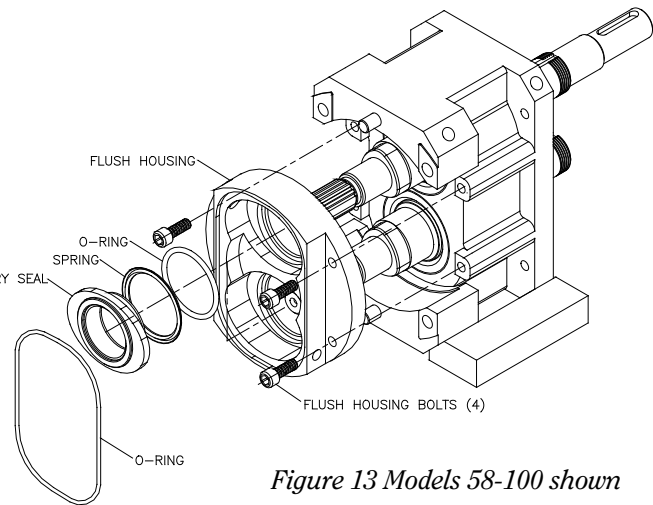
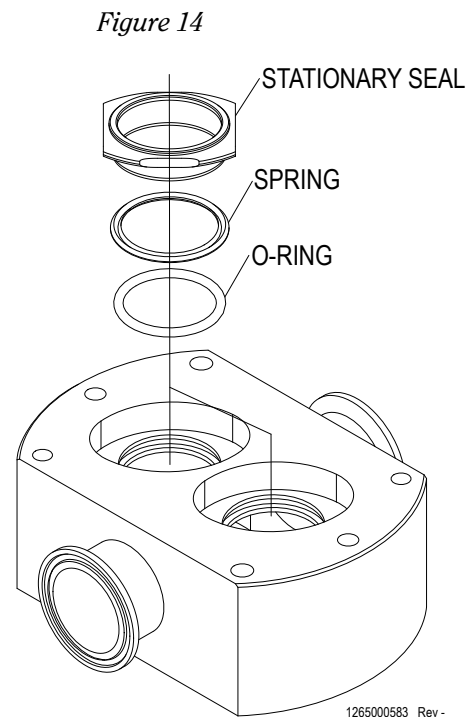

Figure 13 Models 58-100 shown

SEAL ASSEMBLY

Note: when installing the new seal components make sure that you use all of the components supplied with the replacement seal kit. Using some of the old components may reduce seal life.

- a) With the pump housing lying face down on a table, lubricate and install the front stationary seal o-ring in the housing o-ring groove.
- b) Place the stationary seal spring into the stationary seal cavity in the back of the housing (*Figure 14*).
- c) Use your thumbs to install the front stationary seal into the oval shaped stationary seal cavity in the back of the housing. Wipe the face of the stationary seals to remove any dirt or oil.
- d) Install the rotating seal onto the pump shaft (*Figure 15*). *Note:* the back of the rotating seal has a triangular recess that fits on to the triangular area of the shaft.



1265000583 Rev -

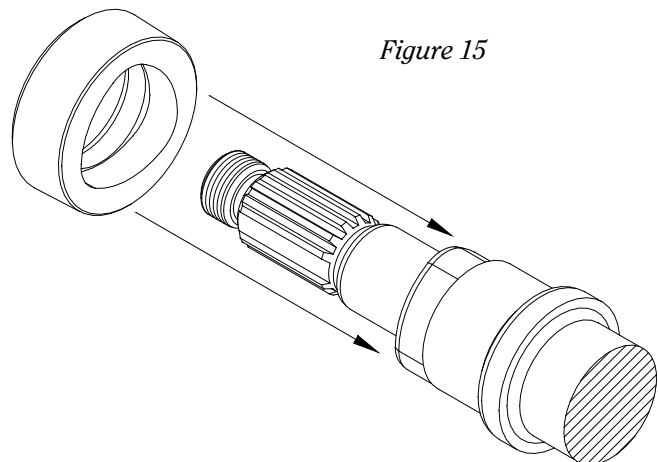

Figure 15

PUMP END ASSEMBLY

- a) Install the pump housing onto the gearbox and secure the housing dome nuts.

NOTE: FOR FL II 15 PRIOR TO MARCH 2009:

- b) Install the gapping spacer and rotor on to the appropriate shaft. Install the rotor with one dot onto the drive shaft and the rotor with two dots onto the idle shaft (*Figure 16a*).

FOR ALL OTHER MODELS:

- b) Install the gapping spacer o-ring into the o-ring groove on the gapping spacer.
 - Install the gapping spacer with one dot onto the drive shaft. Install the gapping spacer with two dots onto the idle shaft (*Figure 16*).
 - Install the rotor o-rings into the grooves on the back of the rotors (*Figure 17*).
 - Install the rotors, o-ring side first, into the pump housing. Install the rotor marked with one dot onto the drive shaft. Install the rotor with two dots onto the idle shaft. Note: the dots are located in the o-ring groove on the front of the rotor.

FOR ALL MODELS:

- c) Install the rotor nut o-rings into the rotor nut groove on the front of the rotor.
- d) Apply one drop of removable thread lock to the shaft threads and thread the rotor nuts onto the shaft in the clockwise direction.
- e) Place the wooden dowel between the rotors as shown in *Figure 18*. Tighten the first rotor nut with a socket wrench to the recommended torque (*Table A2, page 5*).

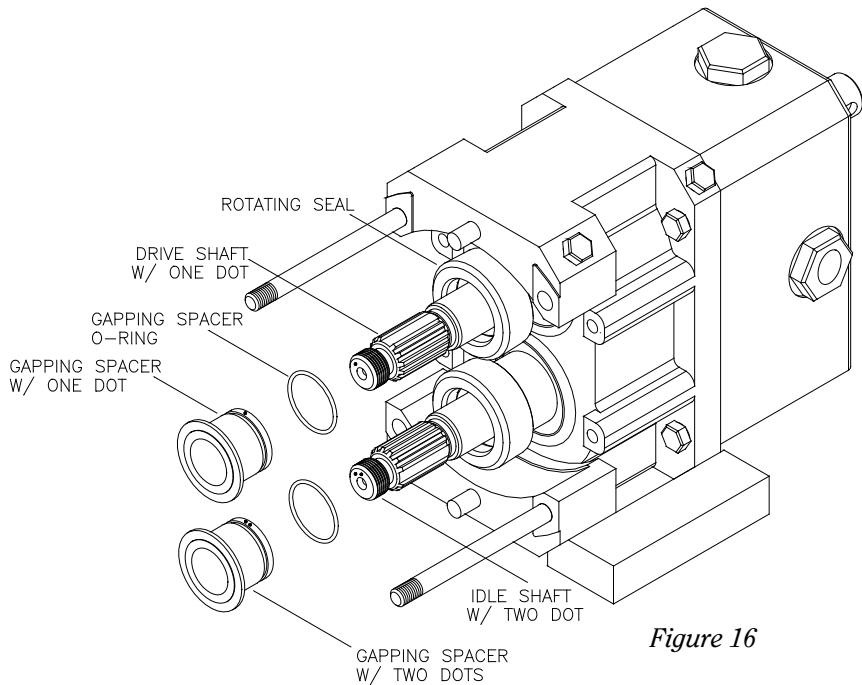

Figure 16

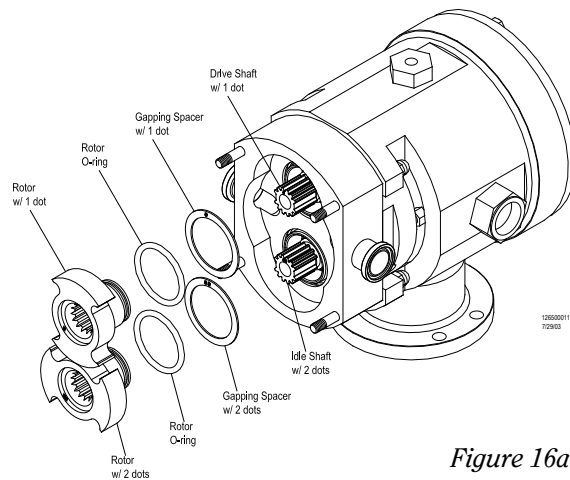

Figure 16a

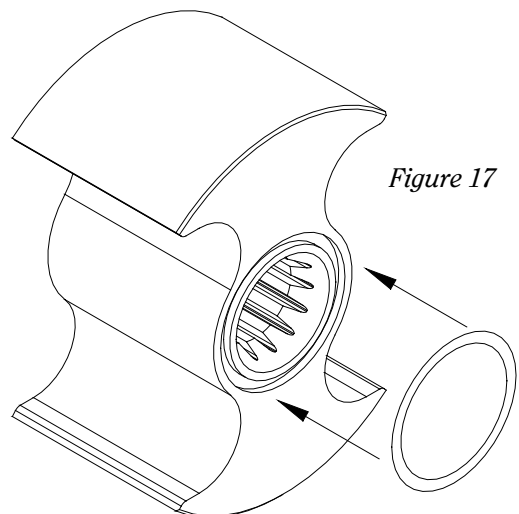

Figure 17

- f) To tighten the second rotor place the wooden dowel on the opposite side of the pump and tighten the second rotor nut to the proper torque.

Use feeler gauges to verify the back and radial clearances between the rotors and the housing. A depth gauge should be used to verify the front clearance (see *Table A3*).

BACK FACE CLEARANCE

The rotor to housing back face clearance is maintained by the gapping spacer.

To check the back clearance, mount the pump housing onto the gearbox.

Make sure to use washers and dome nuts on the long housings studs, to secure the housing. Assemble the gapping spacer, rotor and rotor nut onto the shaft. (Refer to *Table A2* for the proper rotor nut torque.) Measure the clearance between the back face of the pump housing and the back of the rotor with a feeler gauge. Check the reading with the recommended back face clearance, *Table A3*.

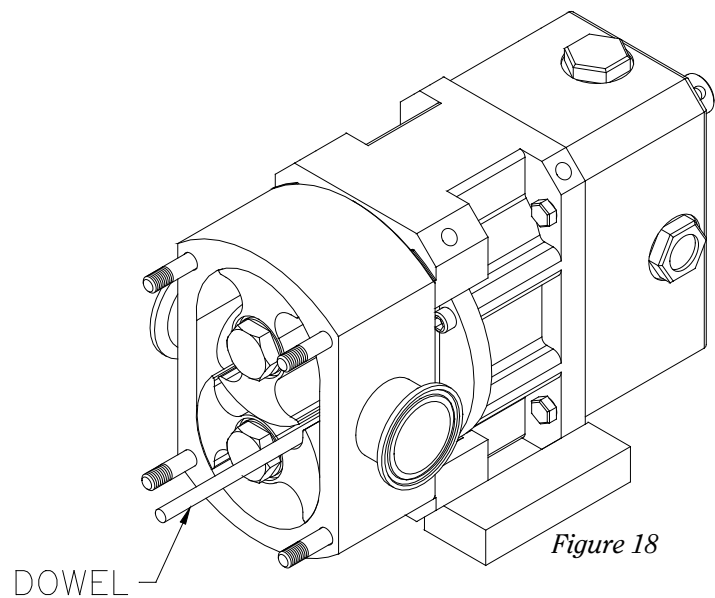

TOO MUCH CLEARANCE

If the clearance is greater than the clearance specified in *Table A3*, remove the gapping spacer or the rotor and gapping spacer on the FL II 15. Machine and lap the o-ring end of the gapping spacer to the required length. Lap the gapping spacer until the shim faces are perfectly flat and the spacer thickness is the same around the entire circumference of the shim. (Recommended lap compound – Liquid Diamond 14 microns)

Re-assemble the gapping spacer, rotor, and rotor nut. Recheck the back face clearance.

Assemble the pump wet end up as outlined in the “Pump End Assembly” section.

NOT ENOUGH CLEARANCE

If the back clearance is less than the clearance specified in *Table A3* a thicker shim must be added. Remove the gapping spacer. Install a new standard length gapping spacer. Follow the procedures outlined in the *Too Much Clearance* section above.

PUMP END ASSEMBLY (CONT.)

- g) Install the cover o-ring into the o-ring groove in the cover. Install the cover and tighten the dome nuts.
- h) Rotate the drive shaft to verify that the pump turns freely. *Do not rotate the shafts with the cover removed. Rotors and housing could be damaged.*
- i) Check that the oil level is in the center of the oil level sight glass.
- j) Install all required shaft guards. Install inlet and outlet piping. Verify that all valves on the suction and discharge side of the pump are open. Follow proper lockout procedures to re-supply the pump drive with the power. Start the pump.

SHAFT AND/OR BEARING REPLACEMENT (FOR FL II 15 - 130 MODELS)



Begin all pump maintenance by disconnecting the energy source to the pump. Observe all lock out/tag out procedures as outlined by ANSI Z244.1-1982 and OSHA 1910.147 to prevent accidental start-up and injury.

TOOLS REQUIRED FOR SHAFT AND/OR BEARING REPLACEMENT

15

- 10 mm wrench
- 5 mm Allen wrench

100 L & S

- 17 mm wrench
- 6 mm Allen wrench

Tools for all models:

- Spanner wrench
- Soft-faced hammer
- Indicating torque wrench
- Bearing heater

58 L & S

- 10 mm wrench
- 5 mm Allen wrench
- 10 mm tube for bearings

130 L & S

- 17 mm wrench
- 8 mm Allen wrench
- KM12 spanner wrench

75 L & S

- 10 mm wrench
- 5 mm Allen wrench
- 15 - 17 mm tube for bearings

- Wooden dowel
- Flat blade screwdriver
- Mild steel rod
- Arbor press (beneficial)

- Feeler gauges

GEARBOX DISASSEMBLY

Remove the oil drain plug and drain the oil.

Remove the coupling key from the drive shaft.

FL II 15 & 58: remove guards.

Remove the rear cover bolts from the rear cover.

Pull the rear cover off the drive shaft extension. If the cover sticks use a soft-faced hammer to loosen it.

Remove the rear cover oil seal from the rear cover and discard.

Remove the rear cover o-ring from the rear cover and discard.

Straighten the locking tab of the bearing lock washer. Reinstall the rotors on the drive and idle shafts. Lock the rotor with a wood dowel. Remove the lock nut and lock nut washer from the drive shaft and idle shaft.

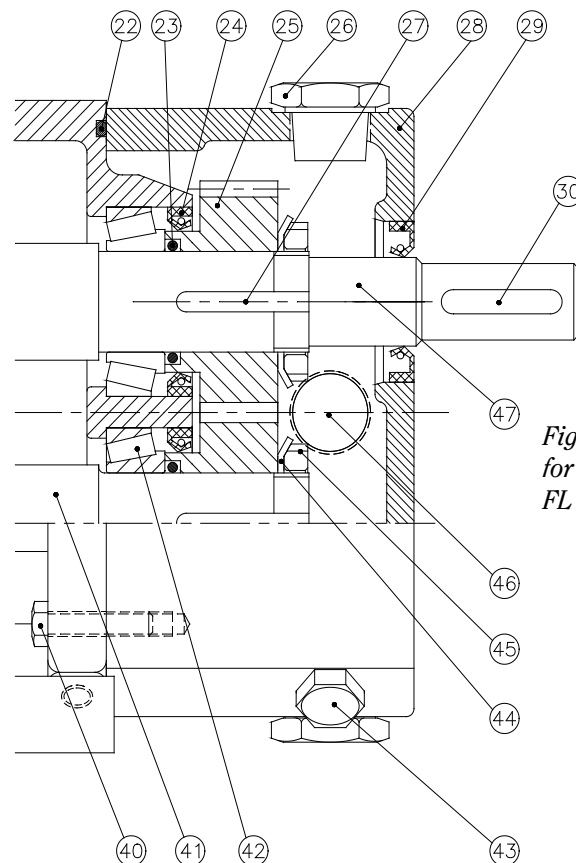

Figure 20
for models
FL II 55-100

Pull the two gears off the pump shafts. Remove the gear keys.

For FL II 75 - 130 only: Remove and discard the rear bearing o-rings from the pump shafts and rear bearing lip seals from the rear bearing bore.

Remove and discard the front bearing lip seals from the front bearing bore.

Place the gearbox, wet end down, on an arbor press.

Protect the shaft ends with a wood block and press the drive and idle shaft out of the gearbox.

Remove the rear bearing assemblies from the rear bearing bores and discard.

Remove and discard the rear bearing cups from the rear bearing bores.

Remove and discard the front bearing cups from the front bearing bores.

Heat the front bearing cones on the drive and idle shafts until they expand and drop off. Remove the bearing cones from the pump shafts.

GEARBOX ASSEMBLY

Position the gearbox with wet end up.

Unwrap the front bearing assemblies.

Insert the front bearing cups with the smaller inner diameter toward the inside of the gearbox, into the bearing bores until seated against the shoulder. There should be a tight sliding fit between the housing bore and the bearing cups.

Position the gearbox with the drive end up.

Unwrap rear bearing assemblies.

Insert the rear bearing cups, with the smaller inner diameter toward the inside of the gearbox, into the rear bearing bores until seated against the shoulder. There should be a tight sliding fit between the housing bore and the bearing cups.

Place the bi-wing rotors on a flat surface and insert the shafts into the rotor splines to stand them vertical on a flat surface.

Lubricate the front and rear bearing areas of the drive and idle shafts with grease.

Heat the front bearing cone to 250°F (110°C).

Place the cone and roller assembly over the shaft, with the larger outer diameter toward the rotor.

After the front bearing cone is cooled, use a .02 mm shim stock to check if the cone has moved. The shim stock should not be able to fit between the front bearing cone and shaft shoulder. If the shim can fit between the cone and shaft shoulder the cone will need to be pressed back into place. A piece of mild or stainless steel pipe cut to fit over the shaft and hammer could be used to seat the cone against the shaft shoulder. NOTE: Only tap on the inner cone of the race.

For FL II 75 - 130 only: Pack the front cone and roller assemblies with grease for both shafts.

Place the gearbox over the shafts.

For FL II 75 - 130 only: Generously apply grease to the rear bearing cups and insert into the rear bearing bore.

For FL II 75 - 130 only: Pack the rear cone and roller assemblies with grease then heat the cones to 250°F (110°C).

Place the cone and roller assemblies over the shafts with the smaller diameter end sliding over the shaft first. Tap them into place if necessary. Make sure that there is some endplay.

Lubricate the gear area of the shaft and the face of the lock washer, with oil.

For FL II 75 - 130 only: Place the rear bearing o-rings over the shafts and seat against the cone of the rear bearing.

For FL II 75 - 130 only: Lubricate the rear bearing lip seals with oil. Press the rear bearing lip seals into the rear bearing bores. The flat side of the seal goes inside the gearbox and the recessed side should face you.

Position both shaft gear keys to the 12:00 position.

Place the gear, lock washer and lock nut onto the shafts and hand tighten.

After the gears are installed, turn the shafts to make sure they turn freely and that the rotors are timed correctly.

Use a spanner wrench to tighten the bearing lock nut on the drive shaft.

Measure rolling torque with no load on bearing. Set the torque wrench to zero while rotating, this will remove the load caused by the lip seal.

For FL II 15 & 58: Measure rolling torque with no load on bearing, there should be zero endplay on the shafts.

The bearing locknut should be tightened until the rolling torque on the shaft measures the values in Table A3, Page 6.

Tighten the locknut on the idle shaft, following the previous steps.

For FL II 75 - 130 only: Measure the shaft endplay to be sure it is zero. If the endplay is not zero, repeat the tightening steps. To repeat these steps, the locknut will have to be backed off and the bearing will have to be tapped to remove the loading.

Lubricate and install the front bearing lip seals.

Lubricate and install the rear cover oil seal into the rear cover.

Install the rear cover o-ring and mount the rear cover assembly over the drive shaft extension onto the gearbox.

Fill the oil reservoir with oil to the middle of the sight glass.

FL II 15 PART NUMBERS

Item No.	Description	Qty.	Part No.	Item No.	Description	Qty.	Part No.
1	Mounting foot bolt	4	1101000129	28	Gearbox cover	1	1383001405
2	Mounting foot	1	1925001403	29	Rear oil seal	1	1812002503
3	Gapping shim (0.05mm)	2	0242200001	30	Coupling key	1	1315002621
	Gapping shim (0.03mm)	0	0242200002	31	Cover stud	2	1103001406
4	Rotor nut	2	1102004220	32	Seal flush housing o-ring (viton)	1	1180000234
5	Rotor nut o-ring (viton)	2	1180000379		Seal flush housing o-ring (EPDM)		1180000235
	Rotor nut o-ring (EPDM)		1180000393	33	Front seal spring	2	1820004238
6	Cover/Housing nut	8	1103004836	34	Water pipe	4	1910000011
7	Cover	1	1650621420	35	Housing stud	2	1103001407
8	Cover o-ring (viton)	1	1181000075	37	Seal flush housing	1	1845001480
	Cover o-ring (EPDM)		1181000557	38	Front oil seal	2	1812002516
10	Housing	1	1650611412	39	Front bearing	2	1173001002
11	Rotor (standard)	2	1650631408	40	Gearbox cover bolt	4	1101000040
	Rotor (high temperature)		1650631409	41	Idle shaft	1	1382001461
12	Rotor o-ring (viton)	2	1180000326	42	Rear bearing	2	1173001002
	Rotor o-ring (EPDM)		1180000347	44	Bearing lock washer	2	1104001003
13	Front stationary seal o-ring (viton)	2	1180000380	45	Bearing lock nut	2	1103001004
	Front stationary seal o-ring (EPDM)		1180000395	46	Sight glass	1	1248002601
14	Front stationary seal (carbon)	2	1815604240	47	Drive shaft	1	1382001460
	Front stationary seal (silicon carbide)		1815604243	48	Guard screw	2	1101000130
15	Gearbox	1	1310601401	49	Guard	2	1936001437
17	Pin	2	1891002618	50	Bolt	4	1101000131
18	Rotating seal (chrome oxide/SS)	2	1810604241	51	Distance screw	2	1891001439
	Rotating seal (silicon carbide)		1810604244	Notes:			
19	Rear seal spring	2	1820004239				
20	Rear stationary seal (carbon)	2	1815604242				
21	Rear stationary seal o-ring (buna)	2	1180000387				
22	Rear cover o-ring (buna)	1	1180000003				
25	Gear	2	1365001404				
26	Oil plug	1	1248002602				
27	Gear key	2	1315002619				

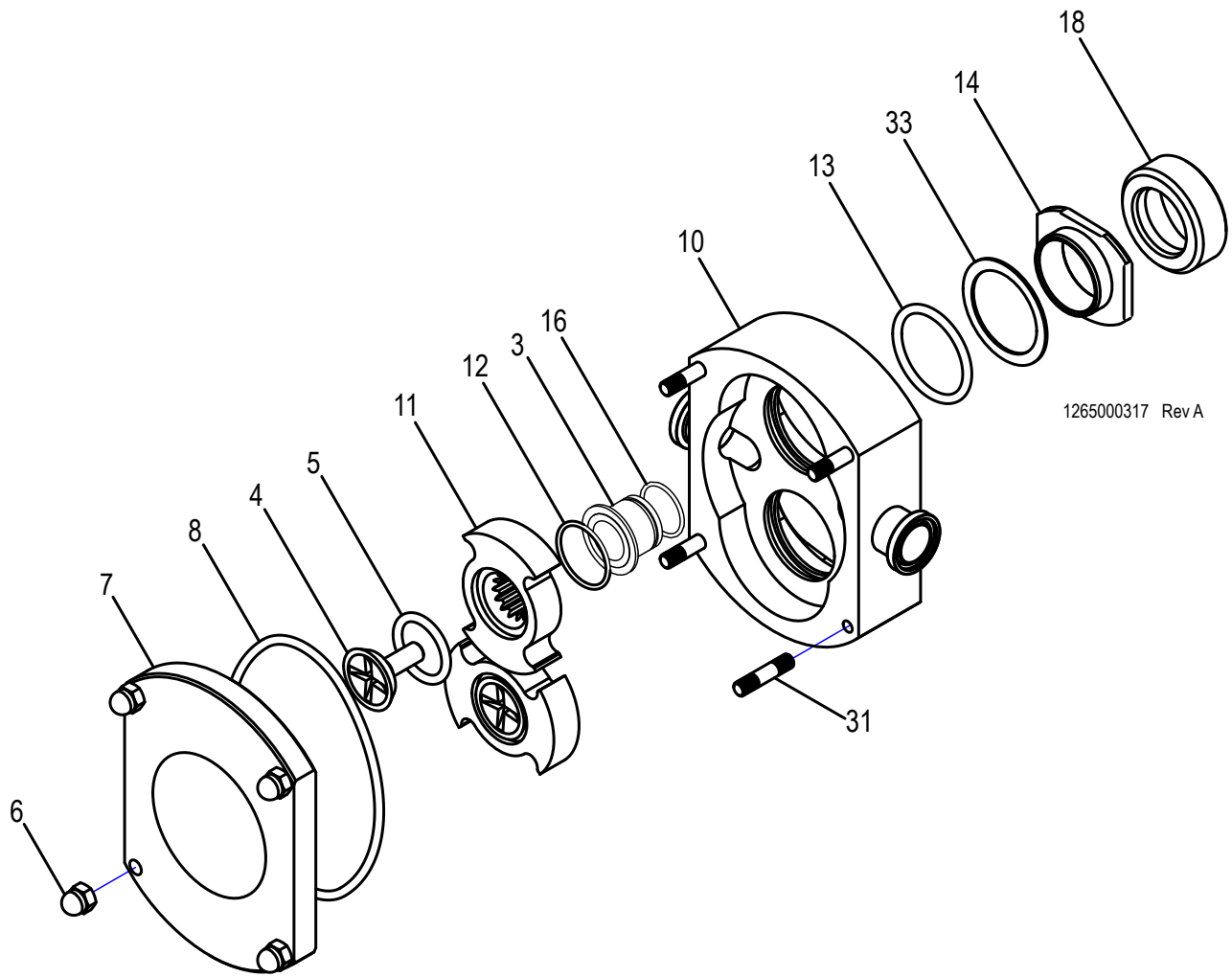

FL II 15 & 58 EXPLODED VIEW (SINGLE SEAL)

1	Mounting Foot Bolt	13	Front Stationary Seal O-ring
2	Mounting Foot	14	Front Stationary Seal
3	Gapping Spacer	15	Gearbox
4	Rotor Nut	16	Gapping Spacer O-Ring
5	Rotor Nut O-ring	17	Pin
6	Cover/Housing Nut	18	Rotating Seal
7	Cover	19	Rear Seal Spring (double seal only)
8	Cover O-ring	20	Rear Stationary Seal (double seal only)
10	Housing	21	Rear Stationary Seal O-ring
11	Rotor		(double seal only)
12	Rotor O-ring	22	Rear Cover O-ring

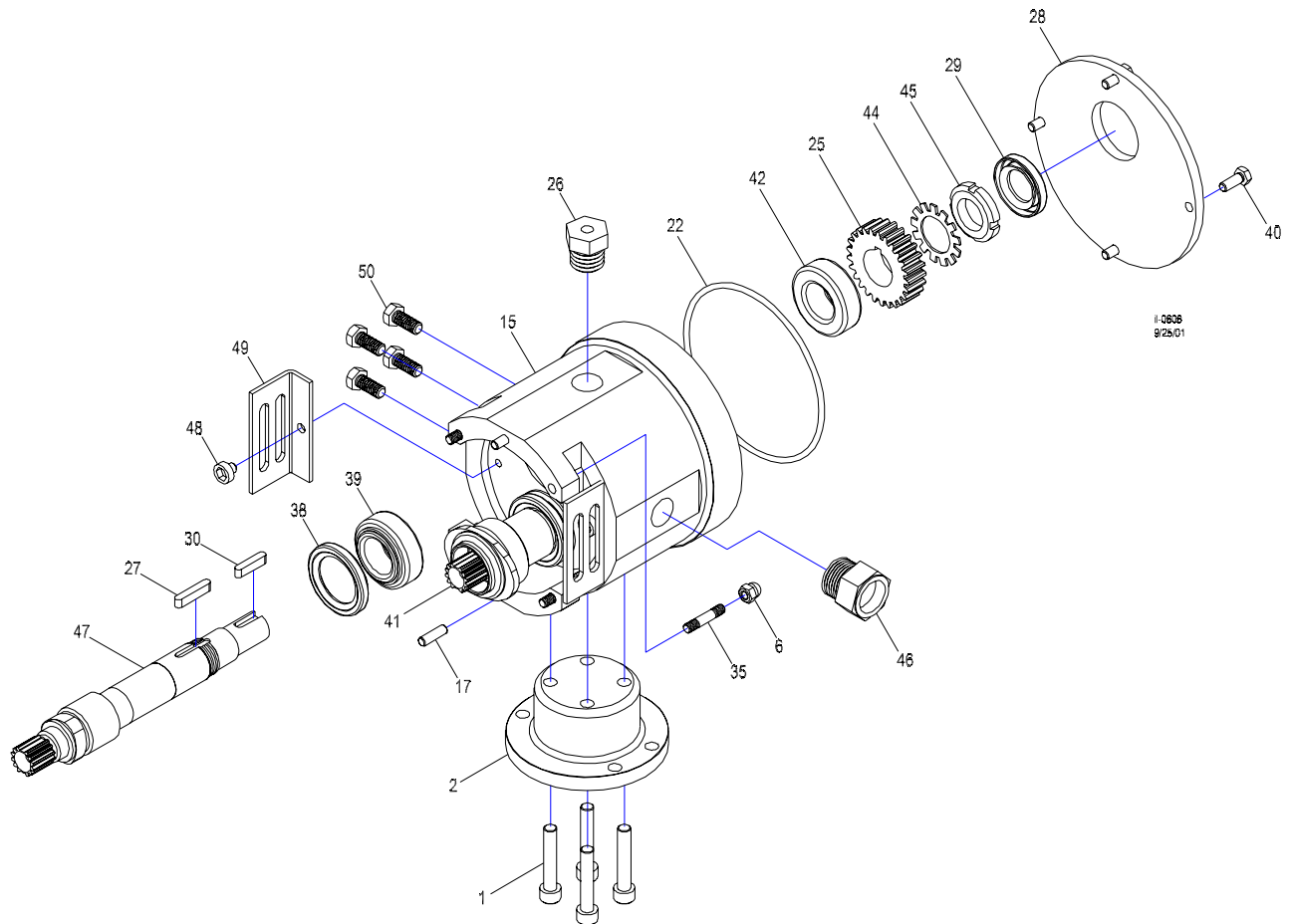

25	Gear	38	Front Oil Seal (double seal only)
26	Oil Plug	39	Front Bearing
27	Gear Key	40	Gearbox Cover Bolt
28	Gearbox Cover	41	Idle Shaft
29	Rear Oil Seal	42	Rear Bearing
30	Coupling Key	44	Bearing Lock Washer
31	Cover Stud	45	Bearing Lock Nut
32	Seal Flush Housing O-ring (double seal only)	46	Sight Glass
33	Front Seal Spring	47	Drive Shaft
34	Water Pipe	48	Guard screw (single seal only)
35	Housing Stud	49	Guard (single seal only)
37	Seal Flush Housing	50	Bolt
		51	Distance screw (double seal only)

FL II 58S PART NUMBERS

Item No.	Description	Qty.	Part No.	Item No.	Description	Qty.	Part No.
1	Mounting foot bolt	4	1101000129	28	Gearbox cover	1	1383001305
2	Mounting foot	1	1925001303	29	Rear oil seal	1	1812002503
3	Gapping shim	2	1224001330	30	Coupling key	1	1315002605
4	Rotor nut	2	1103003509	31	Cover stud	2	1103001506
5	Rotor nut o-ring (viton)	2	1180000379	32	Seal flush housing o-ring (viton)	1	1180000011
	Rotor nut o-ring (EPDM)		1180000393		Seal flush housing o-ring (EPDM)		1180000005
6	Cover/Housing nut	8	1103004836	33	Front seal spring	2	1820004238
7	Cover	1	1679621320	34	Water pipe	4	1910000011
8	Cover o-ring (viton)	1	1181000141	35	Housing stud	2	1103001506
	Cover o-ring (EPDM)		1181000081	37	Seal flush housing	1	1845001380
10	Housing	1	1678611312	38	Front oil seal	2	1812002517
11	Rotor (standard)	2	1678631308	39	Front bearing	2	1173001021
	Rotor (high temperature)		1678631312	40	Gearbox cover bolt	4	1101000040
12	Rotor o-ring (viton)	2	1180000326	41	Idle shaft	1	1382001397
	Rotor o-ring (EPDM)		1180000347	42	Rear bearing	2	1173001021
13	Front stationary seal o-ring (viton)	2	1180000380	44	Bearing lock washer	2	1104000023
	Front stationary seal o-ring (EPDM)		1180000395	45	Bearing lock nut	2	1103001012
14	Front stationary seal (carbon)	2	1815601340	46	Sight glass	1	1248002601
	Front stationary seal (silicon carbide)		1815601343	47	Drive shaft	1	1382001396
15	Gearbox	1	1310601301	48	Guard screw	2	1101000130
16	Gapping shim o-ring (viton)	2	1180000413	49	Guard	2	1936001437
	Gapping shim o-ring (EPDM)		1180000450	50	Bolt	4	1101000131
17	Pin	2	1891002606	51	Distance screw	2	1891001339
18	Rotating seal (chrome oxide/SS)	2	1810601341	Notes:			
	Rotating seal (silicon carbide)		1810601344				
19	Rear seal spring	2	1820004239				
20	Rear stationary seal (carbon)	2	1815604242				
21	Rear stationary seal o-ring (buna)	2	1180000569				
22	Rear cover o-ring (buna)	1	1180000568				
25	Gear	2	1365001304				
26	Oil plug	1	1248002602				
27	Gear key	2	1315002620				

FL II 58L PART NUMBERS

Item No.	Description	Qty.	Part No.	Item No.	Description	Qty.	Part No.
1	Mounting foot bolt	4	1101000129	28	Gearbox cover	1	1383001305
2	Mounting foot	1	1925001303	29	Rear oil seal	1	1812002503
3	Gapping shim	2	1224001330	30	Coupling key	1	1315002605
4	Rotor nut	2	1103003509	31	Cover stud	2	1103001506
5	Rotor nut o-ring (viton)	2	1180000379	32	Seal flush housing o-ring (viton)	1	1180000011
	Rotor nut o-ring (EPDM)		1180000393		Seal flush housing o-ring (EPDM)		1180000005
6	Cover/Housing nut	8	1103004836	33	Front seal spring	2	1820004238
7	Cover	1	1679621320	34	Water pipe	4	1910000011
8	Cover o-ring (viton)	1	1181000141	35	Housing stud	2	1103001506
	Cover o-ring (EPDM)		1181000081	37	Seal flush housing	1	1845001380
10	Housing	1	1678611352	38	Front oil seal	2	1812002517
11	Rotor (standard)	2	1679631362	39	Front bearing	2	1173001021
	Rotor (high temperature)		1679631349	40	Gearbox cover bolt	4	1101000040
12	Rotor o-ring (viton)	2	1180000326	41	Idle shaft	1	1382001399
	Rotor o-ring (EPDM)		1180000347	42	Rear bearing	2	1173001021
13	Front stationary seal o-ring (viton)	2	1180000380	44	Bearing lock washer	2	1104000023
	Front stationary seal o-ring (EPDM)		1180000395	45	Bearing lock nut	2	1103001012
14	Front stationary seal (carbon)	2	1815601340	46	Sight glass	1	1248002601
	Front stationary seal (silicon carbide)		1815601343	47	Drive shaft	1	1382001398
15	Gearbox	1	1310601301	48	Guard screw	2	1101000130
16	Gapping shim o-ring (viton)	2	1180000413	49	Guard	2	1936001437
	Gapping shim o-ring (EPDM)		1180000450	50	Bolt	4	1101000131
17	Pin	2	1891002606	51	Distance screw	2	1891001339
18	Rotating seal (chrome oxide/SS)	2	1810601341	Notes:			
	Rotating seal (silicon carbide)		1810601344				
19	Rear seal spring	2	1820004239				
20	Rear stationary seal (carbon)	2	1815604242				
21	Rear stationary seal o-ring (buna)	2	1180000569				
22	Rear cover o-ring (buna)	1	1180000568				
25	Gear	2	1365001304				
26	Oil plug	1	1248002602				
27	Gear key	2	1315002620				

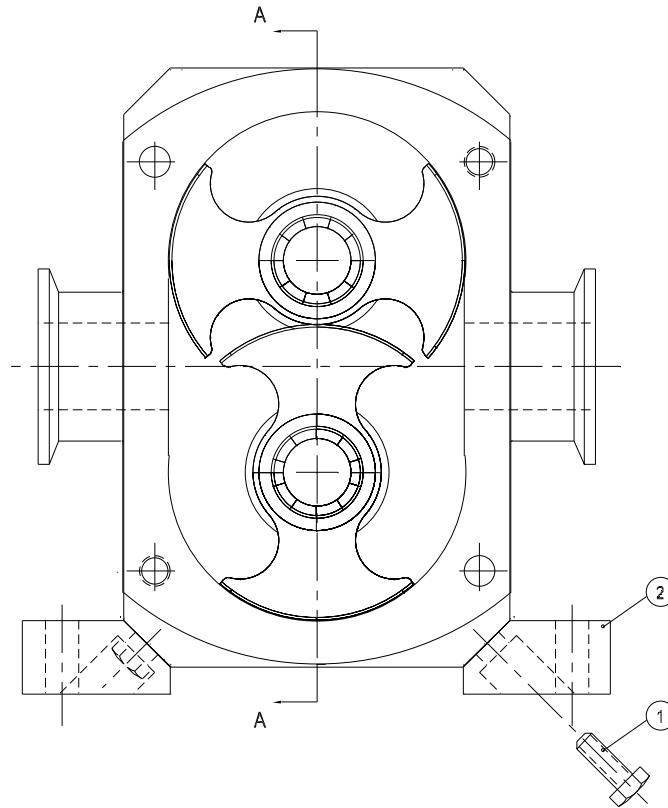

EXPLODED VIEW OF FLII 75 & 100

1	Mounting Foot Bolt	13	Front Stationary Seal O-ring
2	Mounting Foot	14	Front Stationary Seal
3	Gapping Spacer	15	Gearbox
4	Rotor Nut	16	Gapping Spacer O-ring
5	Rotor Nut O-ring	17	Housing Pins
6	Cover/Housing Dome Nuts	18	Rotating Seal
7	Cover	19	Rear Seal Spring
8	Cover O-ring	20	Rear Stationary Seal
9	Housing thru studs	21	Rear Stationary Seal O-ring
10	Pump Housing	22	Rear Cover O-ring
11	Rotor/Bi-wing Rotors	23	Rear Bearing O-ring
12	Rotor O-ring	24	Rear Bearing Lip Seal

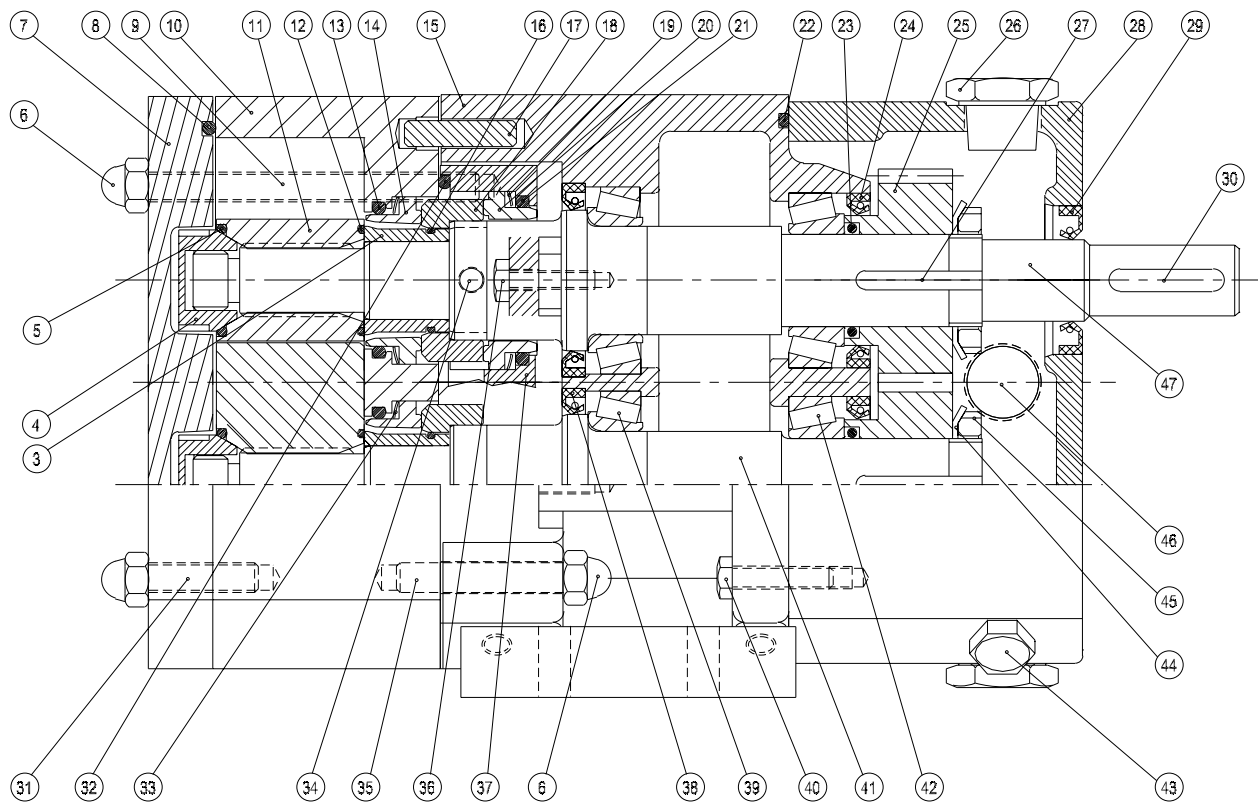

SECTION A-A

1285000319
11/18/05

- | | | | |
|----|---------------------------|----|------------------------|
| 25 | Gear | 38 | Front Bearing Lip Seal |
| 26 | Oil Fill Plug | 39 | Front Bearing |
| 27 | Gear Key | 40 | Rear Cover Bolt |
| 28 | Rear Cover | 41 | Idle Shaft |
| 29 | Rear Cover Oil Seal | 42 | Rear Bearing |
| 30 | Coupling Key | 43 | Drain Plug |
| 31 | Cover Studs | 44 | Bearing Lock Washer |
| 32 | Seal Flush Housing O-ring | 45 | Bearing Lock Nut |
| 33 | Front Seal Spring | 46 | Sight Glass |
| 34 | Water Pipe | 47 | Drive Shaft |
| 35 | Housing Studs | | |
| 36 | Flush Housing Bolts | | |
| 37 | Seal Flush Housing | | |

FL II 75S PART NUMBERS

Item No.	Part No.	Description	Quantity
1	1101000080	Mounting Foot Screw	4
2	1925004303	Foot (zinc plated)	2
2	1925004304	Foot (stainless steel)	2
2	1925004403	Vertical Mount Foot (zinc plated)	2
2	1925004404	Vertical Mount Foot (stainless steel)	2
3	1224004315	Gapping Spacer	2
4	1103003609	Rotor Nut	2
4	1102004420	Rotor Nut (flat cover)	2
5	1181000073	Rotor Nut O-ring (viton)	2
5	1181000079	Rotor Nut O-ring (epdm)	2
6	1101000137	Dome Nut	6
7	1687621620	Pump Cover	1
7	1687624320	Pump Cover (flat cover)	1
8	1181000072	Cover O-ring (viton)	1
8	1181000080	Cover O-ring (epdm)	1
9	1103004432	Thru Stud	2
10	1685614340	Pump Housing	1
11	1685634401	Rotor	2
12	1180000341	Rotor O-ring (viton)	2
12	1180000077	Rotor O-ring (epdm)	2
13	1180000044	Stationary Seal O-ring (viton)	2
13	1180000168	Stationary Seal O-ring (epdm)	2
14	1815604443	Front Stationary Seal (silicon carbide)	2
14	1815604440	Front Stationary Seal (carbon)	2
15	1310604301	Gearbox (cast iron)	1
15	1310604302	Gearbox (S.S.)	1
16	1180000350	Gapping Spacer O-ring (viton)	2
16	1180000076	Gapping Spacer O-ring (epdm)	2
17	1891002613	Pin	2
18	1810604444	Silicon Carbide Rotating	2
18	1810604441	Chrome Oxide Rotating	2
19	1820004439	Rear Spring	2
20	1815004440	Rear Stationary Seal (carbon)	2
21	1180000030	Rear Stationary Seal O-ring (buna)	2
22	1181000077	Rear Cover O-ring (buna)	1

Item No.	Part No.	Description	Quantity
23	1180000354	Gear O-ring (viton)	2
24	1812002508	Gear Lip Seal	2
25	1381001604	Gear	2
26	1248002602	Vent Plug	1
27	1315002611	Gear Key	2
28	1383004305	Rear Cover (cast iron)	1
28	1383004306	Rear Cover (S.S.)	1
29	1812002509	Rear Lip Seal	1
30	1315002638	Coupler Key	1
31	1103001606	Front Housing Stud	2
32	1180000389	Seal Flush Housing O-ring (buna)	1
33	1820004238	Front Spring	2
34	1910000012	Water Pipe	4
35	1103001607	Rear Housing Stud	2
36	1101000080	Flush Housing Bolt	4
37	1845004380	Seal Flush Housing	1
38	1812002510	Front Lip Seal	2
39	1173001009	Front Bearing	2
40	1101000127	Rear Cover Bolt	4
41	1382004322	Idle Shaft	1
41	1382004324	Idle Shaft (flat cover)	1
42	1173001010	Rear Bearing	2
43	1248000012	Drain Plug	1
44	1104001011	Lock Washer	2
45	1103001012	Gear Nut	2
46	1248002601	Sight Glass	2
47	1382004321	Drive Shaft	1
47	1382004323	Drive Shaft (flat cover)	1

FL II 75L PART NUMBERS

Item No.	Part No.	Description	Quantity
1	1101000080	Mounting Foot Screw	4
2	1925004303	Foot (zinc plated)	2
2	1925004304	Foot (stainless steel)	2
2	1925004403	Vertical Mount Foot (zinc plated)	2
2	1925004404	Vertical Mount Foot (stainless steel)	2
3	1224004315	Gapping Spacer	2
4	1103003609	Rotor Nut	2
4	1102004420	Rotor Nut (flat cover)	2
5	1181000073	Rotor Nut O-ring (viton)	2
5	1181000079	Rotor Nut O-ring (epdm)	2
6	1101000137	Dome Nut	6
7	1687621620	Pump Cover	1
7	1687624320	Pump Cover (flat cover)	1
8	1181000072	Cover O-ring (viton)	1
8	1181000080	Cover O-ring (epdm)	1
9	1103004433	Thru Stud	2
10	1687614360	Pump Housing	1
11	1687634411	Rotor	2
12	1180000341	Rotor O-ring (viton)	2
12	1180000077	Rotor O-ring (epdm)	2
13	1180000044	Stationary Seal O-ring (viton)	2
13	1180000168	Stationary Seal O-ring (epdm)	2
14	1815604443	Front Stationary Seal (silicon carbide)	2
14	1815604440	Front Stationary Seal (carbon)	2
15	1310604301	Gearbox (cast iron)	1
15	1310604302	Gearbox (S.S.)	1
16	1180000350	Gapping Spacer O-ring (viton)	2
16	1180000076	Gapping Spacer O-ring (epdm)	2
17	1891002613	Pin	2
18	1810604444	Silicon Carbide Rotating	2
18	1810604441	Chrome Oxide Rotating	2
19	1820004439	Rear Spring	2
20	1815004440	Rear Stationary Seal (carbon)	2
21	1180000030	Rear Stationary Seal O-ring (buna)	2
22	1181000077	Rear Cover O-ring	1

Item No.	Part No.	Description	Quantity
23	1180000354	Gear O-ring	2
24	1812002508	Gear Lip Seal	2
25	1381001604	Gear	2
26	1248002602	Vent Plug	1
27	1315002611	Gear Key	2
28	1383004305	Rear Cover (cast iron)	1
28	1383004306	Rear Cover (S.S.)	1
29	1812002509	Rear Lip Seal	1
30	1315002638	Coupler Key	1
31	1103001606	Front Housing Stud	2
32	1180000389	Seal Flush Housing O-ring (buna)	1
33	1820004238	Front Spring	2
34	1910000012	Water Pipe	4
35	1103001607	Rear Housing Stud	2
36	1101000080	Flush Housing Bolt	4
37	1845004380	Seal Flush Housing	1
38	1812002510	Front Lip Seal	2
39	1173001009	Front Bearing	2
40	1101000127	Rear Cover Bolt	4
41	1382004332	Idle Shaft	1
41	1382004334	Idle Shaft (flat cover)	1
42	1173001010	Rear Bearing	2
43	1248000012	Drain Plug	1
44	1104001011	Lock Washer	2
45	1103001012	Gear Nut	2
46	1248002601	Sight Glass	2
47	1382004331	Drive Shaft	1
47	1382004333	Drive Shaft (flat cover)	1

FL II 100S PART NUMBERS

Item No.	Part No.	Description	Quantity
1	1101000007	Mounting Foot Screw	4
2	1925004503	Foot (zinc plated)	2
3	1224004515	Gapping Spacer	2
4	1103003709	Rotor Nut	2
5	1180000260	Rotor Nut O-ring (viton)	2
5	1180000394	Rotor Nut O-ring (epdm)	2
6	1103004835	Dome Nut	6
7	1692621720	Pump Cover	1
8	1180000330	Cover O-ring (viton)	1
8	1180000391	Cover O-ring (epdm)	1
9	1103004632	Thru Stud	2
10	1690614540	Pump Housing	1
11	1690634601	Rotor	2
12	1180000383	Rotor O-ring (viton)	2
12	1180000397	Rotor O-ring (epdm)	2
13	1180000253	Stationary Seal O-ring (viton)	2
13	1180000278	Stationary Seal O-ring (epdm)	2
14	1815004643	Silicon Carbide Stationary	2
14	1815004640	Carbon Stationary	2
15	1310604501	Gearbox (cast iron)	1
16	1180000343	Gapping Spacer O-ring (viton)	2
16	1180000396	Gapping Spacer O-ring (epdm)	2
17	1891002609	Pin	2
18	1810604644	Silicon Carbide Rotating	2
18	1810604641	Chrome Oxide Rotating	2
19	1820000029	Rear Spring	2
20	1815604640	Rear Seal (carbon)	2
21	1180000253	Rear Stationary Seal O-ring (viton)	2
22	1180000385	Rear Cover O-ring	1
23	1180000378	Gear O-ring	2
24	1812002505	Rear Lip Seal	2
25	1381001704	Gear	2

Item No.	Part No.	Description	Quantity
26	1248002602	Vent Plug	1
27	1315002607	Gear Key	2
28	1383004505	Rear Cover (cast iron)	1
29	1812002507	Rear Cover Lip Seal	1
30	1315002637	Coupler Key	1
31	1103001706	Front Housing Stud	2
32	1180000390	Seal Flush Housing O-ring (buna)	1
33	1820000029	Front Spring	2
34	1910000013	Water Pipe	4
35	1103001707	Rear Housing Stud	2
36	1101000080	Flush Housing Bolt	4
37	1845004580	Seal Flush Housing	1
38	1812002504	Front Lip Seal	2
39	1173001005	Front Bearing	2
40	1101000136	Rear Cover Bolt	4
41	1382004522	Idle Shaft	1
42	1173100008	Rear Bearing	2
43	1248002614	Drain Plug	1
44	1104001021	Lock Washer	2
45	1103001008	Gear Nut	2
46	1248002601	Sight Glass	2
47	1382004521	Drive Shaft	1

FL II 100L PART NUMBERS

Item No.	Part No.	Description	Quantity
1	1101000007	Mounting Foot Screw	4
2	1925004503	Foot (zinc plated)	2
3	1224004515	Gapping Spacer	2
4	1103003709	Rotor Nut	2
5	1180000260	Rotor Nut O-ring (viton)	2
5	1180000394	Rotor Nut O-ring (epdm)	2
6	1103004835	Dome Nut	6
7	1692621720	Pump Cover	1
8	1180000330	Cover O-ring (viton)	1
8	1180000391	Cover O-ring (epdm)	1
9	1103004633	Thru Stud	2
10	1692614560	Pump Housing	1
11	1692634611	Rotor	2
12	1180000383	Rotor O-ring (viton)	2
12	1180000397	Rotor O-ring (epdm)	2
13	1180000253	Stationary Seal O-ring (viton)	2
13	1180000278	Stationary Seal O-ring (epdm)	2
14	1815604643	Silicon Carbide Stationary	2
14	1815604640	Carbon Stationary	2
15	1310604501	Gearbox (cast iron)	1
16	1180000343	Gapping Spacer O-ring (viton)	2
16	1180000396	Gapping Spacer O-ring (epdm)	2
17	1891002609	Pin	2
18	1810604644	Silicon Carbide Rotating	2
18	1810604641	Chrome Oxide Rotating	2
19	1820000029	Rear Spring	2
20	1815004640	Rear Seal (carbon)	2
21	1180000253	Rear Stationary Seal O-ring (viton)	2
22	1180000385	Rear Cover O-ring	1
23	1180000378	Gear O-ring	2
24	1812002505	Rear Lip Seal	2
25	1381001704	Gear	2

Item No.	Part No.	Description	Quantity
26	1248002602	Vent Plug	1
27	1315002607	Gear Key	2
28	1383004505	Rear Cover (cast iron)	1
29	1812002507	Rear Cover Lip Seal	1
30	1315002637	Coupler Key	1
31	1103001706	Front Housing Stud	2
32	1180000390	Seal Flush Housing O-ring (buna)	1
33	1820000029	Front Spring	2
34	1910000013	Water Pipe	4
35	1103001707	Rear Housing Stud	2
36	1101000080	Flush Housing Bolt	4
37	1845004580	Seal Flush Housing	1
38	1812002504	Front Lip Seal	2
39	1173001005	Front Bearing	2
40	1101000134	Rear Cover Bolt	4
41	1382004532	Idle Shaft	1
42	1173000008	Rear Bearing	2
43	1248002614	Drain Plug	1
44	1104000021	Lock Washer	2
45	1103001008	Gear Nut	2
46	1248002601	Sight Glass	2
47	1382004531	Drive Shaft	1

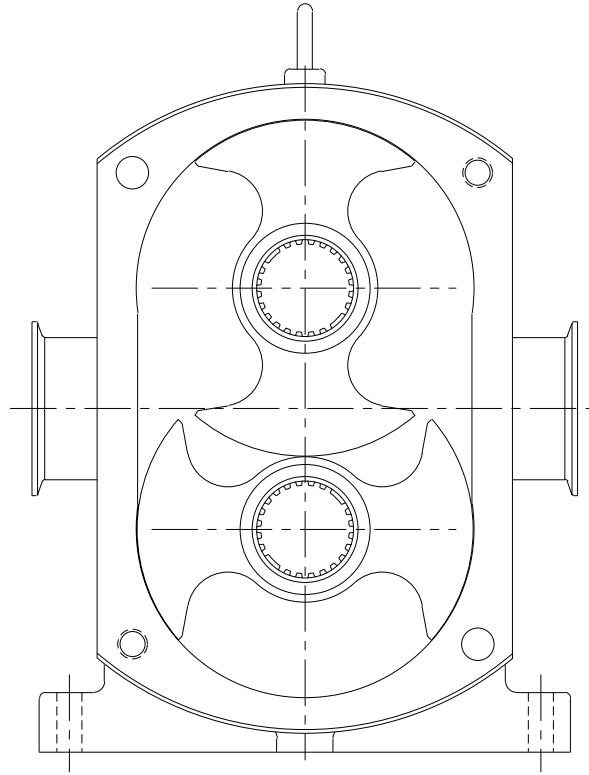

FL II 130 EXPLODED VIEW

3	Gapping Spacer	19	Rear Seal Spring
4	Rotor Nut	20	Rear Stationary Seal
5	Rotor Nut O-ring	21	Rear Stationary Seal O-ring
6	Cover/Housing Dome Nuts	22	Rear Cover O-ring
7	Cover	23	Rear Bearing O-ring
8	Cover O-ring	24	Rear Bearing Lip Seal
9	Housing thru studs	25	Gear
10	Pump Housing	26	Oil Fill Plug
11	Rotor/Bi-wing Rotors	27	Gear Key
12	Rotor O-ring	28	Rear Cover
13	Front Stationary Seal O-ring	29	Rear Cover Oil Seal
14	Front Stationary Seal	30	Coupling Key
15	Gearbox	31	Cover Studs
16	Gapping Spacer O-ring	32	Seal Flush Housing O-ring
17	Housing Pins	33	Front Seal Spring
18	Rotating Seal	34	Water Pipe

FL II 130S PART NUMBERS

Item No.	Part No.	Description	Quantity	Item No.	Part No.	Description	Quantity
3	1224004715	Gapping spacer	2	26	1248002602	Vent plug	1
4	1103001809	Rotor bolt	2	27	1315002635	Gear key	2
5	1180000384	Rotot bolt o-ring (viton)	2	28	1383001805	Rear cover (cast iron)	1
5	1180000392	Rotor bolt o-ring (EPDM)	2	29	1812002515	Rear cover oil seal	1
6	1103000010	Cover nut	6	30	1315002636	Coupling key	1
7	1692621820	Pump cover	1	31	1103001806	Cover studs	2
8	1181000074	Cover o-ring (viton)	1	32	1180000382	Seal flush housing o-ring (viton)	1
8	1181000082	Cover o-ring (EPDM)	1	33	1820004838	Front seal wave spring	2
9	1103004832	Housing stud FL II 130S	2	34	1910000013	Water pipe	4
10	1695614740	Pump housing with 3" clamp fittings	1	35	1103001807	Housing stud	2
10	1695614742	Pump housing with 4" clamp fittings	1	36	1103004834	Seal flush housing stud	4
11	1695634801	Rotor	2	37	1845004780	Seal flush housing	2
12	1180000233	Rotor o-ring (viton)	2	38	1812002513	Front oil seal	2
13	1180000381	Front stationary seal o-ring (viton)	2	39	1173001017	Front bearing	2
13	1180000365	Front stationary seal o-ring (EPDM)	2	40	1101000138	Rear cover bolt	4
14	1815004840	Front stationary seal (carbon)	2	41	1382004722	Idle shaft	1
14	1815004843	Front stationary seal (silicon carbide)	2	42	1173001018	Rear bearing	2
15	1310604702	Gearbox (cast iron) horizontal	1	43	1248002614	Oil drain plug	1
15	1310604701	Gearbox (cast iron) vertical	1	44	1104001019	Bearing lock nut washer	2
16	1180000115	Gapping spacer o-ring (viton)	2	45	1103001020	Bearing lock nut	2
16	1180000205	Gapping spacer o-ring (EPDM)	2	46	1248002601	Sight glass	2
17	1891002617	Housing pins	2	47	1382004721	Drive shaft	1
18	1810604841	Rotating seal (chrome oxide)	2	48	1101001826	Eyebolt	1
18	1810604844	Rotating seal (silicon carbide)	2		1936004717	Shaft guard	2
19	1820004839	Rear seal wave spring	2				
20	1815004842	Rear stationary seal (carbon)	2				
21	1180000388	Rear stationary seal o-ring (buna)	2				
22	1180000339	Rear cover o-ring (buna)	1				
23	1181000078	Rear Bearing o-ring	2				
24	1812002514	Rear oil seal	2				
25	1381001804	Gear	2				

FL II 130L PART NUMBERS

Item No.	Part No.	Description	Quantity
3	1224004715	Gapping spacer	2
4	1103001809	Rotor bolt	2
5	1180000384	Rotot bolt o-ring (viton)	2
5	1180000392	Rotor bolt o-ring (EPDM)	2
6	1103000010	Cover nut	6
7	1692621820	Pump cover	1
8	1181000074	Cover o-ring (viton)	1
8	1181000082	Cover o-ring (EPDM)	1
9	1103004833	Housing stud FL II 130L	2
10	1697614760	Pump housing - 4" clamp fittings	1
11	1695634801	Rotor	2
12	1180000233	Rotor o-ring (viton)	2
13	1180000381	Front stationary seal o-ring (viton)	2
13	1180000365	Front stationary seal o-ring (EPDM)	2
14	1815004840	Front stationary seal (carbon)	2
14	1815004843	Front stationary seal (silicon carbide)	2
15	1310604702	Gearbox (cast iron) horizontal	1
15	1310604701	Gearbox (cast iron) vertical	1
16	1180000115	Gapping spacer o-ring (viton)	2
16	1180000205	Gapping spacer o-ring (EPDM)	2
17	1891002617	Housing pins	2
18	1810604841	Rotating seal (chrome oxide)	2
18	1810604844	Rotating seal (silicon carbide)	2
19	1820004839	Rear seal wave spring	2
20	1815604842	Rear stationary seal (carbon)	2
21	1180000388	Rear stationary seal o-ring (buna)	2
22	1180000339	Rear cover o-ring (buna)	1
23	1181000078	Rear bearing o-ring (viton)	2
24	1812002514	Rear oil seal	2
25	1381001804	Gear	2

Item No.	Part No.	Description	Quantity
26	1248002602	Vent plug	1
27	1315002635	Gear key	2
28	1383001805	Rear cover (cast iron)	1
29	1812002515	Rear cover oil seal	1
30	1315002636	Coupling key	1
31	1103001806	Cover stud	2
32	1180000382	Seal flush housing o-ring (viton)	2
33	1820004838	Front seal wave spring	2
34	1910000013	Water pipe	4
35	1103001807	Housing stud	2
36	1103004834	Seal flush housing stud	4
37	1845004780	Seal flush housing	2
38	1812002513	Front oil seal	2
39	1173001017	Front bearing	2
40	1101000138	Rear cover bolt	4
41	1382004722	Idle shaft	1
42	1173001018	Rear bearing	2
43	1248002614	Oil drain plug	1
44	1104001019	Gear locknut washer	2
45	1103001020	Gear locknut	2
46	1248002601	Sight glass	2
47	1382004721	Drive shaft	1
48	1101001826	Eyebolt	1
	1936004717	Shaft guard	2

TROUBLESHOOTING

PROBLEM	CAUSE	SOLUTION
Pump not turning	Interruption of electrical power.	Reset circuit breaker, check fuses.
	Keys sheared or missing.	Replace.
	Coupler or belts are not connected.	Replace or adjust.
	Pump shaft or gears sheared.	Replace.
	Wrong rotation.	Reverse.
Pump not priming	Relief valve not properly adjusted.	Adjust valve.
	Valve closed in suction line.	Open valve.
	Suction line clogged or restricted.	Clear suction line.
	Air leak in connections or seal.	Repair leak.
	Pump speed too slow.	Increase speed.
	Suction line does not remain flooded.	Install foot valve.
	Air lock.	Bleed suction line.
Excessive clearances in pump.	Replace out of tolerance parts.	
Insufficient flow	NIPA low.	Increase suction pressure.
	Speed too low.	Adjust speed as required.
	Air leak.	Repair leak.
Noisy operation	Cavitation.	Increase NIPA.
	Viscous product.	Slow pump, reduce product.
	High vapor pressure, high temp.	Reduce temperature.
	Leaks in piping or pump.	Repair leaks.
	Dissolved gas in product.	Reduce discharge pressure.
	Mechanical noise.	Check tolerances.
	Excessive weight from piping, pump body distorted.	Support piping.
	Excessive discharge pressure.	Reduce discharge pressure.
	Worn bearing.	Replace bearing.
	Worn gears.	Replace gears.
Rotor-to-rotor contact.	Time rotors, replace twisted shafts, replace worn gears.	
Pump overloads	Viscosity of product higher than expected.	Reduce pump speed, increase piping size.
	Higher pressure than expected.	Reduce pump speed, increase piping size.
Play between gears	Worn gear teeth.	Replace gear.
	Gear loose on shaft.	Inspect gear key, keyway and shaft. If all are undamaged, retighten the gear retaining nut. Check for backlash.

NOTICE OF TERMS, WARRANTY PROVISIONS INCLUDING DISCLAIMERS, CLAIMS AND LIMITATION OF LIABILITY

Prices and all terms and conditions of sale are established in current price sheets and are subject to change without notice. All orders are subject to acceptance by Fristam Pumps USA Limited Partnership.

Each Fristam Pumps item is warranted to be free from manufacturing defects for a period of one (1) year from the date of shipment, providing it has been used as recommended and in accordance with recognized piping practice, and providing it has not been worn out due to severe service, such as encountered under extremely corrosive or abrasive conditions.

THIS WARRANTY IS EXPRESSLY IN LIEU OF ANY OTHER WARRANTIES EXPRESSED OR IMPLIED, INCLUDING BUT NOT LIMITED TO, ANY IMPLIED WARRANTY OF MERCHANTABILITY OR FITNESS FOR PARTICULAR PURPOSE. ALL OTHER WARRANTIES WHATSOEVER, EXPRESSED OR IMPLIED BY LAW OR OTHERWISE, ARE HEREBY EXCLUDED.

All claims must be in writing and must be mailed or delivered by purchaser within thirty (30) days after purchaser learns of the facts upon which such claim is based. Any claim not made in writing and within the time period specified above shall be deemed waived.

PURCHASER'S SOLE AND EXCLUSIVE REMEDY AND FRISTAM PUMP'S MAXIMUM LIABILITY FOR CLAIMS ARISING HEREUNDER OR FOR NEGLIGENCE FOR ANY AND ALL LOSSES AND DAMAGES RESULTING FROM ANY CAUSE SHALL BE EITHER THE REPAIR OR REPLACEMENT OF DEFECTIVE ITEMS OR, AT FRISTAM PUMPS' OPTION, THE REFUND OF THE PURCHASE PRICE FOR SUCH ITEMS. IN NO EVENT, INCLUDING IN THE CASE OF A CLAIM FOR NEGLIGENCE, SHALL FRISTAM PUMPS BE LIABLE FOR INCIDENTAL OR CONSEQUENTIAL DAMAGES, INCLUDING LOSS OF PROFITS.

No person, including any representative employee or agent of Fristam Pumps is authorized to assume on behalf of Fristam Pumps any liability or responsibility in addition to or different from that described in this provision. Any and all representations, promises, warranties or statements that are in addition to or different from the terms of this provision are of no force or effect.

If any provision of this Notice is held to be invalid, such provision shall be severed and the remaining provisions shall continue to be in force.

