



AlfaDisc

All-welded Plate Heat Exchanger

Applications

AlfaDisc is suitable for most of the applications, such as general cooling and heating duties, condensation, evaporation, reboiling and stream heating.

Standard design

AlfaDisc is built on the Plate & Shell concept. It is able to withstand higher design pressure, is more compact, is better developed for fatigue applications, has the possibility for asymmetric flow and is cleanable on one side. These features in combination with an attractive price give us a range of competitive advantages over other welded concepts.

The AlfaDisc all-welded plate heat exchanger provides the thermal efficiency and compactness of a plate and frame unit under conditions that would normally call for a shell and tube unit.

Designed for use with liquids, gases and two-phase mixtures at pressure up to 100 bars (CE/PED) and 47 bars (ASME) and at temperatures up to 538°C, the Plate&Shell unit works well with aggressive media, such as organic solvents, steam heaters and interchangers that are beyond the capability of a gasketed unit. The unit is also available with removable core design.

Typical capacities

Liquid flow rate

Up to 139 kg/s (2085 gpm), depending on media, permitted pressure drop and temperature program.

Sizes

AlfaDisc 50
AlfaDisc 100
AlfaDisc 150

Working principle

The unit features a plate side and a shell side, which offer high pressure ratings. It has alternating channels for hot and cold media, and can offer true counter-current or co-current flow. Number of passes could be up to 4 on each side.

Nozzle sizes up to DN 400 can be accommodated on the shell side of the exchanger, offering higher steam and liquid flow rates. Nozzles on the plate side can be up to DN 150.



AlfaDisc 50

The AlfaDisc unit can be fabricated from dissimilar metals when only one side will be exposed to corrosive conditions.

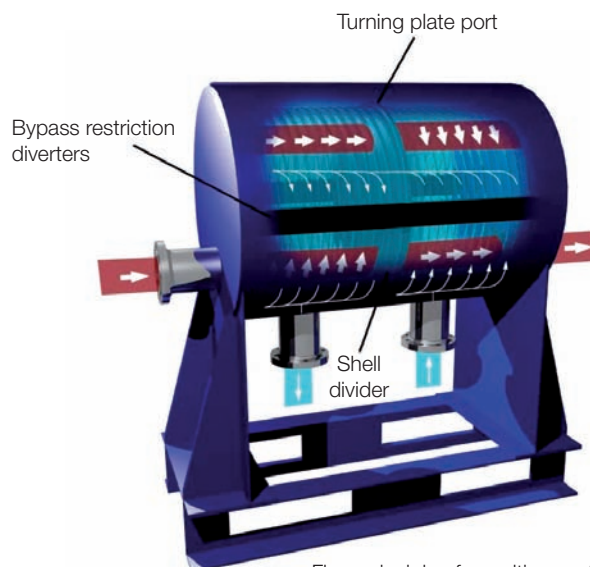

Flow principle of a multi-pass AlfaDisc.

TECHNICAL DATA

Design pressure

CE/PED Vacuum to 100 bars

ASME Vacuum to 47 bars

Design temperature

Carbon steel Shell -29 - 538°C

Stainless steel Shell -160 - 538°C

Standard design pressure (g) / temperature

HS ASME/PED 10 bar / -29 - 300°C

US ASME/PED 25 bar / -29 - 300°C

SS ASME/PED 40 bar / -29 - 300°C.

Maximum heat transfer surface

AlfaDisc 50 22 m² (235 sq.ft.)

AlfaDisc 100 66 m² (706 sq.ft.)

AlfaDisc 150 162 m² (1733 sq.ft.)

STANDARD MATERIALS

Shell Material

Mild steel, Epoxy painted or stainless steel

Cover Material

Mild steel, Epoxy painted or stainless steel

Nozzles

Stainless steel and Titanium

Could be combined with carbon steel flanges

Plate material

316L & Titanium

STANDARD CONNECTIONS

Sizes mm (inch)

AlfaDisc50 50 (2") 50-150 (2"- 6")

AlfaDisc100 100 (4") 100-300 (4"-12")

AlfaDisc150 150 (6") 150-400 (6"-16")

Pressure ratings

CE/PED PN16, 25&40

ASME ASME cl. 150, 300 & 600

AlfaDisc – PED/ASME approval pressure/temperature graph

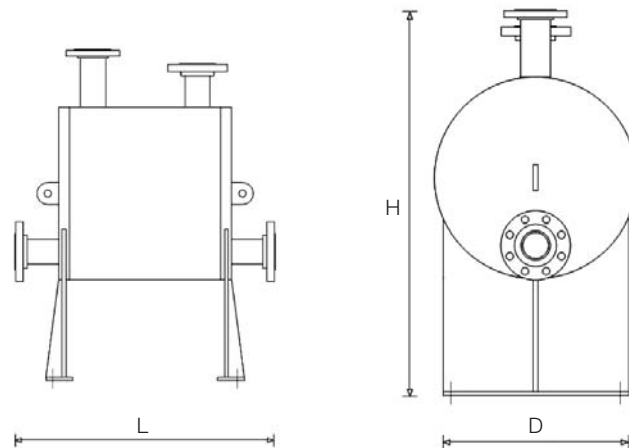
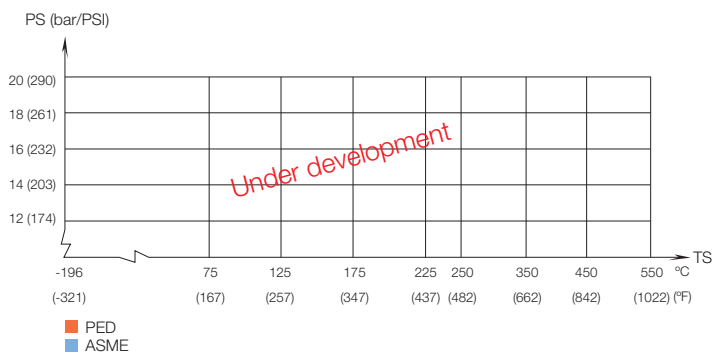

Measurements mm (inch)

	H	D	Lmin	Lmax
AD50	686(27)	305(12)	483(19)	1219(48)
AD100	1117(44)	559(22)	635(25)	1448(57)
AD150	2032(80)	863(34)	965(38)	1880(74)

Particulars required for quotation

- Flow rates or heat load
- Temperature program
- Physical properties of liquids in question (if not water)
- Desired working pressure
- Maximum permitted pressure drop
- Available steam pressure

How to contact Alfa Laval

Up-to-date Alfa Laval contact details for all countries are always available on our website at www.alfalaval.com.