



First Choice in Sanitary Applications - at low Capacity

Clip 3 Plate Heat Exchangers

Application

Pasteurization and general cooling/heating of dairy and brewery products, fruit juices and similar food products.

Working principle

The heat exchanger consists of a number of corrugated plates clamped together in a frame and sealed at the edges by means of gaskets.

The plates have ports at the corners and the gaskets are so arranged that the two media flow through alternate passages between the plates. The two media are separated by the plates and cannot be mixed. Heat is transferred through the plates, from the hot medium to the cold.

One unit can contain several heat exchangers, separated by connection plates with interchangeable connections.

Frame

The frame consists of a fixed frame plate, a movable pressure plate, an upper carrying bar, a lower guiding bar, a support column and tightening bolts with nuts.

The Clip 3-RM frame plate has adjustable feet and the Clip 3-RMV is without feet for wall mounting.

Plate

The corrugation of the plates provides a passage between the plates, supports each plate against the adjacent one and enhances the turbulence, resulting in efficient heat transfer.

The plates have a chevron pattern for maximum strength at high working pressures.

The plates are reversible and have parallel flow, which means only one type of plate is needed.

Gasket

The plates are supplied with glue-free Clip-On gaskets, which are easy to replace even with the plates still hanging in the frame.

No tools are needed to replace the gaskets.

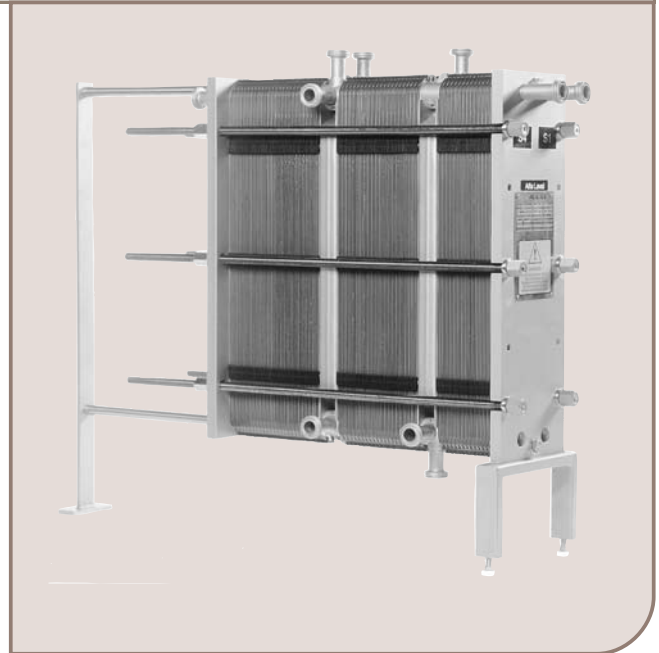

Clip 3-RM

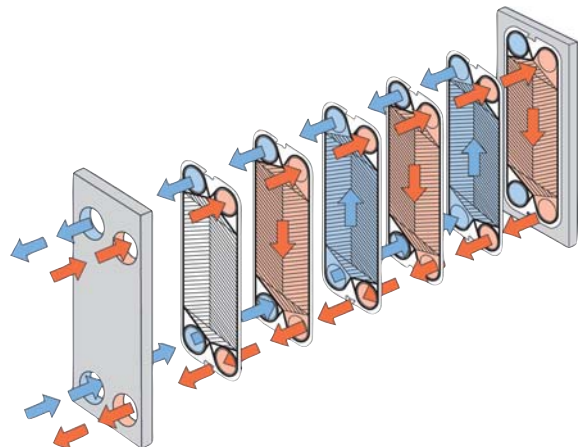

Flow principle of a plate heat exchanger

Standard Materials

Plates

Stainless steel AISI 316.

Gaskets

Nitrile-FDA, Clip-On design.

Frame

Connection plates of mild steel, clad with stainless steel in glass blasted finish. Nuts of chromium plated brass. All other parts of stainless steel.

Technical Data

Plates

Actual heating surface 0.058 m²

Connections

All connections 25 mm

SMS or DIN male parts.

Other union standards on request.

Mechanical design pressure (g) / Temperature

Frame RM - 10 bar/150°C

Complies with European Pressure Equipment Directive (PED), may carry the CE mark depending on the design conditions.

Capacity

Pasteurization 2,500 l/h

Heating/cooling 4,500 l/h

Water 8,000 l/h

Options

- A. Protection sheet
- B. 3-A finish
- C. Extra standard wrench
- D. Test certificates and material certificates
- E. Testing by authorized inspection companies

Dimensions (mm)

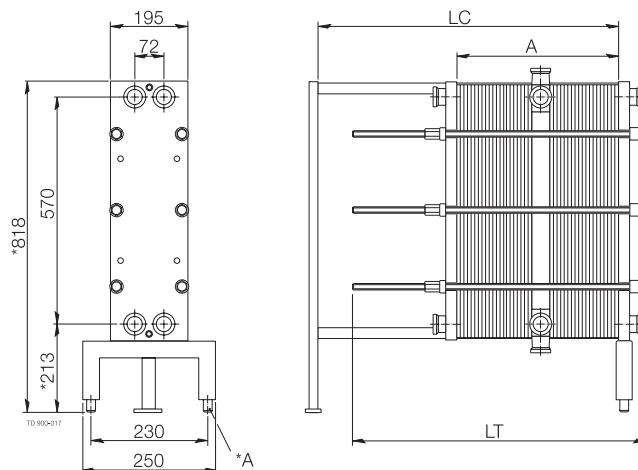

A) Adjustable feet +/- 15 mm

Overall length varies depending on numbers of plates and connecting plates. Recommended free space around the unit is 1 meter at sides and sufficient space at the frame head end to pull out the bolts

ESE00257EN 0701

The information contained herein is correct at the time of issue, but may be subject to change without prior notice.

How to contact Alfa Laval

Contact details for all countries are continually updated on our website. Please visit www.alfalaval.com to access the information direct.