

# Rear Connect X-Series

BIMETAL THERMOMETERS



- ▶ 3" Dial Size
- ▶ ± 1.0% Full Scale Accuracy
- ▶ Stainless Steel Case & Stem
- ▶ Hermetically Sealed Design

Perfect for OEM Applications

B831X04 shown

The Trerice **X-Series OEM Bimetal Thermometer** is designed to meet the demands of the OEM and industrial marketplace, but at an economical price. It features a hermetically sealed case with a narrow, space saving profile. This instrument does not include an external reset, ensuring tamperproof operation throughout the life of the unit.

- Optional features available: Please consult the Options & Accessories Section for details.

**Thermowell**

- For corrosive or pressure applications, use of a thermowell is recommended to prevent damage to the thermometer and facilitate its removal from the process (refer to pages 155-161).

For correct use and application of all Bimetallic thermometers, please refer to the Bimetallic Actuated Thermometer Standard ASME B40.3.

## Specifications

Model	Dial Size
B831X	3"
<b>Case</b>	300 stainless steel, hermetically sealed
<b>Stem</b>	300 stainless steel 1/4" diameter
<b>Coil</b>	Bimetallic, silicone dampened ranges to 300°F (148°F), above 300°F not dampened
<b>Connection</b>	Rear 1/2 NPT
<b>Window</b>	Polycarbonate
<b>Pointer</b>	Balanced, black finished
<b>Dial Face</b>	Aluminum, white background with black and blue graduations and markings
<b>External Reset</b>	No
<b>Accuracy</b>	±1.0 % Full Scale ASME B40.3 Grade A

### Approximate Shipping Weight

B831X: 0.5 lbs [0.22 kg]

## HOW TO ORDER

Sample Order Number: **B831X 04 05**

Model	Stem Length	Range Code
B831X	02 2 1/2" Stem	See Standard Ranges
	04 4" Stem	
	06 6" Stem	
	09 9" Stem	
	12 12" Stem	
	15 15" Stem	
	18 18" Stem	
	24 24" Stem	

Other lengths available: Specify in inches (72" maximum)

# Rear Connect X-Series

All dimensions are nominal. Dimensions in [ ] are in millimeters.

BIMETAL THERMOMETERS

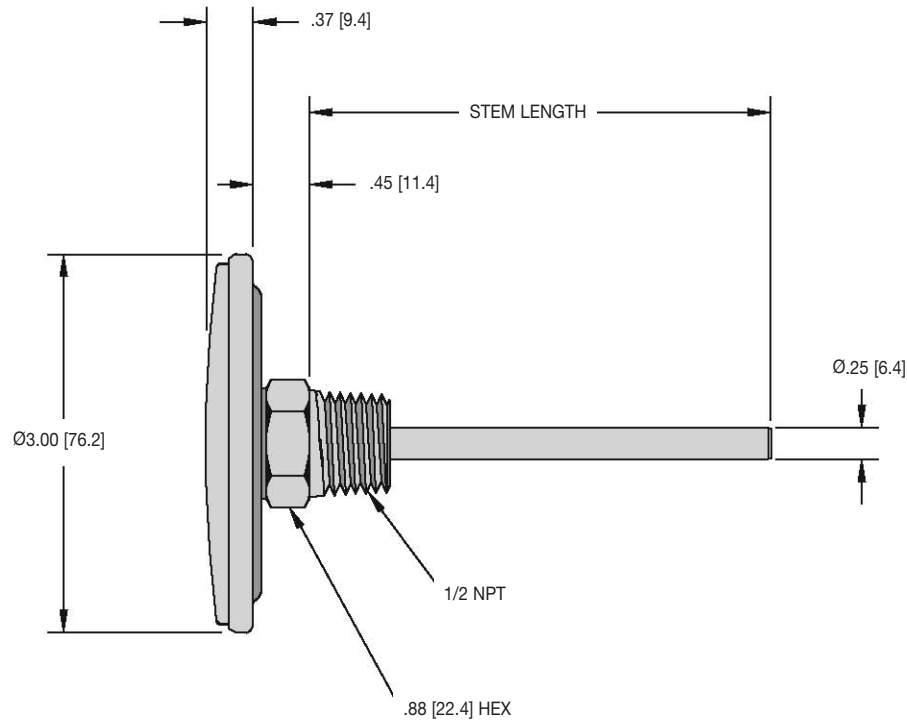

## Standard Ranges

Dual Scale (Fahrenheit & Celsius Range)		Fahrenheit Only Range		Celsius Only Range		Fahrenheit		Celsius	
Range Code	Range	Range Code	Range	Range Code	Range	Figure Intervals	Minor Divisions	Figure Intervals	Minor Divisions
01	-100° to 100°F & -75° to 40°C	01F	-100° to 100°F	01C	-75° to 40°C	20°	2°	10°	1°
02	-40° to 160°F & -40° to 70°C	02F	-40° to 160°F	02C	-40° to 70°C	20°	2°	10°	1°
12*†	0° to 100°F & -20° to 40°C	12F*†	0° to 100°F	12C*†	-20° to 40°C	10°	1°	10°	1°
03	25° to 125°F & -5° to 50°C	03F	25° to 125°F	03C	-5° to 50°C	10°	1°	5°	1/2°
04	0° to 200°F & -20° to 95°C	04F	0° to 200°F	04C	-20° to 95°C	20°	2°	10°	1°
05	20° to 240°F & -10° to 115°C	05F	20° to 240°F	05C	-10° to 115°C	20°	2°	10°	1°
27	0° to 250°F & -20° to 120°C	27F	0° to 250°F	27C	-20° to 120°C	50°	2°	20°	2°
06	50° to 300°F & 10° to 150°C	06F	50° to 300°F	06C	10° to 150°C	50°	2°	20°	2°
07	50° to 400°F & 10° to 200°C	07F	50° to 400°F	07C	10° to 200°C	50°	5°	50°	2°
08	50° to 500°F & 10° to 260°C	08F	50° to 500°F	08C	10° to 260°C	50°	5°	50°	2°

\* Minimum stem length for these ranges is 4".

† Minimum insertion length for these ranges is 3".