



Unique - One for All

Unique Mixproof Valve

Concept

The exceptional concept of this mixproof valve is characterized by excellent unmatched flexibility - yet still being very simple. The reliable modular design gives you the perfect valve for your exact needs in all mixproof operations with two different products flowing through one valve. Unique fits to your process!

The unique quality of this mixproof valve is the system of combining specific features and functions from a great variety of options offered. It is exceptional to the world of mixproof valves, yet providing minimal service and maintenance.

Working Principle

Unique is remote-controlled by means of compressed air. The valve is a normally closed (NC) valve.

The valve has two independent plug seals, forming a leakage chamber between them under atmospheric pressure during every working condition. In case of rare accidental leaking of product, this will flow into the leakage chamber and be discharged through the leakage outlet. When the valve is open, the leakage chamber is closed. The product can then flow from one line to the other.

The valve can be cleaned and water hammer protected to any level according to the needs in the specific process (see fig. 2). There is virtually no spillage of product when operating the valve.

SpiralClean

The Unique concept offers the Alfa Laval SpiralClean system to clean the upper and lower balanced plugs and leakage chamber, helping to meet the high hygienic standards of the sanitary flow industry. The system cleans more efficiently, uses less cleaning fluid by ensuring that a directional flow of CIP fluid reaches all the surfaces in much less time than with conventional systems. All external CIP systems for Unique includes the SpiralClean design as standard. Another benefit from the SpiralClean system is that it allows the Unique Mixproof valve to run under aseptic-like conditions. If you apply steam to the CIP pipes, this will form a steam barrier to the atmosphere.

Options

The concept of Unique is centering round the customer's needs and provides modern tailor-made solutions which are secured for the future. The customer gets exactly what he needs and only that. Only Alfa Laval offers the possibility of not choosing unnecessary features and functions, thus avoiding problems caused by a non-adapted product. The Unique Mixproof Valve is designed with user flexibility in mind. The customer can choose additional options as required individually; for example higher hygiene demands or higher resistance against physically tough conditions. Please see fig. 2 next page for a graphic overview of the modularity of this Unique Mixproof Valve.



Unique Mixproof Valve with ThinkTop®.

The drawing below gives an overview of all options when choosing the valve to fit your process, thus demonstrating the actual flexibility of the Unique Mixproof Valve. You can either choose these directly or add additional features ensuring that the valve suits your specific needs.

The Unique concept offers balanced and unbalanced plugs, seat lift, CIP for the plugs and leakage chambers and any combination in between.

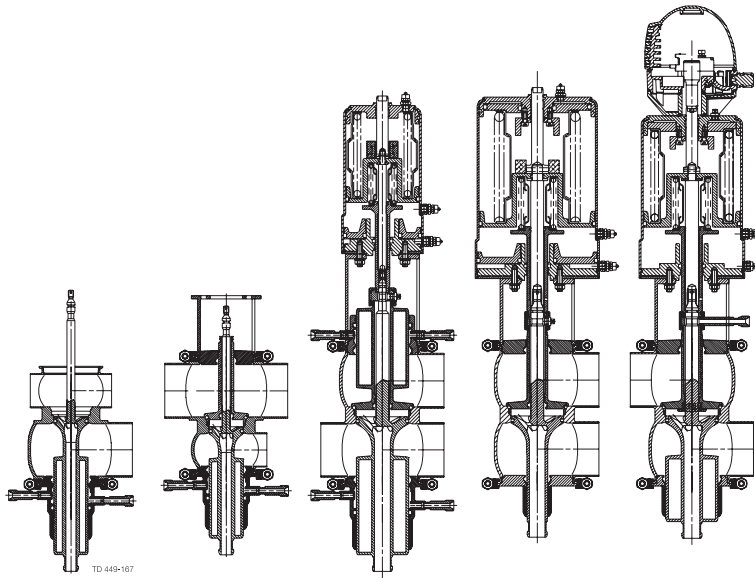

Size flexibility

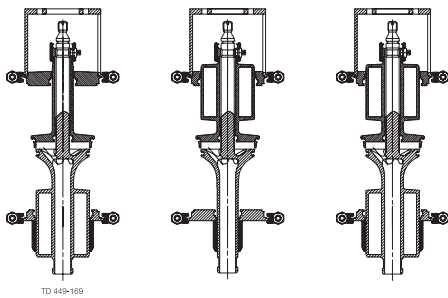

Balancing flexibility

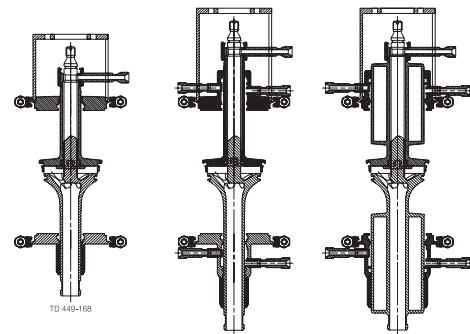

Hygienic flexibility

Fig. 2. Maximum flexibility option sheet.

Flexible Design Features

- Excellent flexibility - though simple.
- Adaption to all working conditions by combining components.
- Logically structured maintenance and valve assembly.
- Adaption and/or up-/downgrading on site.
 - a. Easy trouble-shooting.
 - b. Secured for future changes in working conditions.

Selection guide

To assist you in the selection we have included some standard configurations:

- Unique Basic
- Unique SeatClean
- Unique HighClean
- Unique UltraClean

You can either choose these directly or add additional features ensuring that the valve suits your specific needs.

Unique Basic has the basic components, providing significant safety and leakage detection.

- Actuator without seatlift.
- Unbalanced plugs.
- No SpiralClean of leakage chamber or plugs.

Unique SeatClean meets the typical demands of a process valve in the food and drink industry. It is also suitable for products with solids. Cleaning of the plugs and seats are performed by means of seatlift during normal cleaning procedure. This valve also includes a balanced lower plug that eliminates the risk of mixing products by pressure shock or when the pressure in the pipe is high. Its features are:

- Actuator with seat lift integrated.
- Balanced lower plug, Unbalanced upper plug.
- No SpiralClean of leakage chamber or plugs.

Unique SeatClean is the choice for standard solutions.

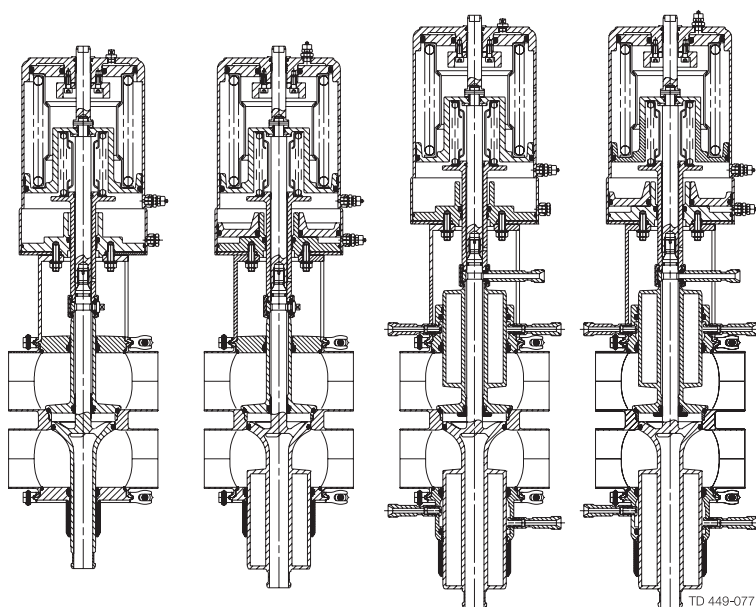

1. Unique Basic
2. Unique SeatClean
3. Unique HighClean
4. Unique UltraClean

Unique HighClean is sure to meet your processing needs when dealing with sticky products or if no recontamination can be accepted at all, as the valve can be provided with SpiralClean both around spindles and in leakage chamber. The valve is characterized by:

- Actuator without seatlift integrated.
- Balanced lower and upper plug.
- SpiralClean of leakage chamber as well as of upper and lower plug.

With balanced plugs, the configuration of this valve protects against high pressure and water hammer effect.

Unique UltraClean meets the highest demands for hygienic processing. It has:

- Actuator with seat lift integrated.
- Balanced lower and upper plug.
- SpiralClean of leakage chamber, upper and lower plug.

During the cleaning process, the plugs are lifted independently to ensure cleaning of plugs and seats together with their corresponding pipe. At the same time or separately the leakage chamber and balanced plugs are cleaned with our SpiralClean system. The Unique UltraClean also protects against high pressure and water hammer effect. It has few product wetted seals and allows no product spillage during operation. The Unique UltraClean mixproof valve is the choice for solutions requiring the highest level of hygiene. The UltraClean is suitable for applications with sticky products, products with high content of solids or applications where "close to aseptic conditions" is wanted.

Technical Data

Max. product pressure: 1000 kPa (10 bar) (For higher pressure, please ask Alfa Laval)
 Min. product pressure: Full vacuum.
 Temperature range: -5°C to +125°C (Depending on rubber quality)
 Air pressure: Max. 800 kPa (8 bar).

Materials

Product wetted steel parts: Acid-resistant steel 1.4404 (316L).
 Other steel parts: Stainless steel 1.4301 (304).
 Product wetted parts: EPDM, HNBR, NBR or FPM.
 Other seals: CIP seals: EPDM.

Actuator seals: NBR.

Guide strips: PTFE

Surface finish - choose from the following: Internal/external Matt (blasted) Ra<1.6

Internal Bright (polished) Ra<0.8

Internal/external Bright (internal polished) Ra<0.8

Note! The Ra values are only for the internal surface.

Options

- For Control & Indication of both upper and lower seat lift as well as main movement, please refer to index in Product Catalogue.
- 3A (Sanitary Standard) labelling on request.

Actuator

Configurator Code (Ordering leaflet)						STD	STD/STD*
	2	3	4	5	6	Operating pressure for SeatClean, High Clean and Ultra Clean at 6 bar air pressure	Operating pressure for Basic at 6 bar air pressure
Actuator Type	3	4BS ¹	4SS ²	5BS	5SS		
Actuator dimensions øD x L	120 x 230	157 x 252	186 x 281	186 x 281	186 x 379		
Connection Size ISO (DN/OD) DIN (DN) Sch.5							
38 40	STD	OP				1000 kPa	600 kPa
51 50 2"	STD	OP	OP			1000 kPa	600 kPa
63.5 65	OP	STD	STD*	OP	OP	1000 kPa	600 kPa
76.1 80 3"	OP	STD	STD*	OP	OP	1000 kPa	600 kPa
101.6 100 4"		OP	OP	STD	STD*	1000 kPa	600 kPa
125 5"		OP	OP	STD	STD*	800 kPa	600 kPa

STD: Normal size of actuator

STD*: Normal size actuator if lower plug is UNBALANCED

OP: Alternative size of actuator (NB: For choice and performance of optional actuators please contact Alfa Laval or refer to the CAS Configurator).

1 BS = Basic spring

2 SS = Strong spring

Radial Seat Diameter

ISO (DN/OD)	DIN (DN)	Sch. 5	Seat
38	40		Ø53.3
51	50	2"	Ø53.3
63.5	65		Ø81.3
76.1	80	3"	Ø81.3
101.6	100	4"	Ø100.3
	125	5"	Ø115.3
	150	6"	Ø115.3

Pressure drop/capacity diagrams

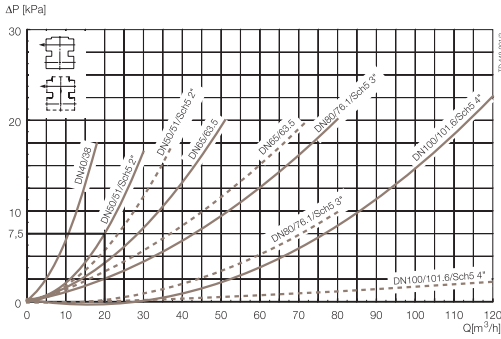

Fig. 3. Pressure drop/capacity diagram, upper body.
Full lines: Balanced upper plug.
Dotted lines: Unbalanced upper plug.

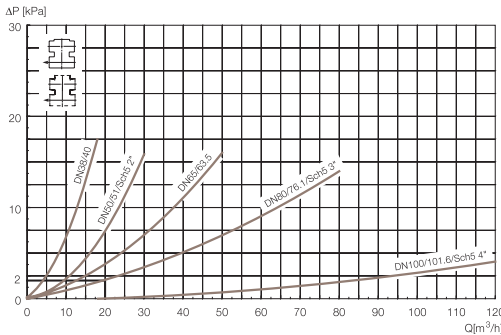

Fig. 4. Pressure drop/capacity diagram, lower body, balanced and unbalanced lower plugs.

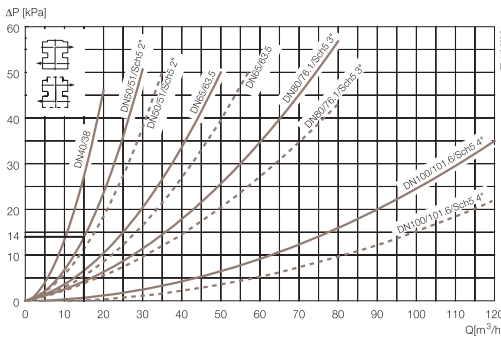

Fig. 5. Pressure drop/capacity diagram, between bodies.
Full lines: Balanced.
Dotted lines: Unbalanced.

Note! For the diagrams the following applies:

- Medium: Water (20°C).
- Measurement: In accordance with VDI 2173.

Example to determine pressure drop:

- Upper body size: DN/OD 51mm. Balanced upper plug. Capacity = 20 m³/h.
- Lower body size: DN/OD 76.1mm. Balanced lower plug. Capacity = 20 m³/h.
- Between bodies: Capacity = 15 m³/h

Result:

From fig. 3, $\Delta p = 7.5$ kPa through upper body.

From fig. 4, $\Delta p = 2$ kPa through lower body.

From fig. 5, $\Delta p = 14$ kPa seeing that:

- The smallest body determines the curve for Δp between bodies.
- Always choose the curve for balanced plugs if upper plug is balanced. If only lower plug is balanced, always choose the curve for unbalanced.

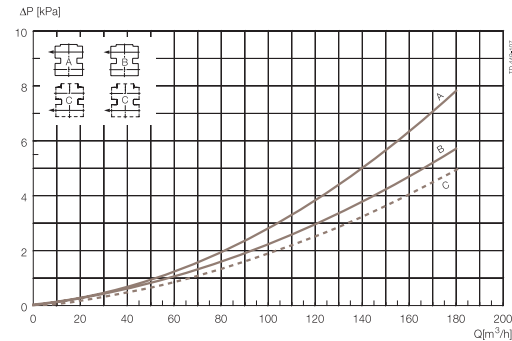

Fig.6 Pressure drop/capacity diagram, through bodies DN 125, DN 150,
Sch. 5 5", Sch. 5 6".
A: Balanced upper plug
B: Unbalanced upper plug
C: Balanced and unbalanced lower plug.

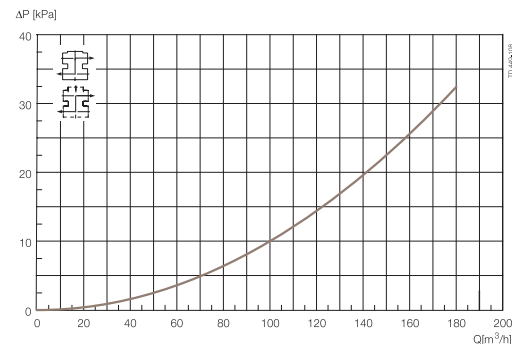

Fig.7 Pressure drop/capacity diagram between bodies.
Balanced and unbalanced plugs, DN 125, DN 150, Sch. 5 5",
Sch. 5 6".

Dimensions (mm)

Size ISO/DIN/Sch.5	DN/OD					DN							Sch. 5					
	38	51	63.5	76.1	101.6	40	50	65	80	100	125	150	2"	3"	4"	5"	6"	
*A																		
Basic Clean	530	575	699	699	899	530	575	699	699	899	993	993	530	699	889	993	993	
Seat Clean	530	575	670	670	791	530	575	670	670	791	895	895	530	670	791	895	895	
*A																		
HighClean + UltraClean	611	656	760	760	922	611	656	760	760	922	1026	1026	656	760	922	1026	1026	
B	170	220	220	220	300	170	220	220	220	300	300	300	220	220	300	300	300	
**C	60.8	73.8	86.3	98.9	123.6	64	76	92	107	126	151	176	83	110.7	136.1	161.76	188.76	
OD	38	51	63.5	76.1	101.6	41	53	70	85	104	129	154	60.3	88.9	114.3	141.3	168.3	
ID	34.8	47.8	60.3	72.9	97.6	38	50	66	81	100	125	150	57	84.68	110.08	135.76	162.76	
t	1.6	1.6	1.6	1.6	2.0	1.5	1.5	2.0	2.0	2.0	2.0	2.0	1.65	2.11	2.11	2.77	2.77	
E																		
Basic/Seat Clean	100	121	149	142	177	99	119	146	138	176	215	202.5	116	136	171	210	196	
E																		
High Clean/Ultra Clean	144	165	200	193	248	143	163	197	189	247	286	273.5	160	187	242	280.5	267	
F1	31.5	31.5	38	38	59	31.5	31.5	38	38	59	59	59	31.5	38	59	59	59	
F2	5	5	5	5	5	5	5	5	5	5	5	5	5	5	5	5	5	
øD Basic	120	120	186	186	186	120	120	186	186	186	186	186	120	186	186	186	186	
øD Seat Clean, High Clean and Ultra Clean	120	120	157	157	186	120	120	157	157	186	186	186	120	157	186	186	186	
L Basic	230	230	281	281	379	230	230	281	281	379	379	379	230	281	379	379	379	
L Seat Clean, High Clean and Ultra Clean	230	230	252	252	281	230	230	252	252	281	281	281	230	252	281	281	281	
M/ISO clamp	21	21	21	21	21													
M/DIN clamp						21	21	21	21	21	28	28						
M/ISO male	21	21	21	21	21													
M/DIN male						22	23	25	25	30	46	50						
M/SMS male	20	20	24	24	35													
M/BS male	22	22	22	22	27													
Weight (kg) Basic	13.5	15	24	24	34	13.5	15	24	24	34	44	45	15	24	24	44	45	
Weight (kg) SeatClean	13.5	15	24	24	34	13.5	15	24	24	34	47	48	15	24	34	47	48	
Weight (kg) High-/UltraClean	14.5	16	27	27	38	14.5	16	27	27	38	51	52	16	27	38	51	52	

TD900-074-1

Note!

* For the A-measure if different upper/lower body sizes, please refer to CAS configurator or contact Alfa Laval.

** The measure C can always be calculated by the formula $C = \frac{1}{2}ID_{upper} + \frac{1}{2}ID_{lower} + 26$ mm.

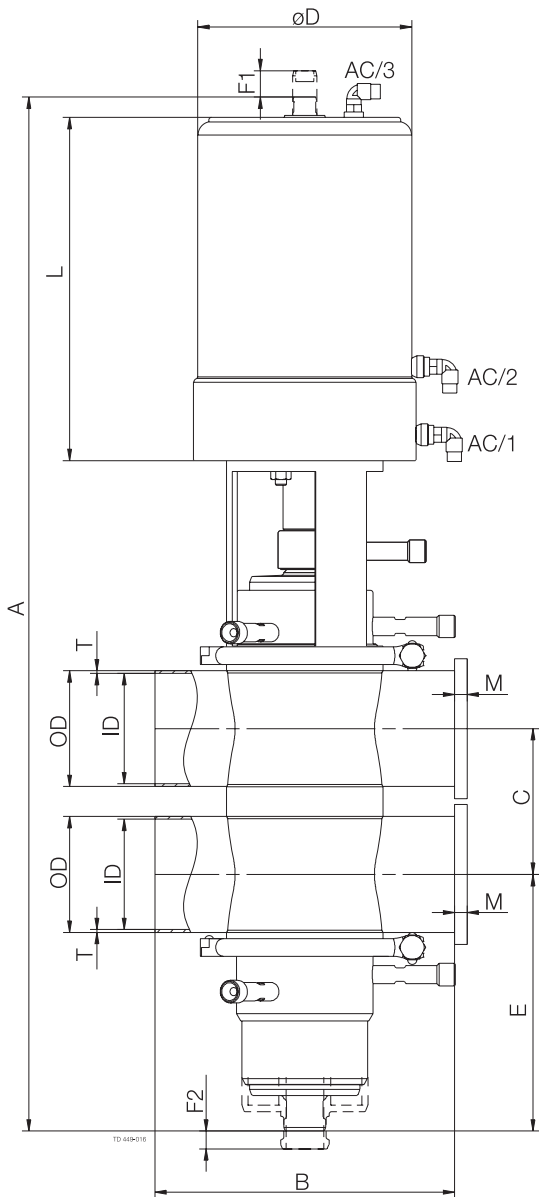
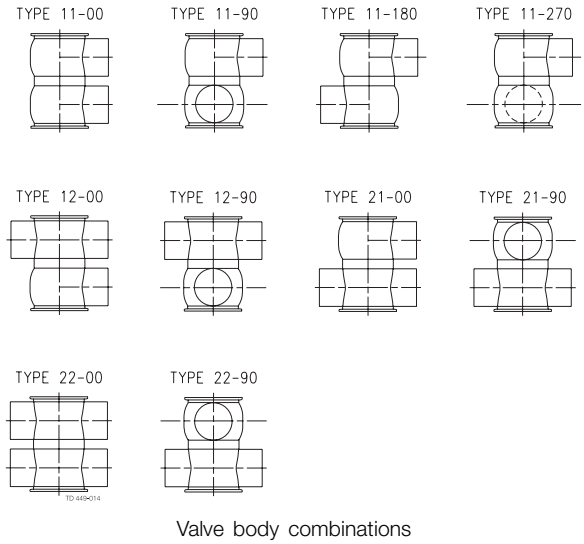

Fig. 8. Details of Unique Mixproof Valve.

Note for mixed bodies:

1. The seat always applies to the smallest valve body.
2. Dimension B is equal with the largest valve body size.



Example: Type 11-00

Type	
1	Number of ports - lower valve body
1	Number of ports - upper valve body
00	Angle between ports

Size ISO/DIN/Sch.5	DN/OD					DN							Sch. 5				
	38	51	63.5	76.1	101.6	40	50	65	80	100	125	150	2"	3"	4"	5"	6"
Kv-value Upper Seat-lift [m ³ /h]	1.5	1.5	2.5	2.5	3.1	1.5	1.5	2.5	2.5	3.1	3.7	3.7	1.5	2.5	3.1	3.7	3.7
Kv-value Lower Seat-lift [m ³ /h]	0.9	0.9	1.9	1.9	2.5	0.9	0.9	1.9	1.9	2.5	3.1	3.1	0.9	1.9	2.5	3.1	3.1
Air consumption Upper Seat-lift * [n litre]	0.2	0.2	0.4	0.4	0.62	0.2	0.2	0.4	0.4	0.62	0.62	0.62	0.2	0.4	0.62	0.62	0.62
Air consumption Lower Seat-lift * [n litre]	1.1	1.1	0.13	0.13	0.21	1.1	1.1	0.13	0.13	0.21	0.21	0.21	1.1	0.13	0.21	0.21	0.21
Air consumption Main Movement * [n litre]	0.86	0.86	1.63	1.63	2.79	0.86	0.86	1.62	1.62	2.79	2.79	2.79	0.86	1.63	2.79	2.79	2.79
Kv-value SpiralClean Spindle CIP [m ³ /h]	0.12	0.12	0.12	0.12	0.12	0.12	0.12	0.12	0.12	0.12	0.12	0.12	0.12	0.12	0.12	0.12	0.12
Kv-value SpiralClean External CIP of leakage chamber [m ³ /h]	0.25	0.25	0.29	0.29	0.29	0.25	0.25	0.29	0.29	0.29	0.29	0.29	0.25	0.29	0.29	0.29	0.29

TD900-074-1

Note:

* [n litre] = volume at atmospheric pressure

Recommended min. pressure for SpiralClean: 2 bar.

Formula to estimate CIP flow during seat lift:

(for liquids with comparable viscosity and density to water):

$$Q = K_v \cdot \sqrt{\Delta p}$$

$$Q = \text{CIP - flow (m}^3\text{/h)}.$$

K_v = K_v value from the above table.

Δp = CIP pressure (bar).

Ordering

For ordering, either refer to CAS configurator or see ordering leaflet that contains both article numbers for the four standard valves and a manual configurator.

This product has EHEDG certification

ESE00279EN 0701

The information contained herein is correct at the time of issue, but may be subject to change without prior notice.

How to contact Alfa Laval

Contact details for all countries are continually updated on our website. Please visit www.alfalaval.com to access the information direct.