

TOP LINE

PROCESS EQUIPMENT COMPANY

Top-Flo[®]

Automated Flow Control Valves



Manufactured by:
Group Defontaine
Saint Herblain Cedex, France



www.toplineonline.com

DCX3 Shut Off Valves, DCX4 Divert Valves and and VDCI Mix Proof Valves



Summary

Shut Off and Divert Valves

Body Designs, Characteristics	1
Performance Curves, Dimensions	2-3
Aseptic Shut Off Valves	3
Manual Shut Off and Divert Valves	4
DCX3 Regulating Valve	5
Tank Bottom Valves, Performance	
Curves, Dimensions	6
Small Size Shut Off and Divert Valves,	
Performance Curves, Dimensions	7
Mix Proof Valves - VDCI	8
Performance Curves	9
Dimensions	10
Operation, Use of Break Away	
Actuators	11
Detailed Drawing of Mix Proof	
Valve - VDCI	12
Variations - Mix Proof Valves - VDCI	
VDCI - PMO Mix Proof Valve	13
Tank Bottom Mix Proof Valve	14
Tank Bottom - Dimensions	15
Position Feedback Equipment	
Equipment Selection Matrix	16-17

DCX3 - DCX4 shut off and divert valves

General Characteristics

- High tech and sturdy air operated valve, with a floating plug seal, meeting stringent use criteria.
- An extra thick body of the actuator and of the valve, ensuring a good resistance to mechanical and thermal distortions.
- A modular design enabling the following configurations:
 - Shut off valve
 - DCX3 L
 - DCX3 T
 - DCX3 X
 - Divert valve
 - DCX4 L/L
 - DCX4 T/L
 - DCX4 L/T
 - DCX4 L/X
- PFA seals quality ensures a complete sealing at high temperature and a good resistance to aggressive products.
- Plastomer seal can be replaced by elastomer seal
- Single or double acting connection
- With plastomer seal, vertical setting up (especially for DCX4)

Dimensions

1" - 1-1/2" - 2" - 2-1/2" - 3" - 4" - 5" - 6"

Material

- Body: 316L stainless steel
- Shut-off unit: 316L stainless steel
- Manual or automatic operating devices: 304 stainless steel
- Plug seal: PFA and elastomer
- Stem seal: viton, EPDM, silicone

Options

- Signal back equipment on the top of the actuator
- Sterilization of the stem through an upper guide bearing

Variants

- Plug and body machined for a metal to metal sealing (without seal)
- Elastomer sealing (specific plug with viton, EPDM o-ring)
- Manual operator device (instead of the actuator)
- Tank bottom type
- Long stroke valve available upon request

Surface Finish

- External = 47 RA max (150 grit)
- Internal = 32 RA max (180 grit)
- Upgraded finishes upon request

Various body designs

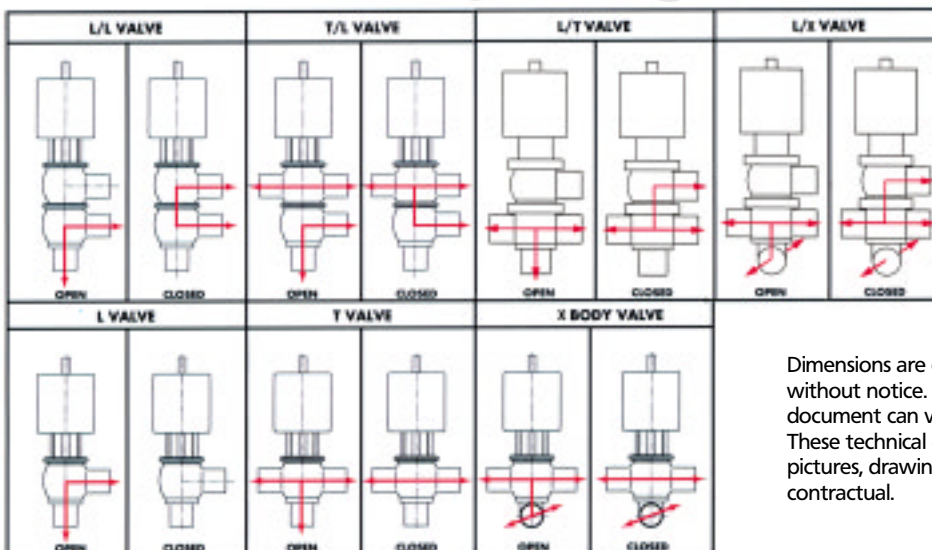

Dimensions are given as information. Subject to change without notice. Technical data mentioned on this document can vary according to technical changes. These technical data are an accurate information, but pictures, drawings, sketches of this document are not contractual.

Performance curve for DCX3 - DCX4 shut off and divert valves

Working conditions

The working conditions are established for valve normally closed (NC), normally open (NO), or double acting.

SIZE	1" to 2-1/2"	3"	4"	6"
Maximum pressure under the plug at 68° F	87 psi	87 psi	87 psi	87 psi

Pressure drop DCX3/DCX4 changeover valves 1" to 2"

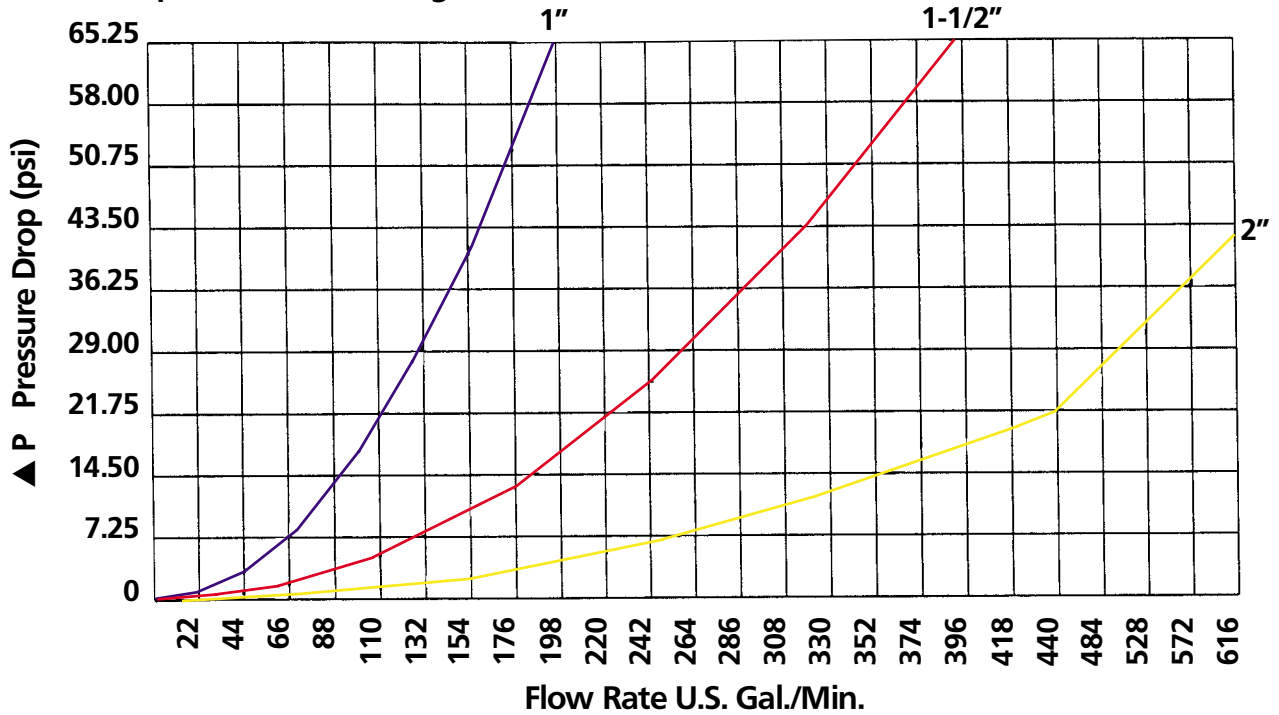

Pressure drop DCX3/DCX4 changeover valves 2-1/2" to 6"

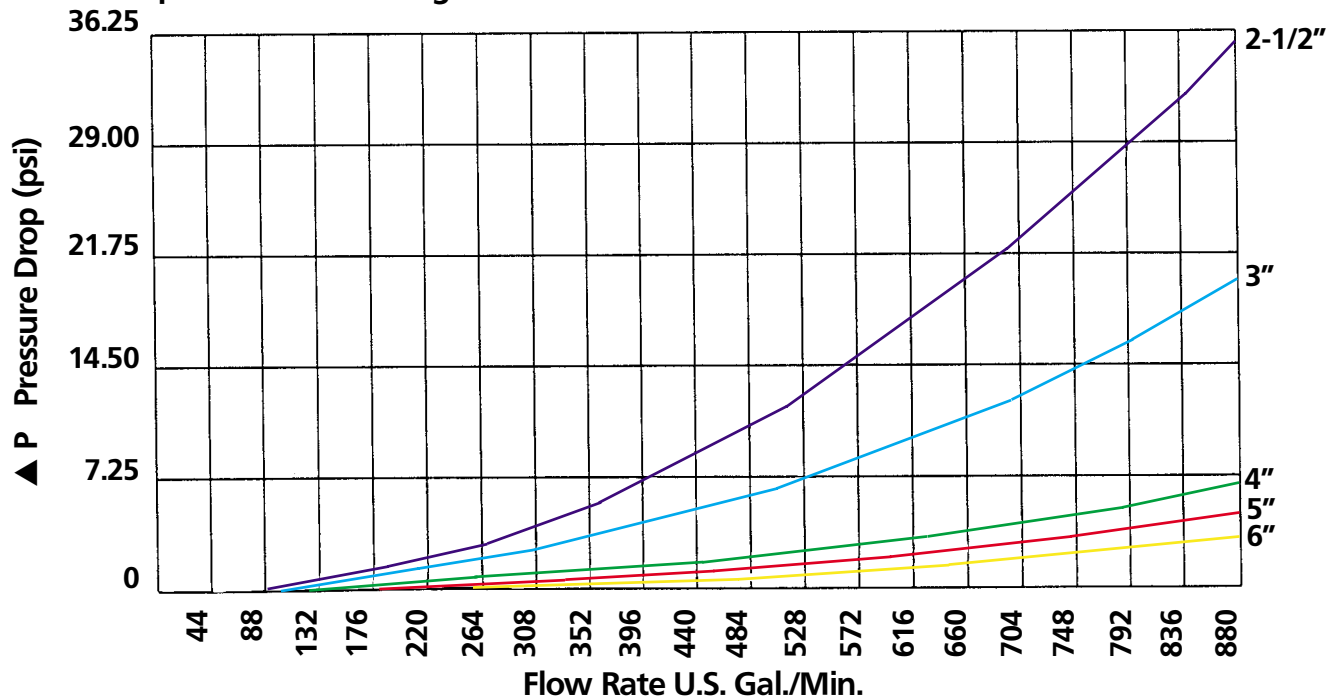

Air supply of the actuator
65 to 116 psi (filtered dry air)

Permissible maximum temperature
285° F

Vacuum resistance (absolute pressure)
5.8 psi or 12 inches of Hg

Test
Valves meet the requirements of the ISO 5208 norm.

Dimensions

DCX3

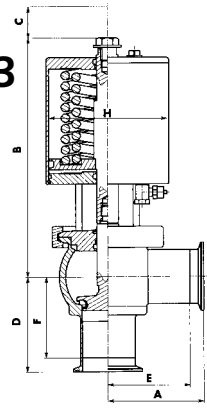

SIZE	A	B	C	D	E	F	H	WEIGHT (LBS.)
1"	2-1/2"	7-5/8"	11/16"	2-1/2"	2"	2"	3-1/4"	8.90
1-1/2"	2-3/4"	7-3/4"	13/16"	2-3/4"	2-1/4"	2-1/4"	3-1/4"	8.90
2"	3-1/2"	8-7/8"	1-3/16"	3-1/2"	3"	3"	4-5/16"	15.50
2-1/2"	3-1/2"	10-7/8"	1-3/8"	3-1/2"	3"	3"	6-5/16"	35.30
3"	3-3/4"	11-1/8"	1-3/8"	3-3/4"	3-1/4"	3-1/4"	6-5/16"	35.30
4"	5-3/4"	13-1/4"	1-9/16"	5-3/4"	5-1/8"	5-1/8"	8-1/8"	61.70
6"	7-13/16"	19-11/16"	4-21/64"	7-13/16"	7-1/16"	7-1/16"	10-5/8"	143.30

DCX4

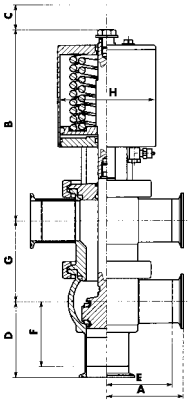

SIZE	A	B	C	D	E	F	G	WEIGHT (LBS.)
1"	2-1/2"	7-5/8"	9/16"	2-1/2"	2"	2"	3-1/4"	11.00
1-1/2"	2-3/4"	7-3/4"	11/16"	2-3/4"	2-1/4"	2-1/4"	3-1/4"	11.00
2"	3-1/2"	8-7/8"	1-1/16"	3-1/2"	3"	3"	3-3/4"	19.90
2-1/2"	3-1/2"	10-7/8"	1-1/4"	3-1/2"	3"	3"	4-1/4"	44.10
3"	3-3/4"	11-1/8"	1-1/4"	3-3/4"	3-1/4"	3-1/4"	4-3/4"	46.30
4"	5-3/4"	13-1/4"	1-7/16"	5-3/4"	5-1/8"	5-1/8"	6-1/2"	88.20
6"	7-13/16"	19-11/16"	4-21/64"	7-13/16"	7-1/16"	7-1/16"	7-1/16"	172.00

DCX3A - DCX4A Aseptic shut off/divert valves

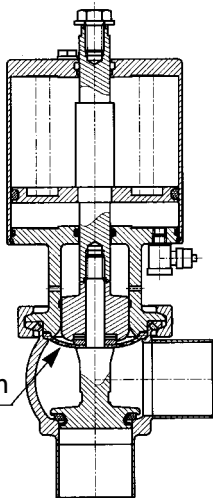

General characteristics

This valve has been designed to complete the range of the DCX3 shut off valve. The valve uses the same partial assemblies (actuator and valve body). An additional PTFE diaphragm on the upper part of the body allows to isolate completely the external components. Therefore, the parts, which are directly in contact with the fluid are:

- The body in 316L stainless steel, its sturdy construction and the wall surface finish allow an efficient sterilization at high temperature.
- The plug with the same floating PFA seal (from the technical point of view) as the VDCI valve, allows a perfect cleaning of the valve.
- The diaphragm made of PTFE plastomer is held tightly in place by a compressed top plate.
- Option: Plug and body machined, for a metal to metal sealing (without seal).
- For DCX4 sterilization of the stem through an upper guide bearing.

General characteristics

The maximum working pressure is 101 psi at 68° F.

Permissible maximum temperature

The valve accepts a sterilization temperature of 285°F, valve open, without operating the actuator.

Dimensions

Refer to the dimensions of DCX3 shut off valve or DCX4 divert valve

Manual shut off and divert valves

General characteristics

The manual operator device is adaptable for DCX3 and DCX4 shut off and divert valves, in place of the pneumatic actuator. This device uses standard body, plug and shut-off unit.

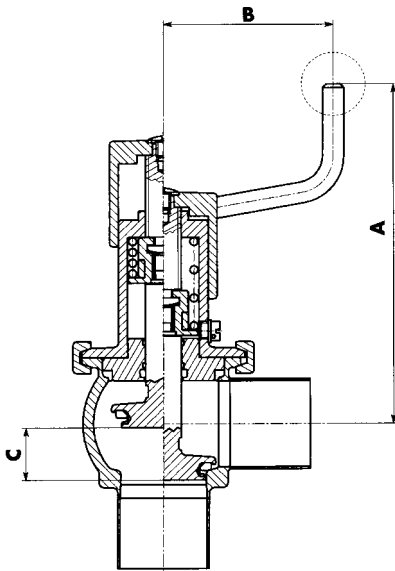

DCX3 Manual Shut Off Valve

SIZE	A	B	C	WEIGHT (LBS.)
1"	7-1/16"	3-3/4"	11/16"	6.6
1-1/2"	7-5/16"	3-3/4"	7/8"	6.6
2"	7-5/8"	3-3/4"	1-3/16"	8.8
2-1/2"	8-1/8"	3-3/4"	1-3/8"	13.3
3"	8-3/8"	3-3/4"	1-3/8"	13.3
4"	9-9/16"	3-3/4"	1-9/16"	28.7

Manual DCX3

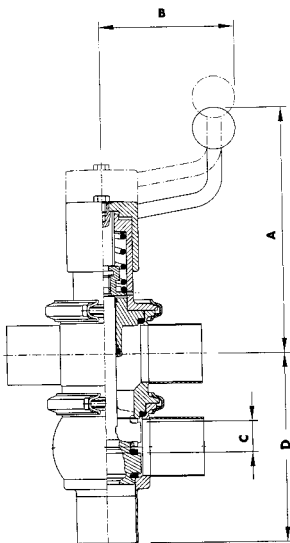

DCX4 Manual Divert Valve

SIZE	A	B	C	D	WEIGHT (LBS.)
1"	7-13/16"	3-3/4"	9/16"	5-1/4"	8.8
1-1/2"	7-7/8"	3-3/4"	11/16"	5-1/2"	11.1
2"	8-3/16"	3-3/4"	1-1/16"	6-3/4"	13.3
2-1/2"	8-15/16"	3-3/4"	1-17/64"	7-1/4"	22.1
3"	8-15/16"	3-3/4"	1-17/64"	8"	22.1
4"	10-3/16"	3-3/4"	1-3/8"	11-5/8"	59.6

Manual DCX4

DCX3 regulating valve



General characteristics

Based on the technology of the standard DCX3 valve, a food-grade regulating valve was developed. The DCX3 regulating valve is standard equipped with a 316L stainless steel parabolic type plug. Combined with the Burkert 1067 positioner, this valve has the capability to regulate: flow rate, pressure, or level of any fluid in food processing. The Burkert 1067 positioner will accept a 4-20 mA or 0-10 VDC signal for integral control from sensors or PLC's. The main electronic controls (PID regulator, electro-pneumatic controller) are housed in a Nema 4 enclosure and the instant plug position gauge is mounted directly on the valve actuator. The parabolic type plug does not create a 100% tight seal within the valve, and is not meant for complete shut off of the valve. As an option, a metal-to-metal seal can be produced for a 100% tight seal. The DCX3 regulating valve is available in sizes 1" to 3". 4" size upon request.

Advantages

- Compact unit
- 316L stainless steel body and plug
- 304 stainless steel actuator
- Easy to program electronic functions

Options

- Clamp, weld, or I-line connections
- Upgraded ID finish

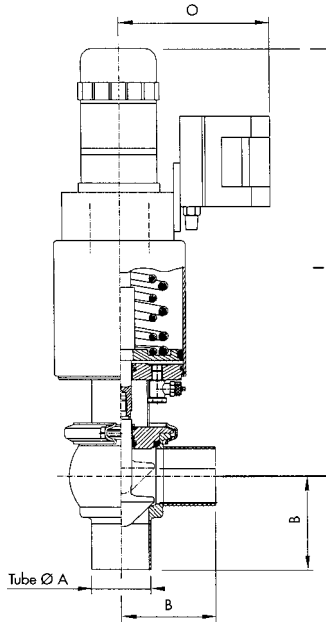
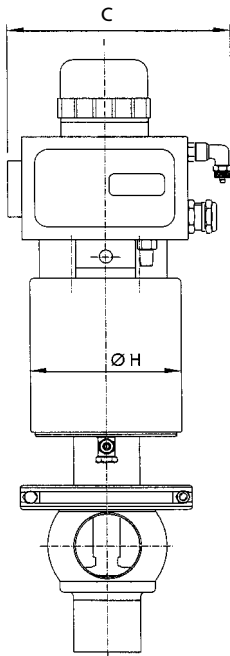

Flow Characteristics

% OPENING OF VALVE	1"	1-1/2"	2"	2-1/2"	3"	4"
10	5.00	5.00	16.71	17.25	19.85	28.78
20	7.38	9.57	28.00	29.94	35.90	53.85
30	9.38	14.71	37.42	42.25	54.21	83.54
40	11.42	20.43	48.15	56.23	71.45	110.74
50	13.76	25.92	57.12	68.56	89.98	143.96
60	15.74	31.50	66.32	81.54	108.12	175.15
70	18.06	36.07	72.48	95.23	125.75	203.71
80	19.46	40.71	81.24	107.46	143.21	234.86
90	21.59	44.93	88.18	120.65	162.32	269.45
100	24.34	49.30	95.29	132.25	181.25	305.81

 : Optimum operating point

Tank bottom shut off and divert valves

General Characteristics

- This valve has the same characteristics as the other shut off and divert valves, single or double acting (DCX3 or DCX4)
- Integral flange for welding to tank bottom
- Eliminates product retention area on tank bottom
- Single acting recommended for single sealing

Dimensions

1" - 1-1/2" - 2" - 2-1/2" - 3" - 4"

Material

- Body and plug: 316L stainless steel
- Plug seal: PFA
- Body seal: viton, EPDM, silicone
- Actuator: 304 stainless steel

Options

- Signal back equipment on the top of the actuator

Surface Finish

- External = RA max (150 grit)
- Internal = 32 RA max (180 grit)



Valve ends

- On tank: welded integral flange
- On tube: according to the norm, available with many different industry standards (SMS - DIN - CLAMP - tube, etc.)

Performances

Working conditions

The working conditions are established only for valve normal closed (NC).

SIZE	1" to 2-1/2"	3"	4"
Maximum pressure under the plug at 68° F	87 psi	87 psi	87 psi

Pressure drop

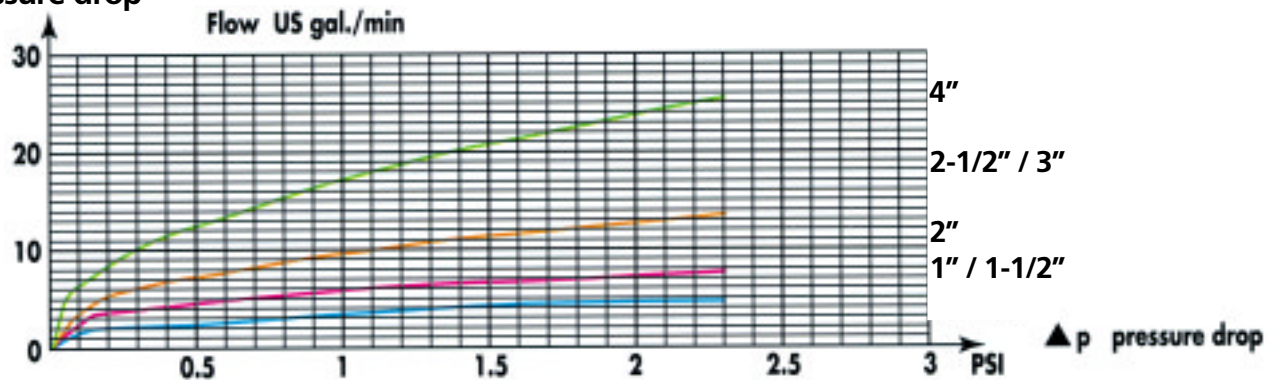

Air supply of the actuator

75 to 116 psi (filtered dry air)

Vacuum resistance (absolute pressure)

5.8 psi or 12 inches of Hg

Permissible maximum temperature

285° F

Test

Valves meet the requirements of the ISO 5208 norm.

Dimensions for tank bottom valves

SIZE	A	B	C	D	E	F	G
1"	2"	7-3/8"	1"	1-3/16"	5-1/2"	3/16"	3-1/4"
1-1/2"	2-1/4"	7-11/16"	1"	1-3/8"	5-1/2"	3/16"	3-1/4"
2"	3"	8-7/8"	1-3/16"	1-5/8"	5-1/2"	3/16"	4-5/16"
2-1/2"	3"	10-7/8"	1-3/8"	1-15/16"	7-7/16"	3/16"	6-5/16"
3"	3-1/4"	11-1/8"	1-3/8"	2-3/16"	7-7/16"	3/16"	6-5/16"
4"	5-1/8"	13-3/8"	1-9/16"	2-15/16"	9-13/16"	1/4"	8-1/8"

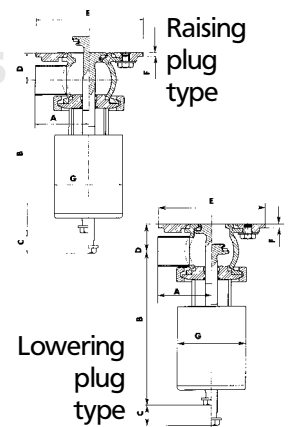

Small size shut off and divert valves

General Characteristics

- Compact body
- Heavy plug and body
- Easy disassembly

Dimensions

1/2" - 3/4" - 1"

Material

- Body: 316L stainless steel
- Plug: PFA
- Handle: PBT plastic material
- Actuator: 304 stainless steel

Valve ends

- Butt weld
- Clamp

Surface finish

- External = 47 RA max (150 grit)
- Internal = 32 RA max (180 grit)

Working conditions

- Temperature = 275°F
- Sealing pressure = 240 psi
- Air supply of the actuator = 75 to 116 psi (dry filtered air)

Operator devices

- Manual: Handle with a visual indicator for the opening of the valve
- Automated: Single or double acting pneumatic actuator

Pressure drop automated DCX3 small size changeover valve

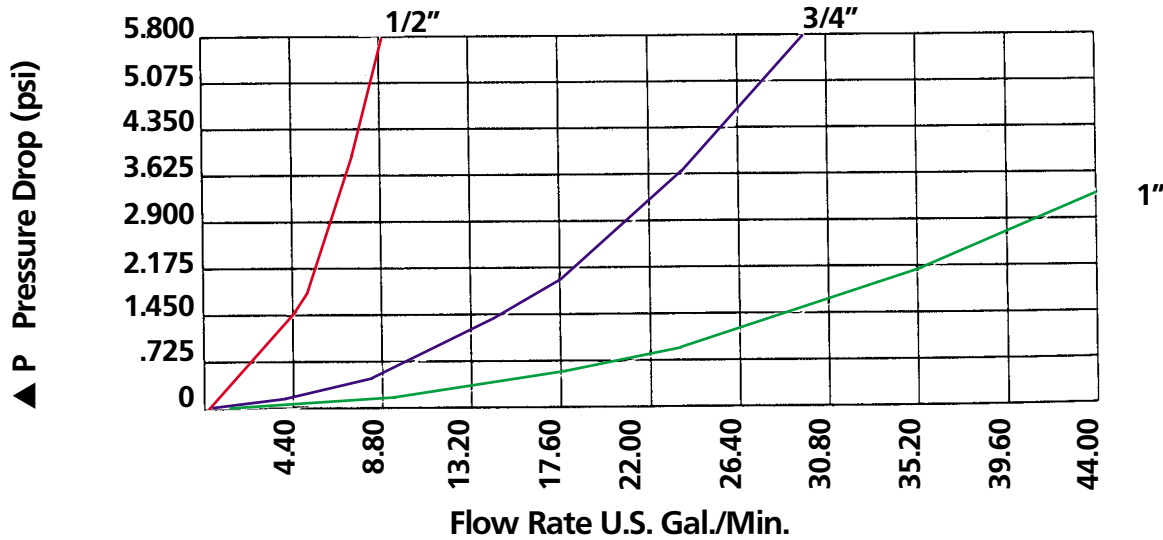

Dimensions

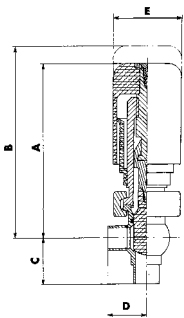

Manual valve

SIZE	A	B	C	D	E
1/2"	5-1/16"	5-1/2"	1-3/16"	1-1/8"	1-15/16"
3/4"	5-1/8"	5-9/16"	1-3/8"	1-3/16"	1-15/16"
1"	5-1/4"	5-13/16"	1-9/16"	1-7/16"	1-15/16"

SIZE	A	B	C	D	E
1/2"	6-3/4"	7-1/4"	1-3/16"	1-1/8"	2-3/8"
3/4"	6-3/4"	7-1/4"	1-3/8"	1-3/16"	2-3/8"
1"	7-3/8"	7-15/16"	1-9/16"	1-7/16"	2-13/16"

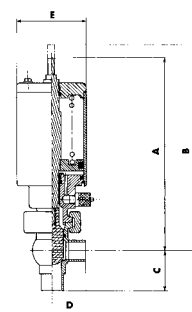

Air operated valve

Mix proof valve - VDCI

General Characteristics

- High tech, mix proof valve, with two independent plugs meeting stringent use criteria.
- Fitted with an extra thick body of the actuator and of the valve, ensuring a good resistance to mechanical and thermal distortions.
- Possibility to actuate the two plugs independently and to clean the chamber area, plugs closed, thanks to a double wall leak detection channel.
- Partial balancing of the pressure under the lower plug thanks to a protected counterbalance.
- PFA seals ensure a complete sealing at high temperature and a good resistance to aggressive products (easily cleaned).
- The design of the VDCI allows the releasing pressure outside without any risk of mixing between the two parts of the valve, in case of overpressure against 145 psi under the lower plug.

Dimensions

1-1/2" - 2" - 2-1/2" - 3" - 4" - 5" - 6"

Material

- Body: 316L stainless steel
- Shut-off unit: 316L stainless steel
- Actuator: 304 stainless steel
- Plug seal: PFA
- Stem seal: viton (according to FDA specifications)

Options

- Upper modular break away actuator to allow the lifting of the lower plug.
- Signal back equipment on the top of the actuator.
- Sterilization of the stem and of the counterbalance through upper and lower guide bearings, without changing the body.
- Tank bottom type.
- Proximity switches mounted onto the bracket.

Surface Finish

- External = 47 RA max (150 grit)
- Internal = 32 RA max (180 grit)

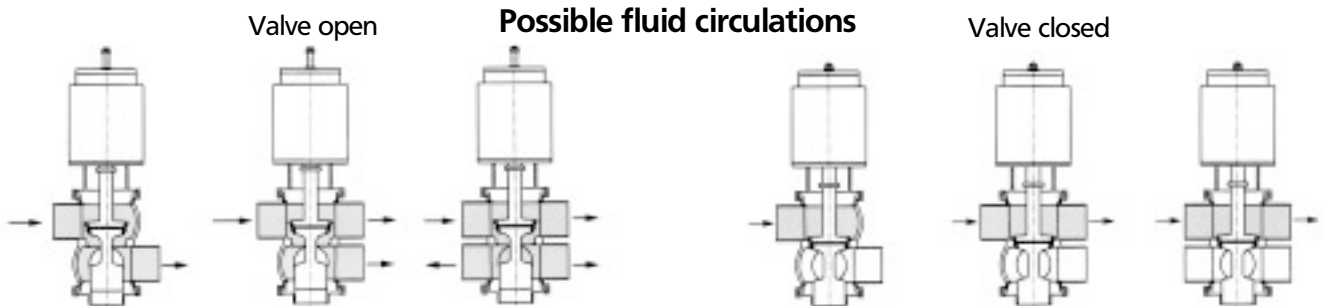

Various body designs

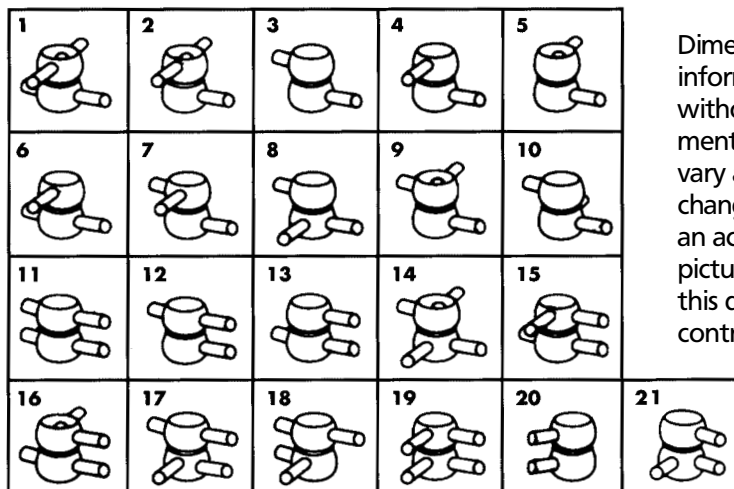

Dimensions are given as information. Subject to change without notice. Technical data mentioned on this document can vary according to technical changes. These technical data are an accurate information, but pictures, drawings, sketches of this document are not contractual.



Performances for VDCI mix proof valve

Working conditions

Maximum cleaning is dependent on the lifting stroke of the plugs and varies according to the different diameters. The below sheet indicates the flows calculated according to the tests realized by the CETIM (French Laboratory) under a pressure of 116 psi. Min. / Max. flow range under a water pressure of 116 psi.

Size	Cleaning flow by lifting of the upper plug in ft ³ /h	Cleaning flow by lifting of the lower plug in ft ³ /h
1-1/2" - 2"	35 - 141	35 - 88
2-1/2" - 3"	53 - 176	35 - 141
4"	71 - 212	53 - 176
5" - 6"	176 - 282	71 - 212

Air supply of the actuator

Filtered dry air from 75 psi min. to 120 psi max. through Rilsan hose DN 1/4" OD x 1/8" ID (5/16" OD x 3/16" ID)

Fluid working pressure

120 psi under the plug, before releasing (whatever the way of the flow is)

Permissible maximum temperature

285°F (difference of temperature between the upper and the lower line: max. 195°F)

Vacuum resistance (absolute pressure)

5.8 psi or 12 inches of Hg

Test

Valves meet the requirements of the ISO 5208 norm.

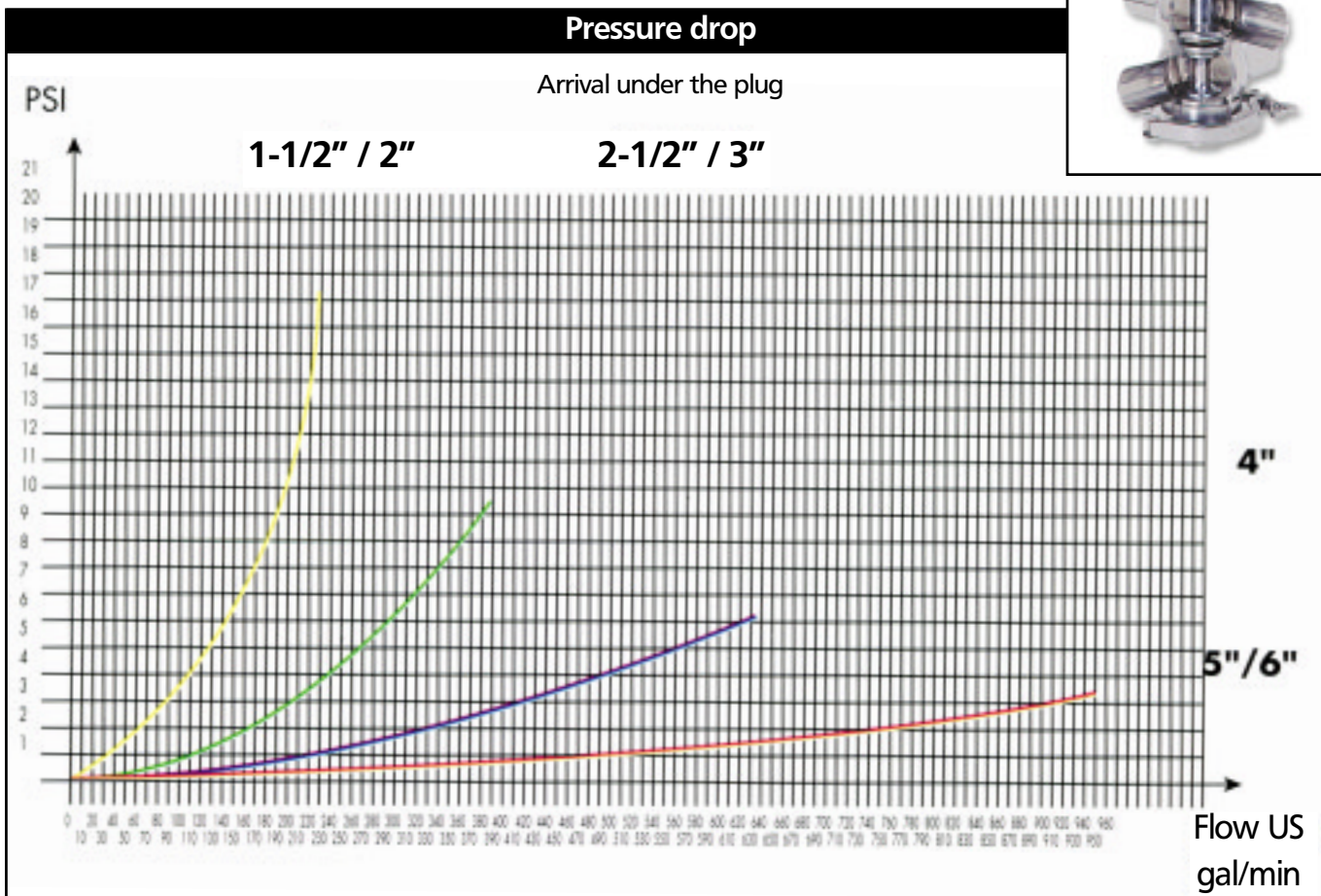

Dimensions for VDCI mix proof valve

10

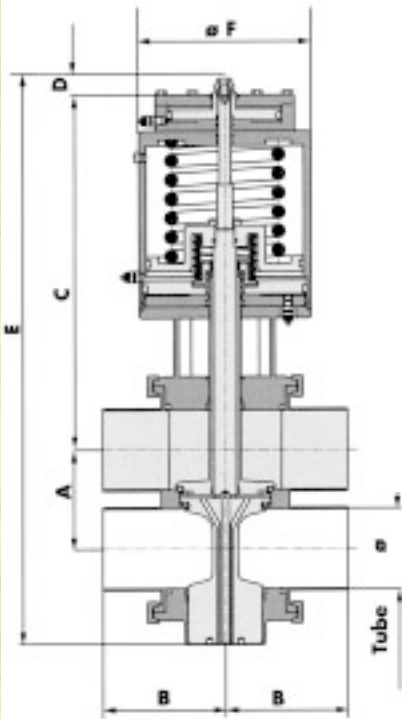

SIZE	A	B	C	D	E	F	WT. LB.
1-1/2"	2-3/16"	4-1/8"	12-13/16"	1-5/8"	19-7/8"	5-3/16"	49
2"	2-3/4"	4-1/8"	13-13/16"	1-5/8"	20-15/16"	5-3/16"	49
2-1/2"	3-3/8"	5-1/8"	14-9/16"	1-15/16"	24-3/16"	6-5/8"	84
3"	3-3/4"	5-1/8"	14-15/16"	1-15/16"	25-3/16"	6-5/8"	84
4"	4-15/16"	6-1/8"	17-1/2"	2-3/16"	29-1/2"	8-5/8"	165
5"	6-1/8"	7-7/8"	20-7/8"	2-3/8"	35-7/16"	10-3/4"	298
6"	7-1/8"	7-7/8"	21-5/8"	2-3/8"	37-5/8"	10-3/4"	298

Operation for VDCI mix proof valves

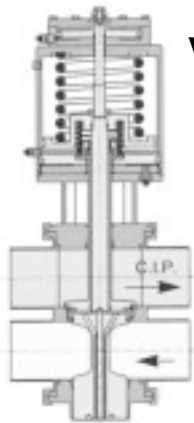

Valve closed

The upper and lower lines are isolated by a releasing chamber allowing the protection of both lines, and the visualization of a possible leak.

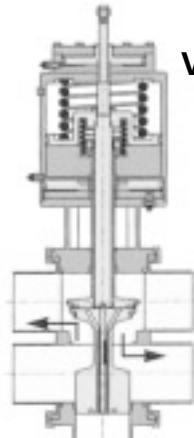

Valve open

Both plugs closed against each other, preventing leakage.

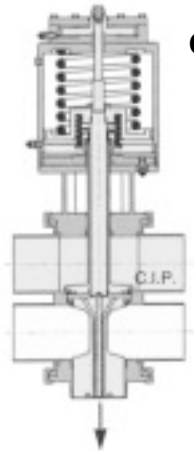

CIP upper line

During the cleaning of the upper line, the stroke of the upper plug allows the cleaning of the upper seal, the bearing face of the seal and the leakage chamber.

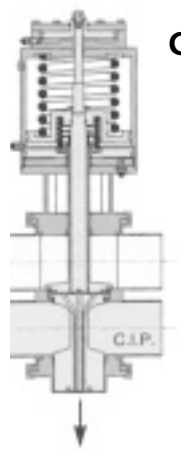

CIP lower line

During the cleaning of the lower line, the stroke of the lower plug allows the cleaning of the lower seal, the bearing face of the seal and the leakage chamber.

Remarks:

Depending on the process, it is sometimes possible to use the stroke of one plug only to clean the valve completely. When the valve doesn't need particular cleaning, it can also be used without break away actuator. It is possible to clean the leakage chamber, when the valve is closed, by inserting a special fitting into the tapped center hole at the bottom of the counterbalance piston, and forcing CIP solution up through the center hole and out through the leakage chamber.

Using of the break away actuators for mix proof valves

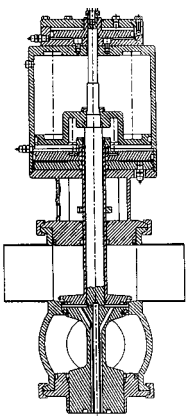

VDCI with 2 break away actuators

The releasing chamber and the bearing faces of the seals can be cleaned with the CIP of one line (valve closed).

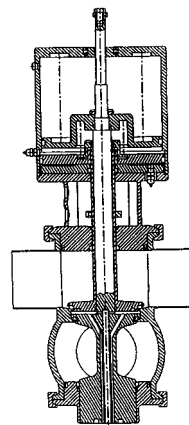

VDCI with 1 break away actuator

The releasing chamber and the bearing faces of the seals can be cleaned during the CIP (valve open and closed).

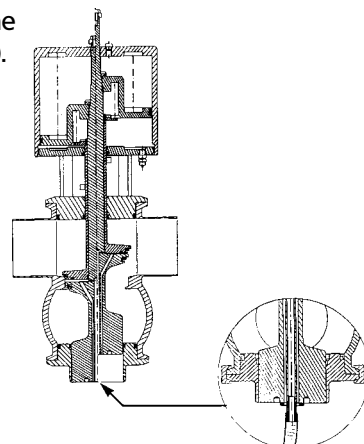

VDCI without break away actuator

The bearing faces of the seals can be cleaned, valve open. The connection to the leakage chamber through a hose allows the cleaning of the releasing chamber, independently of the cleaning of the valve.

Detailed Drawing of VDCI mix proof valve

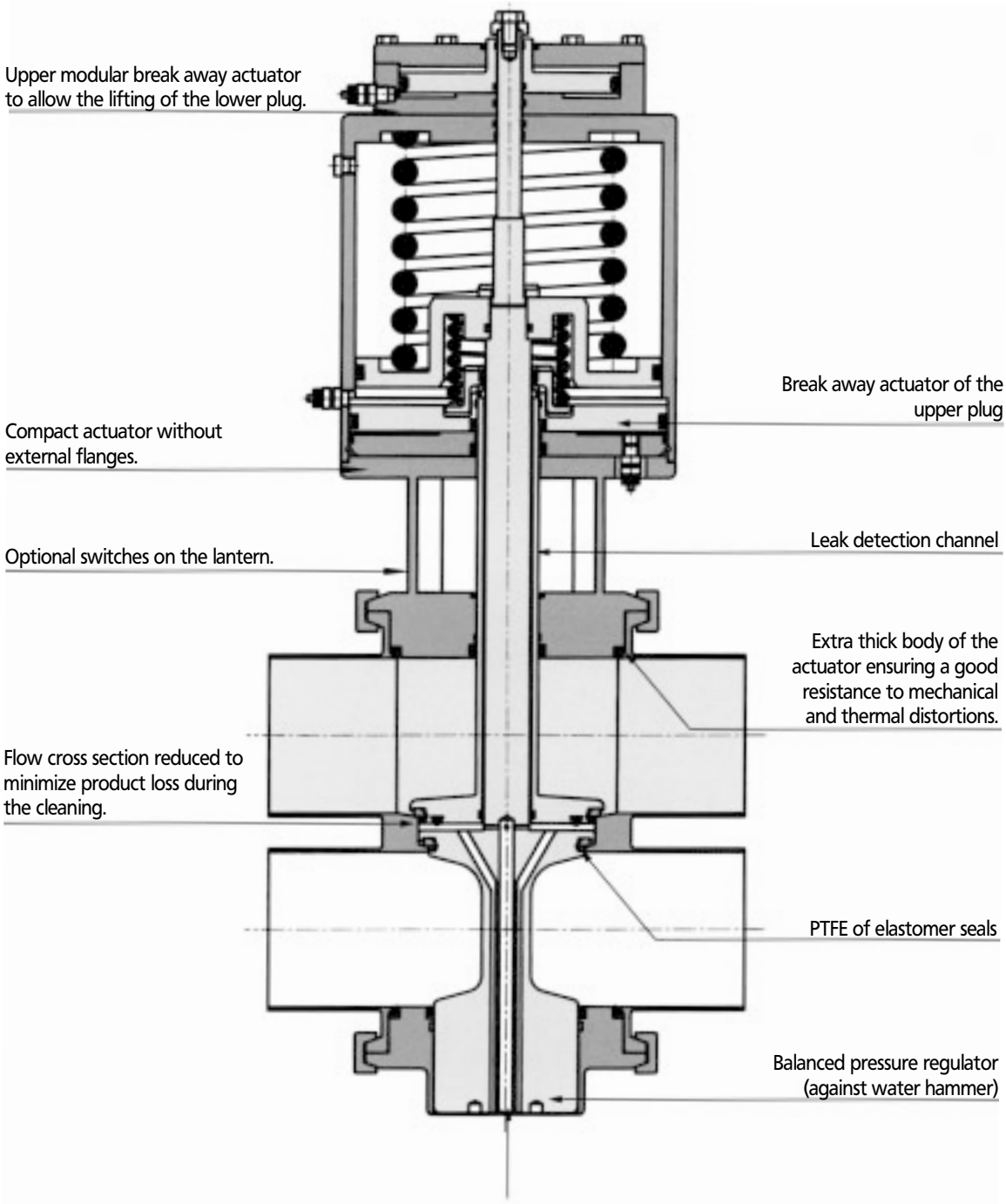

Possibility to actuate the two plugs independently and (or) to clean the chamber area, plugs closed, thanks to a double wall leak detection channel.

VDCI-PMO Mixproof Valve

In order to meet the standards administered by the Pasturized Milk Ordinance, the VDCI-PMO Mixproof valve was developed. This valve incorporates an enlarged leak path that is equal in ID dimension to the valve port size. The VDCI-PMO Mixproof valve is manufactured with the same characteristics and options as the standard VDCI Mixproof valve.

Note: The standard position feedback equipment can be complimented with proximity switches to detect the valve plugs are raised during air space and leak path CIP operations.

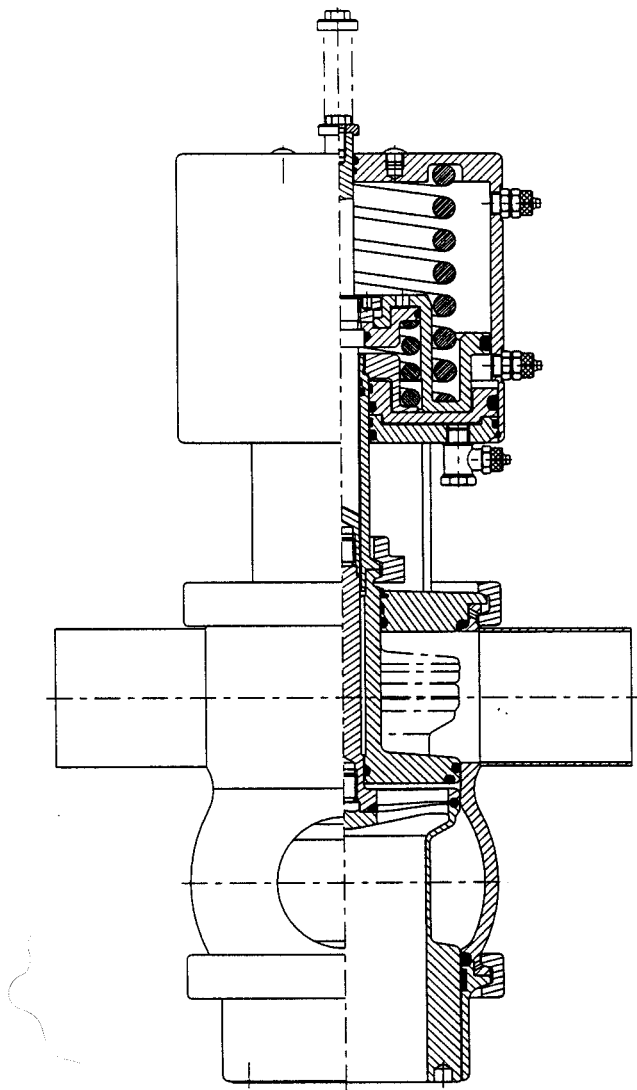

Tank bottom VDCI mix proof valves

General Characteristics

- This valve completes the range of standard mix proof valves.
- Integral flange for welding to tank bottom.
- Eliminates product retention area on tank bottom.
- Central leakage detection.

Dimensions

2" - 2-1/2" - 3" - 4"

Material

- Body and plug: 316L stainless steel
- Plug seal: PFA
- Body seal: viton or EPDM
- Actuator: 304 stainless steel

Valve ends

- On tank: welded integral flange
- On tube: according to the norm, available with many different industry standards (SMS - DIN - CLAMP - tube - etc.)

Options

- Control box on the top of the actuator.

Surface Finish

- External = 47 RA max (150 grit)
- Internal = 32 RA max (180 grit)

Tank bottom VDCI performance curve

Working conditions

Single acting compulsory for double sealing.

SIZE	2" to 2-1/2"	3"	4"
Effective pressure in psi	44	44	44

Pressure drop

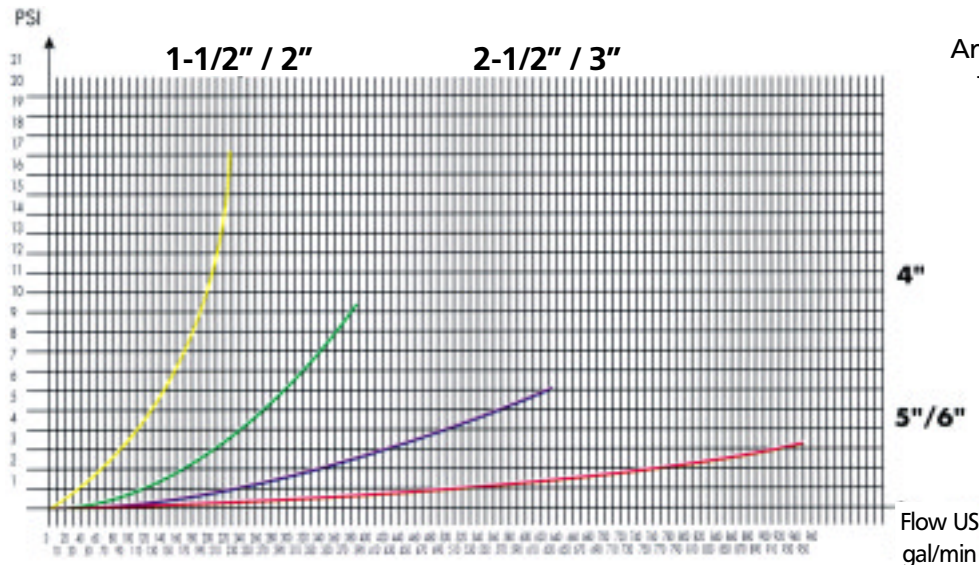

Arrival under the plug

Air supply of the actuator

Filtered dry air from 75 psi min. to 120 psi max. through Rilsan hose. DN 1/4" OD x 1/8" ID (5/16" OD x 3/16" ID)

Permissible maximum temperature

285°F (difference of temperature between the upper and the lower line: max. 195°F)

Vacuum resistance (absolute pressure)

5.8 psi or 12 inches of Hg

Test

Valves meet the requirements of the ISO 5208 norm.

Tank bottom VDCI dimensions

Lowering plug type - Double sealing

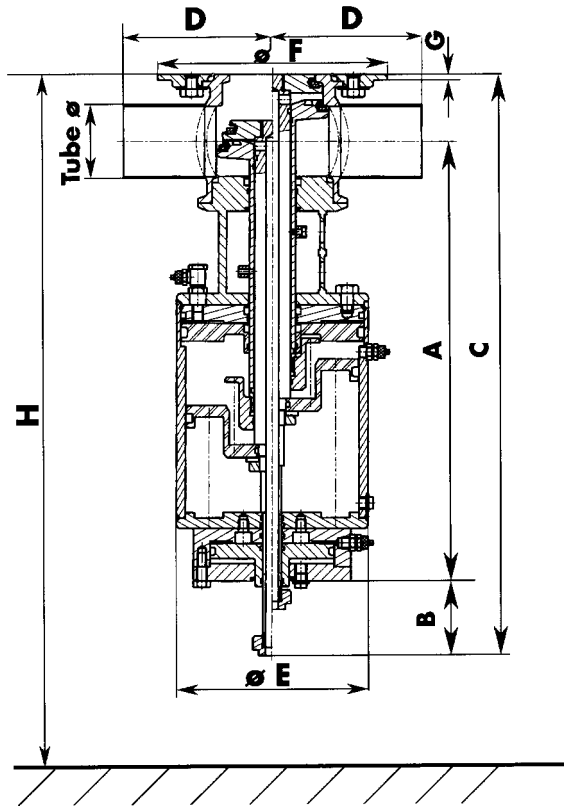

Standard tank bottom - VDCI

SIZE	A	B	C	D	E	F	G
2"	13-3/8"	2-5/16"	17-9/16"	4-1/8"	5-1/16"	7"	3/16"
2-1/2"	14-15/16"	2-9/16"	19-13/16"	5-1/8"	6-5/8"	7-13/16"	3/16"
3"	15-3/16"	2-9/16"	20-1/4"	5-1/8"	6-5/8"	7-13/16"	3/16"
4"	17-1/2"	2-15/16"	23-5/8"	6-1/8"	8-5/8"	10-9/16"	5/16"

Aseptic tank bottom - VDCI

SIZE	A	B	C	D	E	F	G
2"	14"	2-5/16"	18-3/16"	4-1/8"	5-1/16"	7"	3/16"
2-1/2"	16-5/16"	2-9/16"	21-1/8"	5-1/8"	6-5/8"	7-13/16"	3/16"
3"	16-9/16"	2-9/16"	21-5/8"	5-1/8"	6-5/8"	7-13/16"	3/16"
4"	18-15/16"	2-15/16"	25-1/16"	6-1/8"	8-5/8"	10-9/16"	5/16"

Position Feed Back and Control Equipment

Equipment Selection Matrix

DCX3 - DCX4 Standard and Compact Shut Off and Divert Valves, Sizes 1/2" - 6" - Standard Switch Packs

VALVE TYPE	OPTIONAL EQUIPMENT					
	24 VDC SOLENOID VALVE	110 VAC SOLENOID VALVE	1 PC MECHANICAL SPDT SWITCH	2 PCS MECHANICAL SPDT SWITCHES	1 PC PROXIMITY SWITCH	2 PCS PROXIMITY SWITCHES
DCX? 1/2" - 6"	X					
DCX? 1/2" - 6"	X		X			
DCX? 1/2" - 6"	X			X		
DCX? 1/2" - 6"	X				X	
DCX? 1/2" - 6"	X					X
DCX? 1/2" - 6"		X				
DCX? 1/2" - 6"		X	X			
DCX? 1/2" - 6"		X		X		
DCX? 1/2" - 6"		X			X	
DCX? 1/2" - 6"		X				X
DCX? 1/2" - 6"			X			
DCX? 1/2" - 6"				X		
DCX? 1/2" - 6"					X	
DCX? 1/2" - 6"						X

DCX3 - DCX4 Standard and Compact Shut Off and Divert Valves, Sizes 1/2" - 6" - AS-i

VALVE TYPE	OPTIONAL EQUIPMENT			
	ASI-CONTROL			
	24 VDC SOLENOID VALVE	110 VAC SOLENOID VALVE	1 PC PRISMATIC SWITCH	2 PCS PRISMATIC SWITCHES
DCX? 1/2" - 6"	1 PC PILOT & INTERFACE		X	
DCX? 1/2" - 6"	1 PC PILOT & INTERFACE			X

VDCI - Mix Proof Valves, Sizes 1-1/2" - 6" - Standard Switch Packs

VALVE TYPE	OPTIONAL EQUIPMENT							
	1 PC 24 VDC SOLENOID VALVE	2 PCS 24 VDC SOLENOID VALVES	3 PCS 24 VDC SOLENOID VALVES	1 PC 110 VAC SOLENOID VALVE	2 PCS 110 VAC SOLENOID VALVES	3 PCS 110 VAC SOLENOID VALVES	1 PC PROXIMITY SWITCH	2 PCS PROXIMITY SWITCHES
VDCI 1-1/2" - 6"	X						X	
VDCI 1-1/2" - 6"	X							X
VDCI 1-1/2" - 6"		X					X	
VDCI 1-1/2" - 6"		X						X
VDCI 1-1/2" - 6"			X				X	
VDCI 1-1/2" - 6"			X					X
VDCI 1-1/2" - 6"				X			X	
VDCI 1-1/2" - 6"				X				X
VDCI 1-1/2" - 6"					X		X	
VDCI 1-1/2" - 6"					X			X
VDCI 1-1/2" - 6"						X	X	
VDCI 1-1/2" - 6"						X		X

VDCI - Mix Proof Valves, Sizes 1-1/2" - 6" - AS-i

VALVE TYPE	OPTIONAL EQUIPMENT							AS-I CONTROL	
	1 PC 24 VDC SOLENOID VALVE	2 PCS 24 VDC SOLENOID VALVES	3 PCS 24 VDC SOLENOID VALVES	1 PC 110 VAC SOLENOID VALVE	2 PCS 110 VAC SOLENOID VALVES	3 PCS 110 VAC SOLENOID VALVES	1 PC PRISMATIC SWITCH	2 PCS PRISMATIC SWITCHES	
VDCI 1-1/2" - 6"	1 PC PILOT & INTERFACE						X		
VDCI 1-1/2" - 6"	1 PC PILOT & INTERFACE							X	
VDCI 1-1/2" - 6"	N/A	X					X		
VDCI 1-1/2" - 6"	N/A	X						X	
VDCI 1-1/2" - 6"	N/A		X				X		
VDCI 1-1/2" - 6"	N/A		X					X	



Standard control box with stainless steel cover



Optional control box with plastic or stainless steel cover

WESTLOCK control equipment also available:

17

Standard Switch Packs

- Mechanical
- Proximity
- Explosion Proof

Network Switch Packs

- DeviceNet®
- AS-i® 2.1
- Foundation Fieldbus®
Others on request

Positioners

- ICoT®

Available in valve mounted and remote mount versions



MODBUS



TOP LINE ... *experienced and responsive to your needs*

Top Line has been supplying high quality stainless steel products to the dairy, food, beverage, pharmaceutical and other process industries for over twenty-five years. Our commitment to fine craftsmanship, responsible service and realistic pricing has led to our company's successive years of growth.

Top Line specializes in stainless steel materials – types 304, 316, and “L grades”.

Our modern, well equipped manufacturing facilities are staffed by skilled and dedicated craftsmen. Consistently meeting important tolerances and finish specifications is of primary concern to us. Before any products leave our plant they are subjected to rigid quality assurance checks.

Top Line should always be considered your first choice for both standard and custom fabricated stainless steel products.

LIMITED WARRANTY

Top Line Process Equipment Company products are warranted to be free of defects in material or workmanship for a period of one year from date of shipment. Warranty covers those Top Line products used in an approved installation and maintained in strict accordance with recognized standard industry practice. If, after properly authorized return, Top Line determines that products are defective, Top Line may at its option, repair or replace such defective products.

Top Line shall not be liable for consequential, indirect or incidental damages. The above warranty is in lieu of all other warranties, expressed or implied.

CONTACT YOUR TOP LINE SALES REPRESENTATIVE FOR ASSISTANCE

Office: P.O. Box 264
Bradford, PA 16701

Plant: 21 Valley Hunt Drive
Lewis Run, PA 16738



Phone: 800-458-6095
814-362-4626
FAX: 814-362-4453

E-mail:
topline@toplineonline.com

www.toplineonline.com