



# Gunclean Toftejorg 270FT Mark I

## Tank and hold cleaning machine

The Gunclean Toftejorg 270FT Mark I is a fully programmable turbine driven single nozzle tank cleaning machine. Of all brands and makers the 270FT is the most sold single nozzle tank cleaning machine for crude oil tankers and bulk carriers.

### Application

The Gunclean Toftejorg 270FT Mark I is designed for fixed installations onboard crude oil, bulk, product carriers, and FPSO's.

### Operation

The turbine driven Gunclean Toftejorg 270FT Mark I model will immediately be in operation for cleaning by just opening the supply valve. An easy selection between four different cleaning programmes is offered, from quick cleaning to tight pitch cleaning for heavy duty.

All programmes are available by turning the knob on the power unit before or during cleaning. Nozzle position can be adjusted either before or during operation. The rotation speed can be set between 1–2 rpm.

### Cleaning pattern

The nozzle performs a helical cleaning pattern by a slow vertical movement of the nozzle while the cleaner head is rotating in the horizontal plane. The power unit is designed to give a tighter cleaning pattern in the bottom of the tank or hold, where it is generally most needed.

### Options

- Inlet flange according to JIS and ANSI standard.
- Deck flange with customized dimensions.
- Split extension pipe.
- Sensor connection for all cargo control systems.
- Capacity up to 115 m<sup>3</sup>/hour.
- Gasket & Sealings.
- Strainer in flange.
- Nozzle turning angle 170°.

### Regulations

The equipment fully complies with IMO regulations and the requirements of the classification societies.



Gunclean Toftejorg 270FT Mark I.

### Specifications

Materials, main parts (standard version)	
Inlet housing	Ductile cast iron, hot galvanized
Extension pipe	Steel, hot galvanized
Lower assembly	Bronze
Cover	Stainless steel & coated
Sealings	Viton/Nitril
Weight	
Machine with 1.0 m length of main pipe	95 kg
Per additional metre of main pipe	20 kg
(Standard version up to 4 metres ext. pipe)	
Lubricant	Oil or grease
Working pressure	7–12 bar (105–195 psi)
Capacity	30–120 m <sup>3</sup> /hour
Max. working temperature	85°C (185°F)
Programmable pitch	4 different settings from 1°–8.5°
Sealings	
Gas	0–0.5 bar (0–7.5 psi)
Water/oil	0–13 bar (0–195 psi)
Installation	Fixed

**Performance data:**  
Flow rate, nozzles Ø18–25

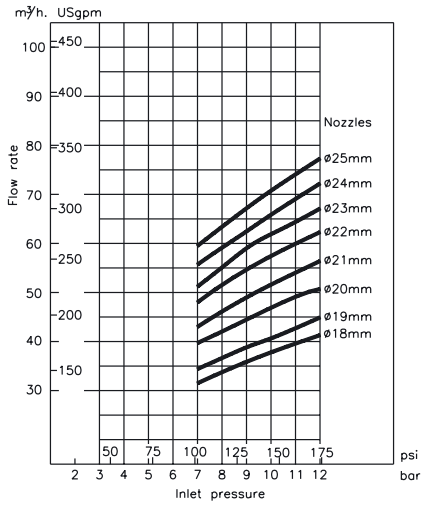

**Performance data:**  
Flow rate, nozzles Ø26–32

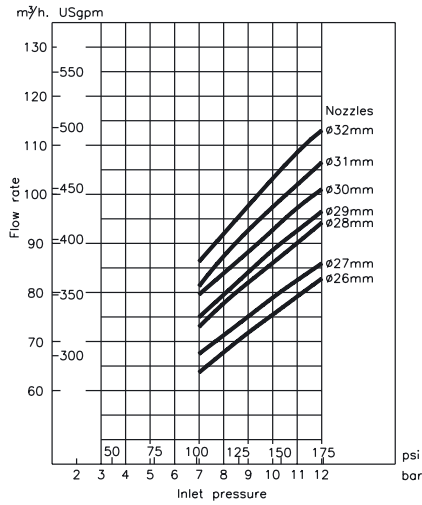

**Recommended design throw length at static condition**

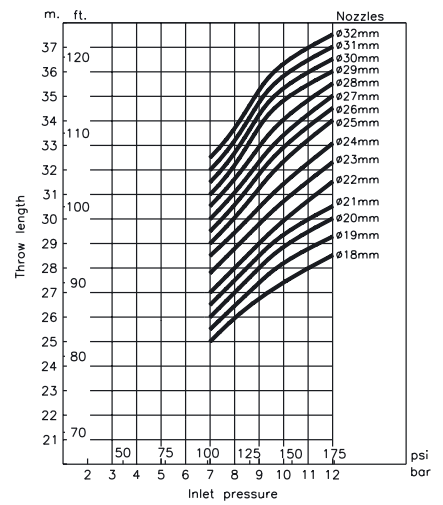

**Cleaning pattern**

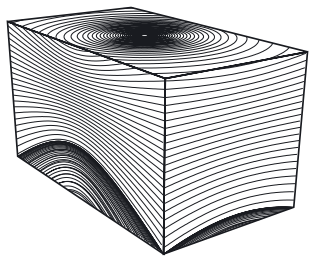

Dense pattern

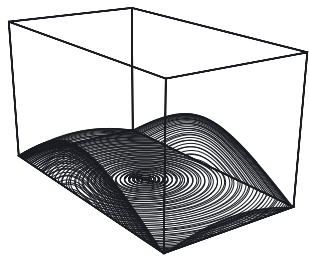

Bottom pattern

**Dimensions (mm)**

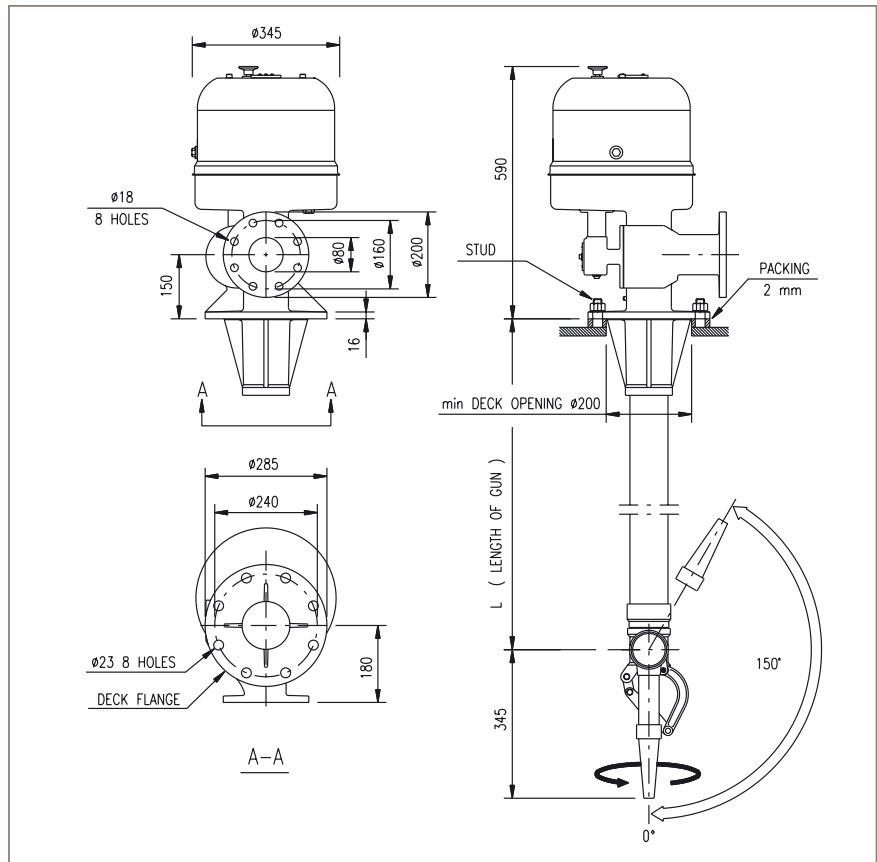

EMD00020EN 0511

Alfa Laval reserves the right to change specifications without prior notification.

**How to contact Alfa Laval**  
Up-to-date Alfa Laval contact details for all countries are always available on our website at [www.alfalaval.com](http://www.alfalaval.com)