



## Centrifugal Pump Model TF-C Series



Stainless Steel Flow Control Equipment for the  
Food, Beverage, Dairy, Cosmetics, Biotechnology,  
Pharmaceutical and Electronics Processing Industries

# TOP-FLO®

The centrifugal pump for the process industry.

## Contents

Introduction .....	IFC
Ordering Information .....	1
C-Series Specification .....	2-3
Pump Sizing Guide .....	4
Head Capacity Curve Charts.....	5-22
Viscosity and Specific Gravity Table .....	23
Friction Loss Table .....	24
Pump Dimensions .....	25
Ordering Sheet .....	IBC

## Introduction

The TOP-FLO® name represents the finest in sanitary process equipment. TOP-FLO® pumps have been designed to offer efficient transfer of product over a wide range of head and viscosity conditions. TOP-FLO® pumps are easy to install, clean, and operate.

This catalog will answer many of the questions you may have regarding TOP-FLO® pumps. If you require additional information, a representative will be happy to assist you. A representative can be reached at 1-800-458-6095.

TOP-FLO® pumps are suitable for use in CIP (clean in place) installations. This feature enables easy self-cleaning with no dismantling or take-down. Sanitizing of all product contact areas is automatic.

All TOP-FLO® pumps are available in standard inlet sizes and outlet sizes. In addition, enlarged inlet sizes are available for special applications.

# Pump Ordering Information

Determining the model number of your pump is easy as 1-2-3-4.



① **PUMP SERIES**  
TF-C Close Coupled

② **CASING SIZE**

②	⑫	⑧
Inlet Size 2"	Outlet Size 1/2"	Maximum Impeller Dia. 8"

Note:

- TF-C Series furnished complete with legs unless otherwise specified on order.
- Casing Gaskets: BUNA - is standard. If other type is required, specify on order.
- Enlarged inlet: When ordering pump with enlarged inlet state inlet size, i.e., TF-C218MD with 3" inlet.

③ **PORT CONNECTIONS**

M - Clamp  
T - Acme Bevel Seat Thread  
S - NPT Female Thread  
F - Flanged  
W - Weld

**TYPE OF SEAL/STANDARD MATE-**

④ D - External balanced sanitary seal  
DG - External balanced sanitary seal w/clamped insert  
E - Water cooled balanced double seal  
F - External balanced seal w/cascading water

**Motor Data** is not included as part of 4-step ordering number.

Provide the following information:

- Horsepower and RPM
- Electrical phase and voltage
- (Leeson washdown is standard)

If motor is furnished from another source, supply the following:

- Horsepower
- RPM
- NEMA frame size

Remember to order needed accessories:

- Check Valve
- Seal Kits and Parts
- Gaskets
- Clamps
- Hangers
- Butterfly Valves
- Ball Valves



Model No.	TF-C114	TF-C216	TF-C218	TF-C328
Inlet	1-1/2" or 2"	2" or 2-1/2"	2" or 3"	3" or 4"
Outlet	1-1/2"	1-1/2"	1-1/2"	2"
Max. Imp.	4"	6"	8"	8"

## PUMP SPECIFICATIONS

### Pump Casings:

- Volute type - Standard.
- Inlet-oversizing as noted in chart above.

### Pump Connections:

- |                     |                    |
|---------------------|--------------------|
| <b>SANITARY:</b>    | <b>INDUSTRIAL:</b> |
| • Clamp             | • Threaded         |
| • Bevel Seat (ACME) | • Flanged          |

### Pump Construction Materials:

- All wetted parts - 316 SS.
- Seals - Carbon (other seals available)
- Casing Gasket - BUNA-N (Standard)
- Viton & Teflon are available.

### Pump Finishes:

- Polished or Electropolished

### Pump Seals:

- Available in D, E, and F styles

### Motor, Electrical:

- 3 Phase - 230/460 volts - 1750 & 3500 rpm.
- Single Phase - 115/230 volts - 1750 & 3500 rpm.

### Motor Housings:

- TEFC (Totally Enclosed Fan Cooled)
- Easy Clean
- Other styles available on request

**For light duty transfer requirements, see Top Line brochure on the TF-C100.**

## SEAL SPECIFICATIONS

### **TYPE D External Balanced Seal (Sanitary)**

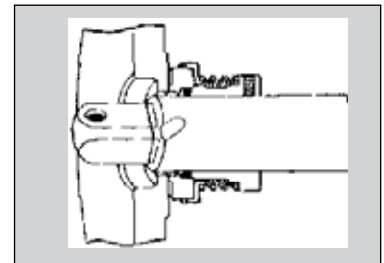

This versatile seal has numerous applications but yet is extremely durable. Dairy products, soft vegetables, beverages and even acid cleaning solutions and detergents are among the recommended uses.

### **TYPE E Water Cooled Balanced Double Seal (Sanitary)**

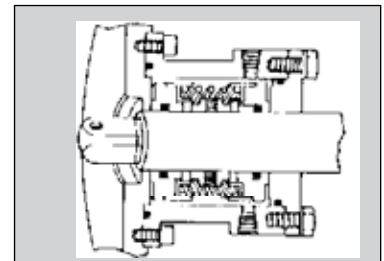

Type E is designed to withstand heavy duty vacuum applications (to 28" Hg), tacky products, slurries, or pumped products which may exceed 212°F. The seal chamber can be pressurized to permit use of drain piping for coolants and sealants.

### **TYPE F - (Sanitary)**

Seal same as Type D seal except includes a water cascade (not shown).

All sanitary seals meet 3A accepted practices.

# TOP-FLO® pumps are top performers using numerous features

**Type F seal:** Water cascade attachment is recommended for pumping tacky or hot products up to 212° F, and for vacuum applications to 14" Hg.

**Superior seal:** Provides a longer life and less downtime. High grade finish reduces pressure at sealing surface results in less wear and greater efficiency.

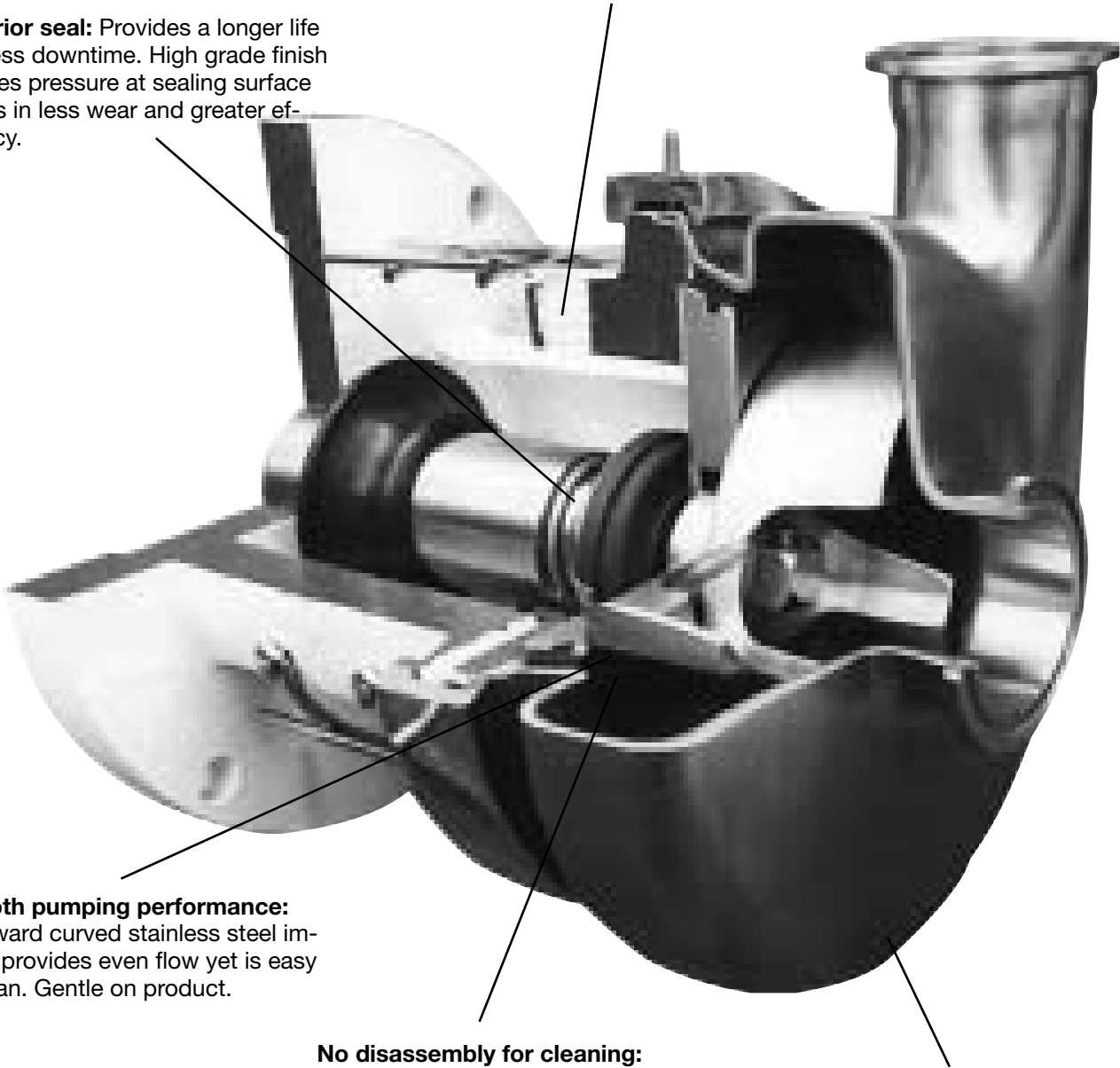

**Smooth pumping performance:** Backward curved stainless steel impeller provides even flow yet is easy to clean. Gentle on product.

**No disassembly for cleaning:** Unique groove-in-shaft design directs sanitizer to all critical areas. A must for clean-in-place applications.

**Casing:** Finely polished casing suitable to meet numerous requirements. Casing available in a wide selection of port connections to meet a variety of piping systems.

# TOP-FLO® Pump Sizing Application Data

## Use of a Pump Curve Chart

The curve chart is the best resource to use when selecting the proper impeller and motor for applications in the Food, Dairy, Beverage, Pharmaceutical and Cosmetic industries. The curve chart enables the user to determine how a pump will perform at different impeller sizes and motor speeds.

Operating at 1750 RPM and 3500 RPM, curves have been listed for the TOP-FLO® TF-C114, TF-C216, TF-C218 and TF-C328 centrifugal pumps on the following pages. An instructional chart is listed below.

**Note:** Column #1 on the left shows Head in Feet.  
 Column #2 at the bottom shows Gallons Per Minute.  
 Impeller sizes are listed on curve line  
 Motor horsepower listed on diagonal serrated lines.  
 NPSH required is #3 and listed at the bottom of chart

**Example:** On the curve listed below, find the impeller size and horsepower of motor for 75 GPM against total head pressure of 40 feet.

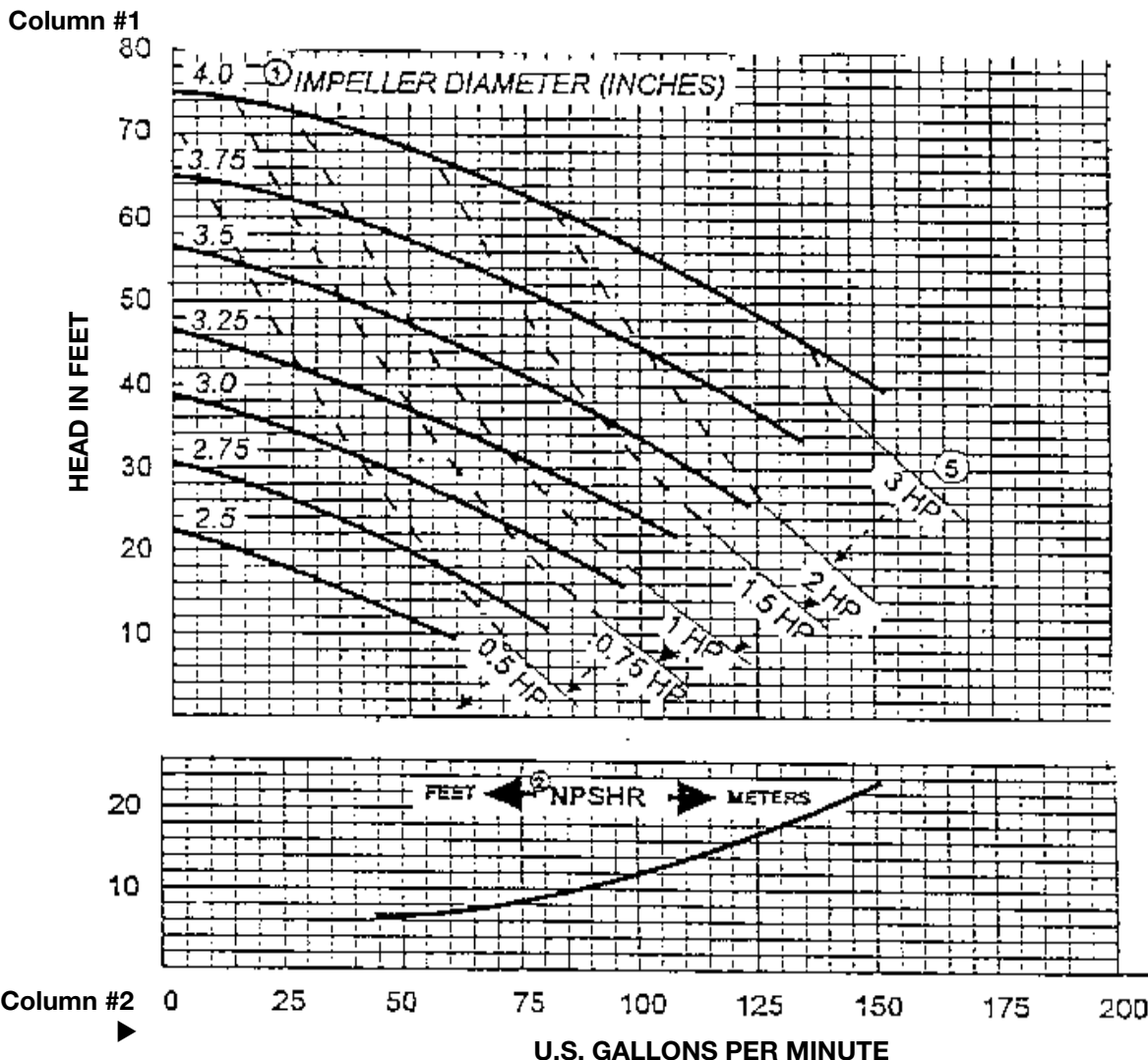

**Answer to example:**

- To determine duty point: Find first the 35 feet of head in column #1. Second, find the 75 gallon per minute in column #2. Then, trace the 35 feet of head mark to the right until it intersects the 75 GPM line.
- To determine impeller diameter. The duty point falls between the 3.25 and 3.5 impeller curve lines. Always choose the curve line above the duty point. In this case it would be 3.5 inches.
- To determine NPSHR (Net Positive Suction Head Required): Use the NPSHR graph and plot the intersection point of 75 GPM. Follow horizontally to the left. It reads 9 feet. (This will be Net Positive Suction Head Required.)
- You will see at this point a 3.25 impeller and a 1-1/2 horsepower motor is required.

Note: NPSHA (Net Positive Suction Available) must be  $\geq$  NPSHR (Net Positive Suction Head Required).

# TOP-FLO® TF-C Series Centrifugal

## Capacity Curves

Based on water at 70°F (22°C)

**Model: C100**  
**60 Hz                      1750 RPM**  
**Size: 1-1/2 x 1 x 3-11/16**

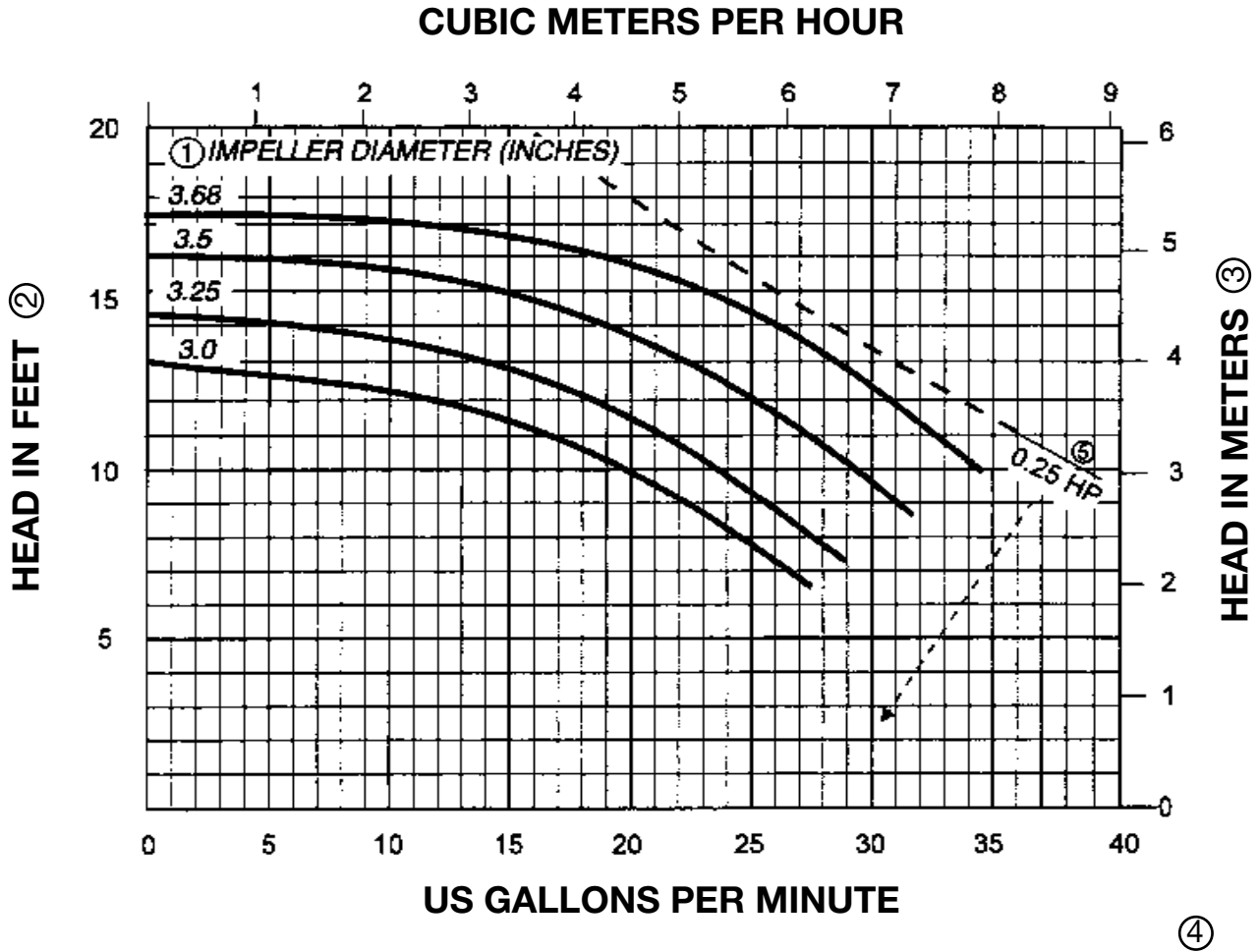

**NOTES:**

- ① Impeller diameters available in 1/16-inch increments
- ②  $PSI = \frac{\text{Head in Feet} \times \text{Specific Gravity}}{2.3}$
- ③  $Kg/cm^2 = \frac{\text{Head in Meters} \times \text{Specific Gravity}}{10}$
- ④  $HP \times 0.746 = Kw$

Office: P.O. Box 264 • Bradford, PA 16701  
 Plant: 21 Valley Hunt Drive • Lewis Run, PA 16738  
 Phone: 800-458-6095 • 814-362-4626 • FAX 814-362-4453



# TOP-FLO® TF-C Series Centrifugal

## Capacity Curves

Based on water at 70°F (22°C)

Model: C114

60 Hz

1750 RPM

Size: 1-1/2 x 1-1/2 x 4

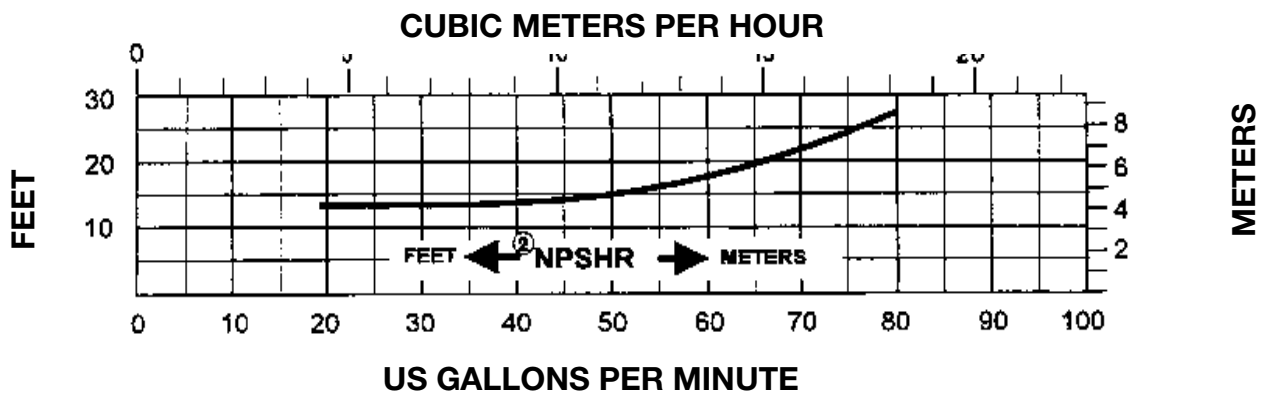
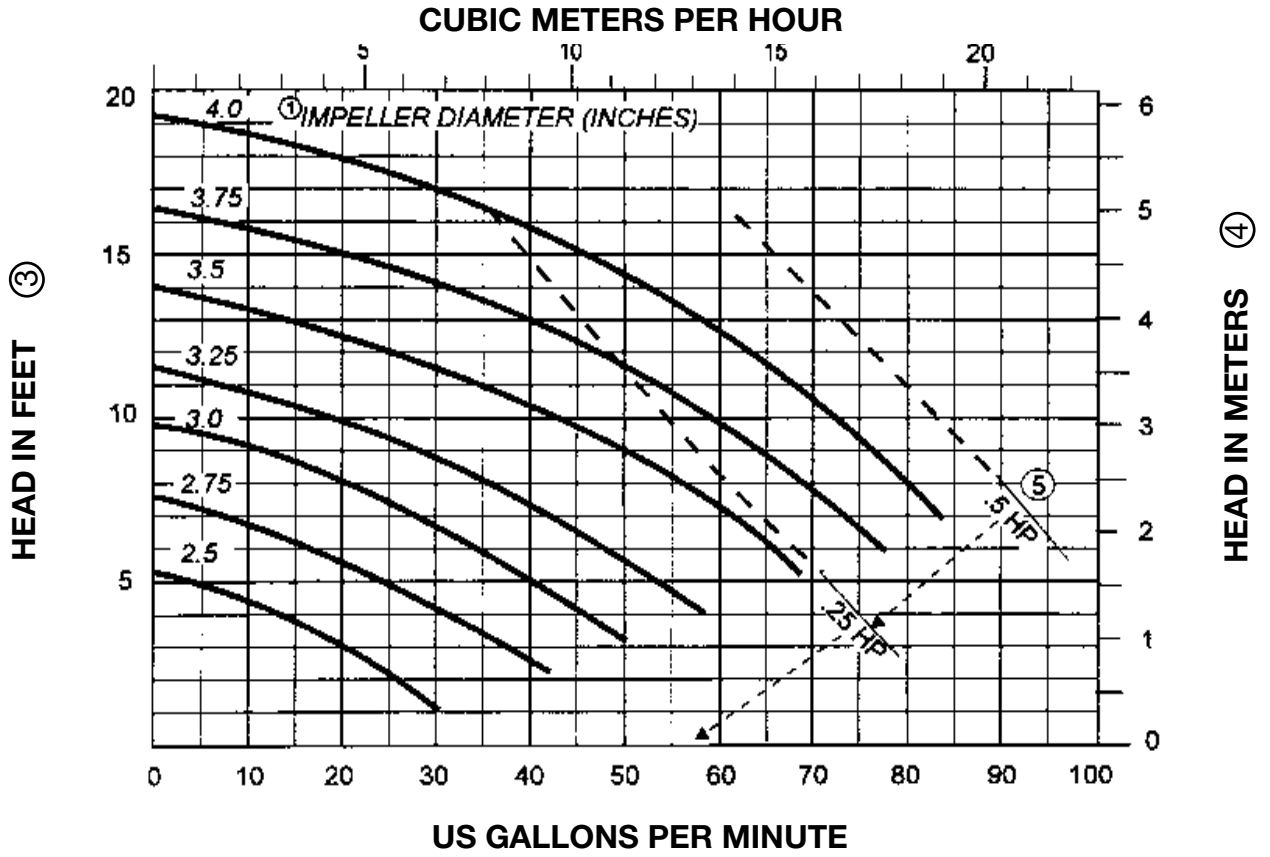

**NOTES:**

- ① Impeller diameters available in 1/4-inch increments
- ② NPSHR is shown for maximum impeller diameter
- ③  $PSI = \frac{\text{Head in Feet} \times \text{Specific Gravity}}{2.3}$
- ④  $Kg/cm^2 = \frac{\text{Head in Meters} \times \text{Specific Gravity}}{10}$
- ⑤  $HP \times 0.746 = Kw$

Office: P.O. Box 264 • Bradford, PA 16701  
 Plant: 21 Valley Hunt Drive • Lewis Run, PA 16738  
 Phone: 800-458-6095 • 814-362-4626 • FAX 814-362-4453



# TOP-FLO® TF-C Series Centrifugal

## Capacity Curves

Based on water at 70°F (22°C)

Model: C114

60 Hz

1750 RPM

Size: 2 x 1-1/2 x 4

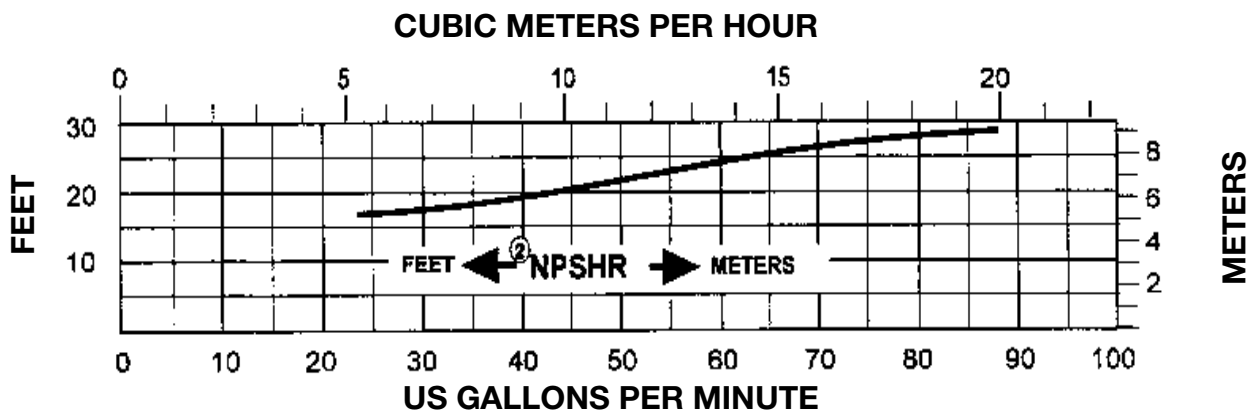
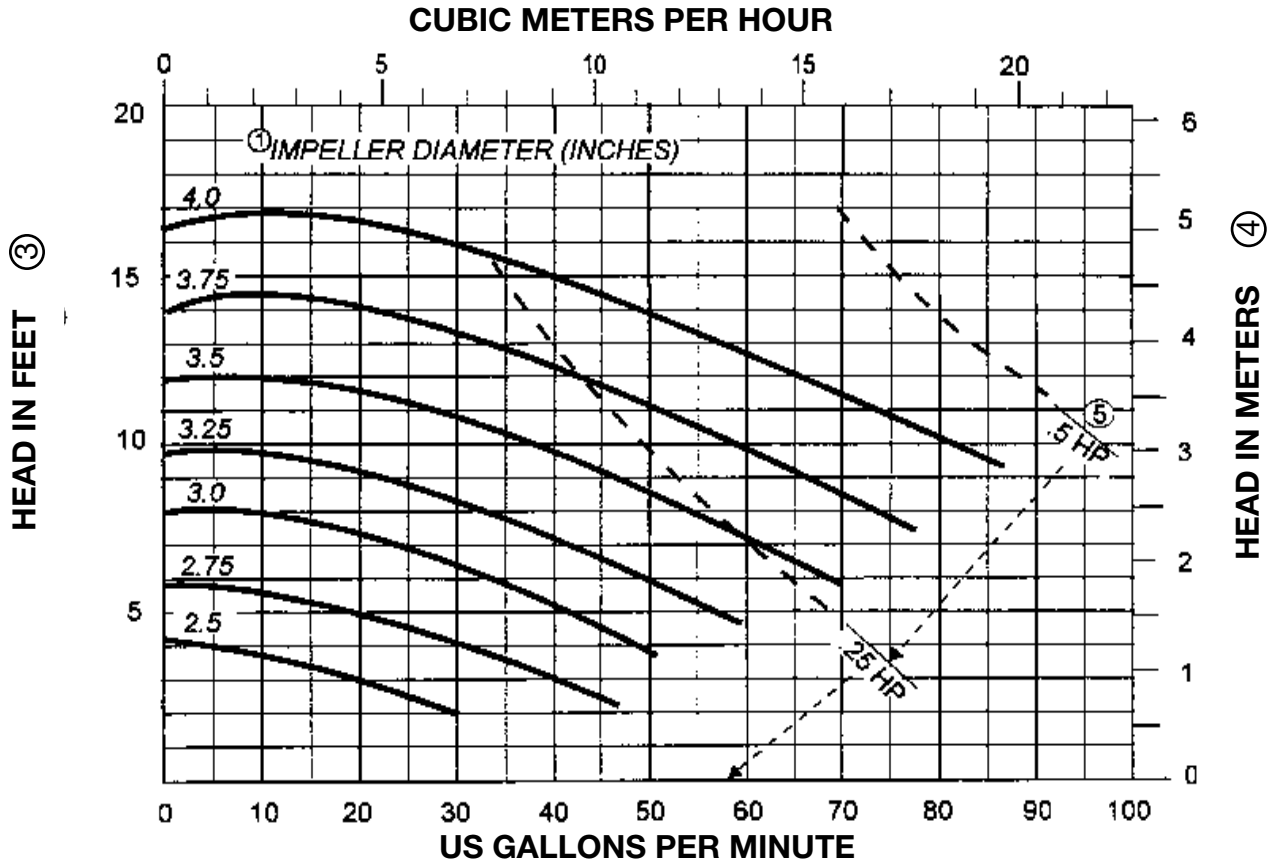

**NOTES:**

① Impeller diameters available in 1/16-inch increments

② NPSHR is shown for maximum impeller diameter

③ PSI =  $\frac{\text{Head in Feet} \times \text{Specific Gravity}}{2.3}$

④  $\text{Kg/cm}^2 = \frac{\text{Head in Meters} \times \text{Specific Gravity}}{10}$

⑤  $\text{HP} \times 0.746 = \text{Kw}$

Office: P.O. Box 264 • Bradford, PA 16701  
 Plant: 21 Valley Hunt Drive • Lewis Run, PA 16738  
 Phone: 800-458-6095 • 814-362-4626 • FAX 814-362-4453



# TOP-FLO® TF-C Series Centrifugal

## Capacity Curves

Based on water at 70°F (22°C)

Model: C216

60 Hz

1750 RPM

Size: 2 x 1-1/2 x 6

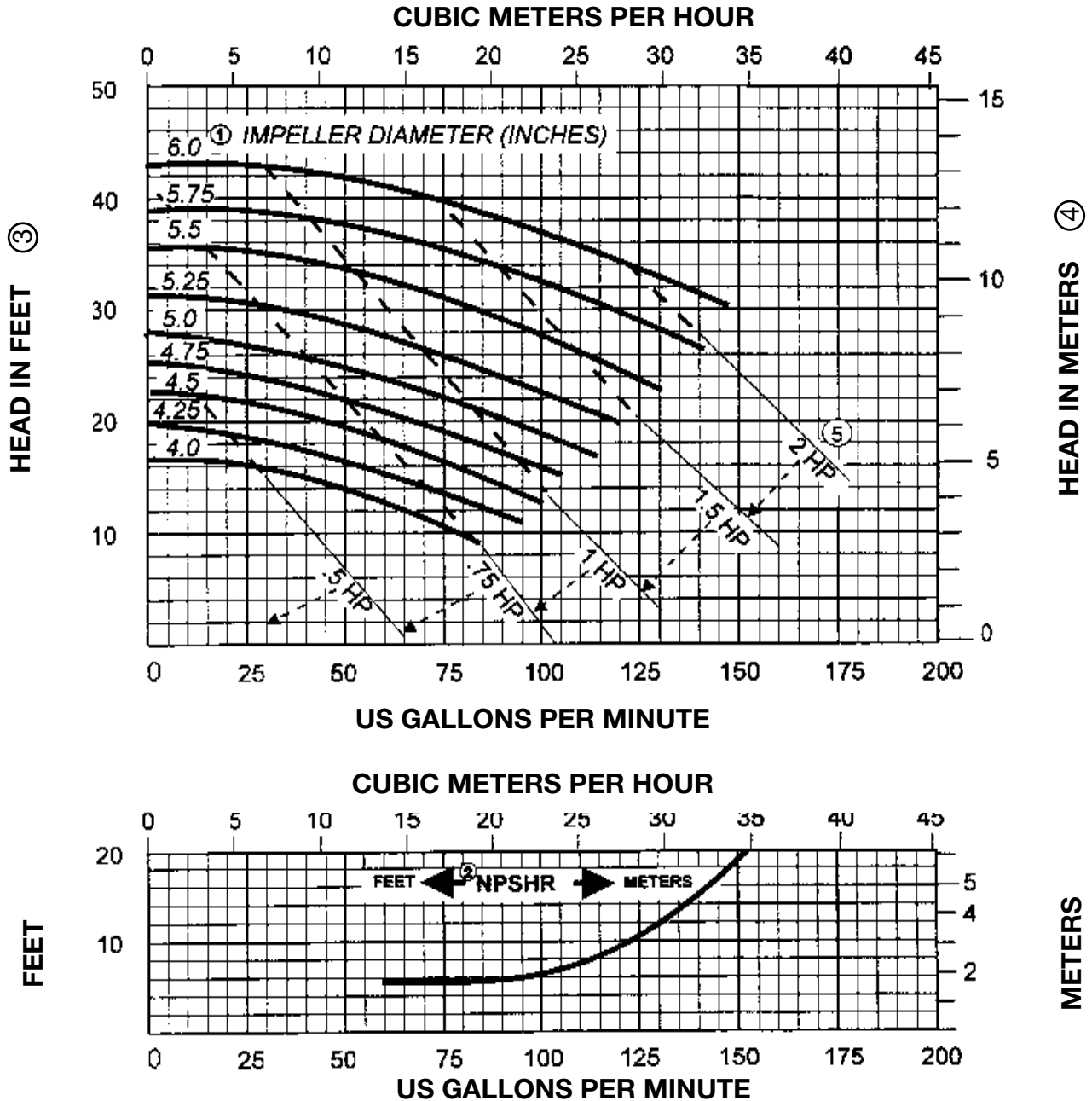

**NOTES:**

① Impeller diameters available in 1/4-inch increments

② NPSHR is shown for maximum impeller diameter

③  $PSI = \frac{\text{Head in Feet} \times \text{Specific Gravity}}{2.3}$

④  $Kg/cm^2 = \frac{\text{Head in Meters} \times \text{Specific Gravity}}{10}$

⑤  $HP \times 0.746 = Kw$

Office: P.O. Box 264 • Bradford, PA 16701  
 Plant: 21 Valley Hunt Drive • Lewis Run, PA 16738  
 Phone: 800-458-6095 • 814-362-4626 • FAX 814-362-4453

**TOP LINE**  
 PROCESS EQUIPMENT COMPANY

# TOP-FLO® TF-C Series Centrifugal

## Capacity Curves

Based on water at 70°F (22°C)

Model: C216

60 Hz

1750 RPM

Size: 2-1/2 x 1-1/2 x 6

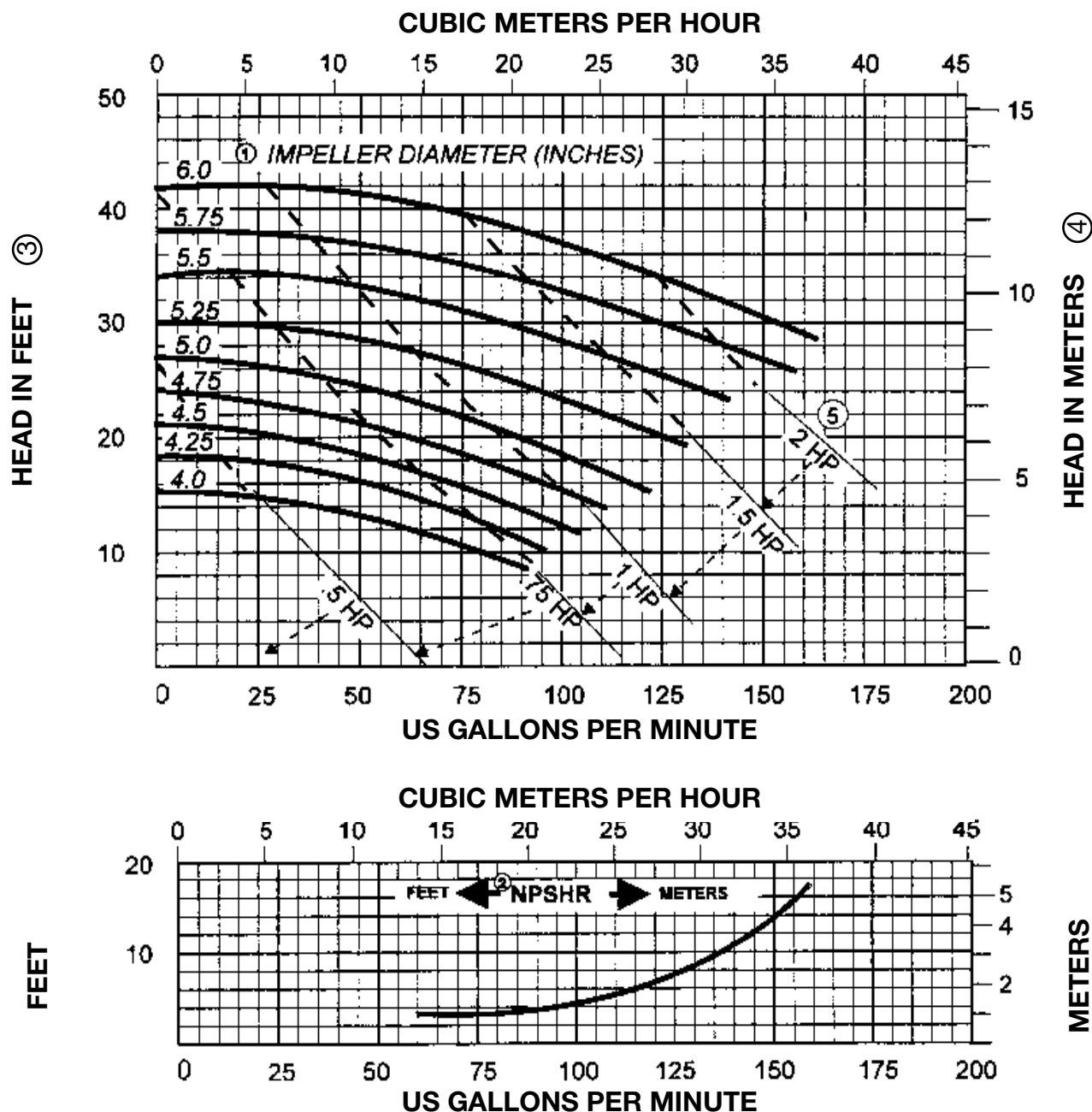

### NOTES:

① Impeller diameters available in 1/4-inch increments

② NPSHR is shown for maximum impeller diameter

③  $PSI = \frac{\text{Head in Feet} \times \text{Specific Gravity}}{2.3}$

④  $Kg/cm^2 = \frac{\text{Head in Meters} \times \text{Specific Gravity}}{10}$

⑤  $HP \times 0.746 = Kw$

Office: P.O. Box 264 • Bradford, PA 16701  
 Plant: 21 Valley Hunt Drive • Lewis Run, PA 16738  
 Phone: 800-458-6095 • 814-362-4626 • FAX 814-362-4453

**TOP LINE**  
 PROCESS EQUIPMENT COMPANY

# TOP-FLO® TF-C Series Centrifugal

## Capacity Curves

Based on water at 70°F (22°C)

Model: C218

60 Hz

1750 RPM

Size: 2 x 1-1/2 x 8

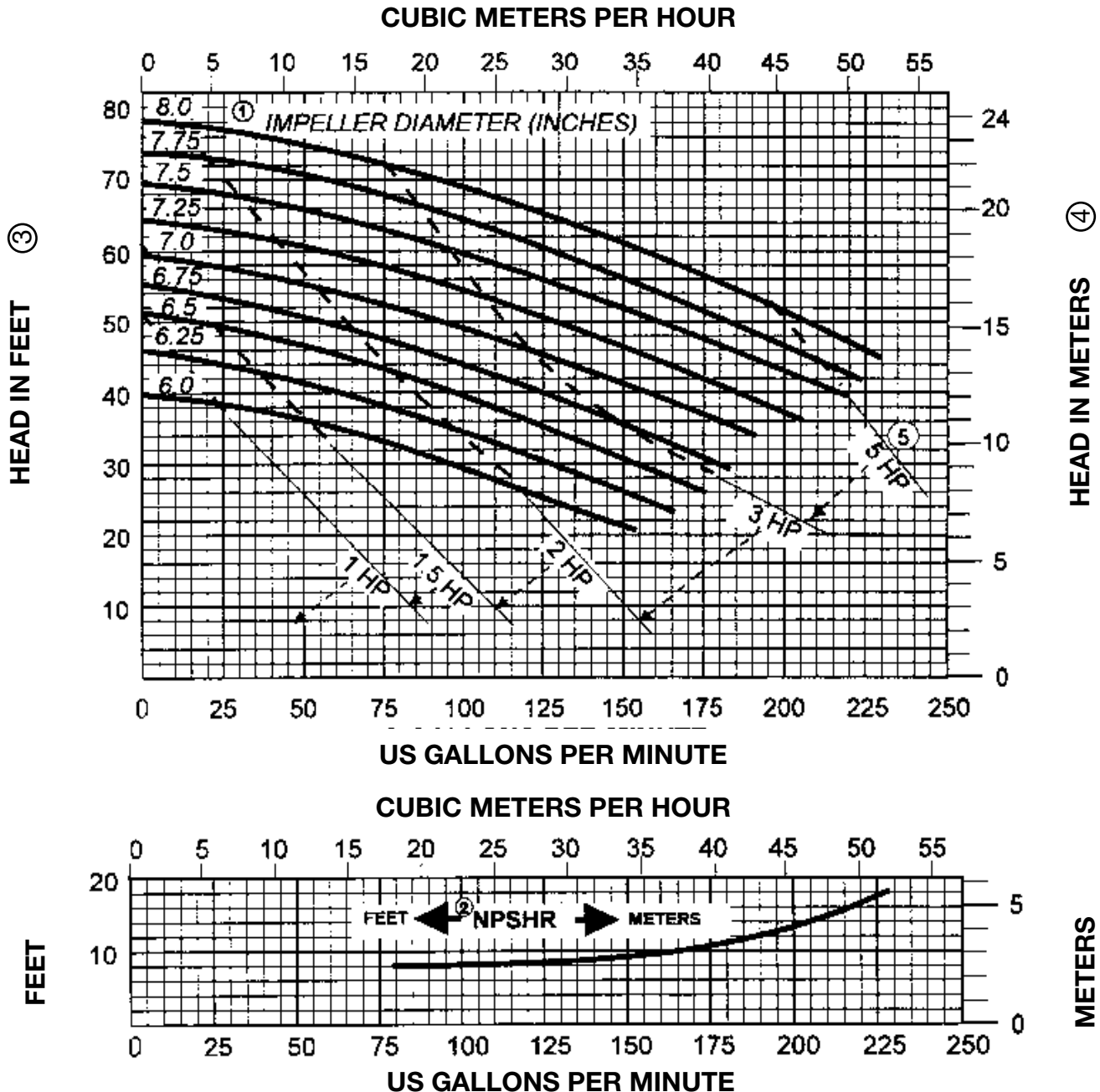

**NOTES:**

- ① Impeller diameters available in 1/4-inch increments
- ② NPSHR is shown for maximum impeller diameter
- ③  $PSI = \frac{\text{Head in Feet} \times \text{Specific Gravity}}{2.3}$
- ④  $Kg/cm^2 = \frac{\text{Head in Meters} \times \text{Specific Gravity}}{10}$
- ⑤  $HP \times 0.746 = Kw$

Office: P.O. Box 264 • Bradford, PA 16701  
 Plant: 21 Valley Hunt Drive • Lewis Run, PA 16738  
 Phone: 800-458-6095 • 814-362-4626 • FAX 814-362-4453



# TOP-FLO® TF-C Series Centrifugal

## Capacity Curves

Based on water at 70°F (22°C)

Model: C218

60 Hz

1750 RPM

Size: 3 x 1-1/2 x 8

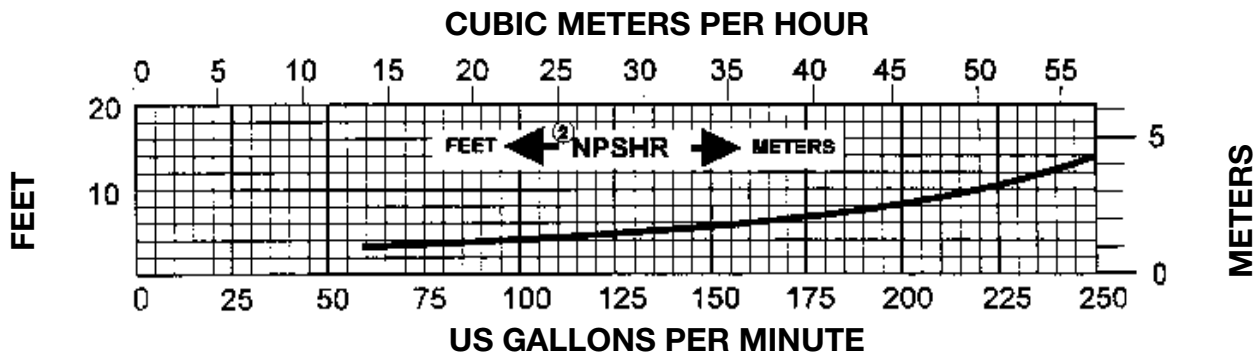
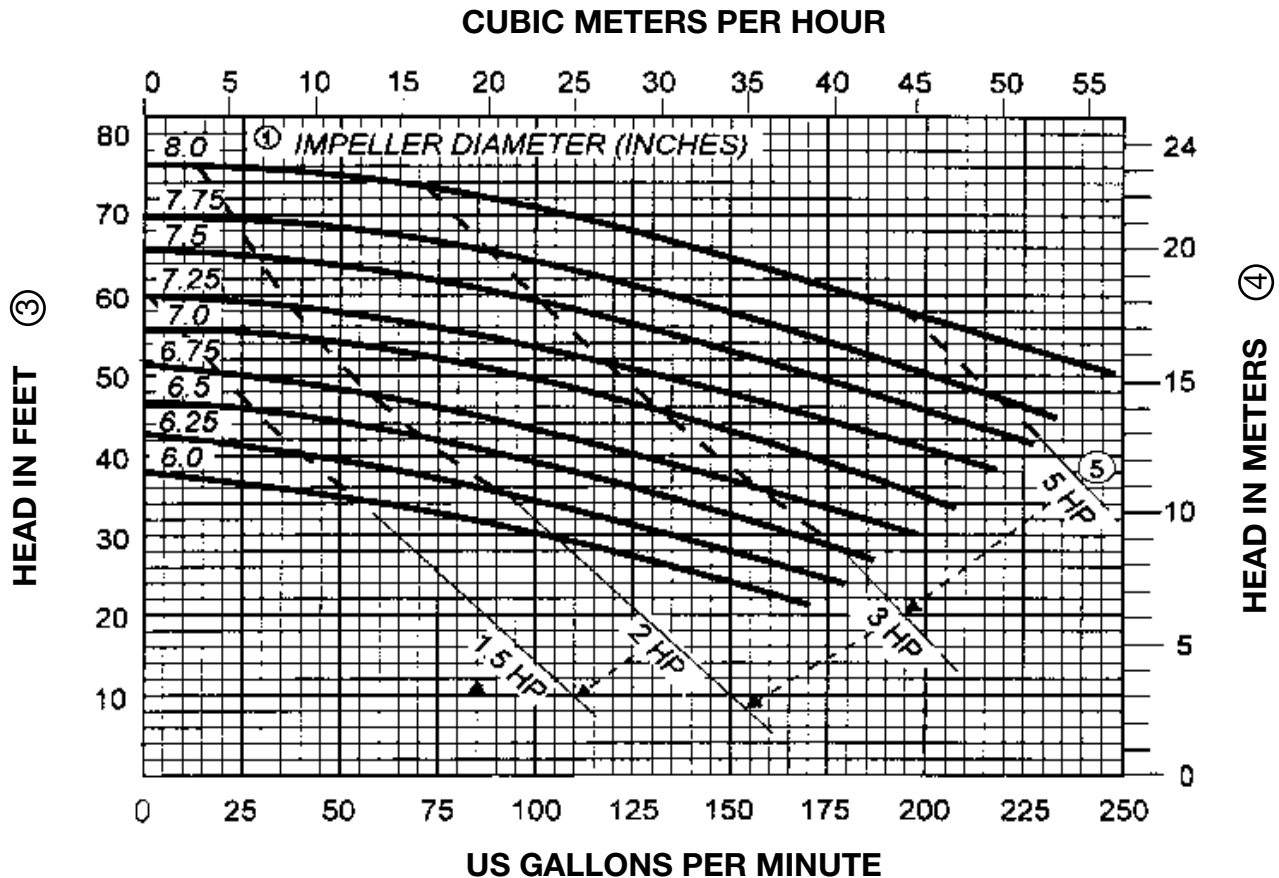

**NOTES:**

- ① Impeller diameters available in 1/16-inch increments
- ② NPSHR is shown for maximum impeller diameter
- ③  $PSI = \frac{\text{Head in Feet} \times \text{Specific Gravity}}{2.3}$
- ④  $Kg/cm^2 = \frac{\text{Head in Meters} \times \text{Specific Gravity}}{10}$
- ⑤  $HP \times 0.746 = Kw$

Office: P.O. Box 264 • Bradford, PA 16701  
 Plant: 21 Valley Hunt Drive • Lewis Run, PA 16738  
 Phone: 800-458-6095 • 814-362-4626 • FAX 814-362-4453



# TOP-FLO® TF-C Series Centrifugal

## Capacity Curves

Based on water at 70°F (22°C)

Model: C328

60 Hz

1750 RPM

Size: 3 x 2 x 8

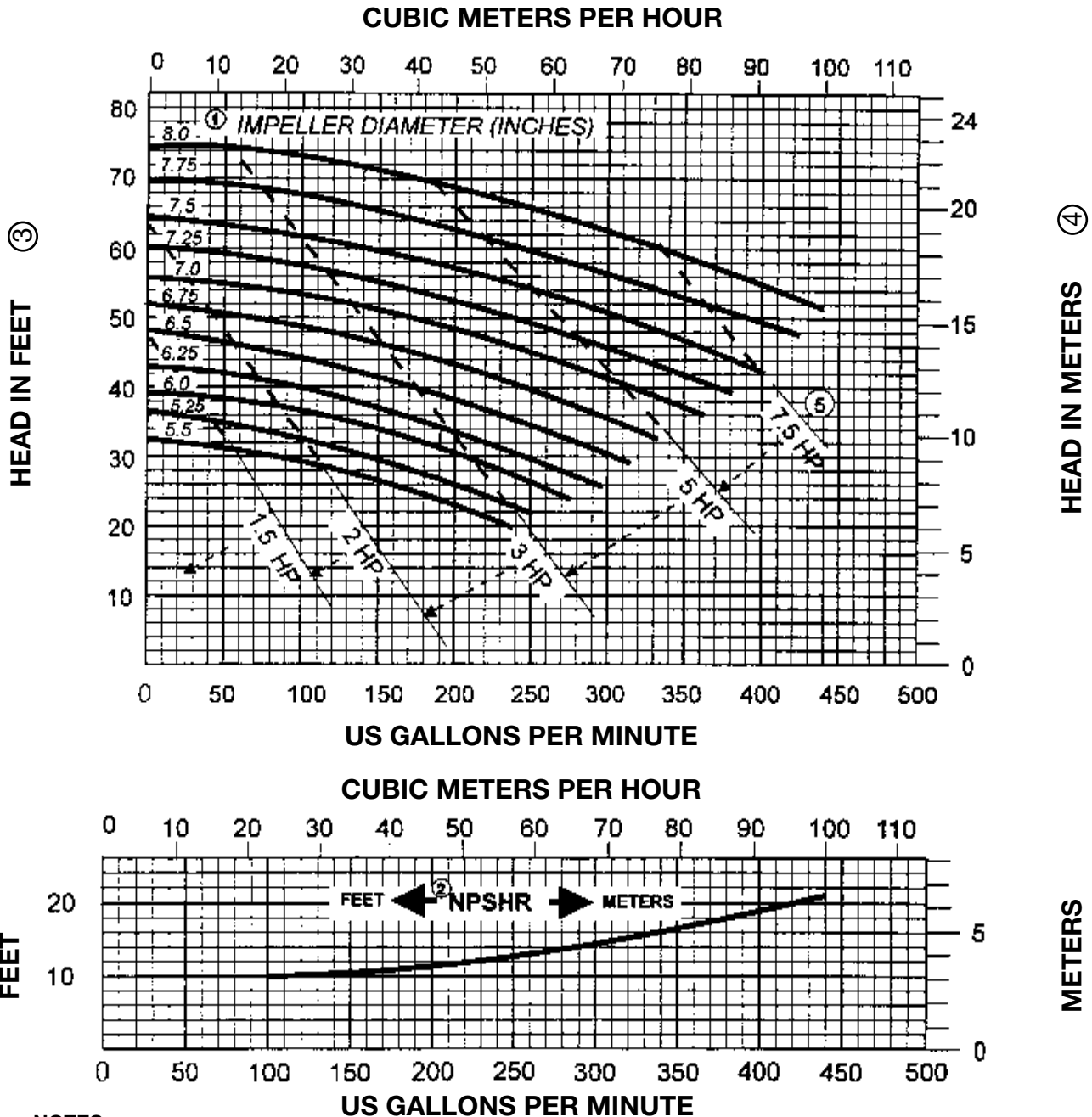

**NOTES:**

- ① Impeller diameters available in 1/4-inch increments
- ② NPSHR is shown for maximum impeller diameter
- ③  $PSI = \frac{\text{Head in Feet} \times \text{Specific Gravity}}{2.3}$
- ④  $Kg/cm^2 = \frac{\text{Head in Meters} \times \text{Specific Gravity}}{10}$
- ⑤  $HP \times 0.746 = Kw$

Office: P.O. Box 264 • Bradford, PA 16701  
 Plant: 21 Valley Hunt Drive • Lewis Run, PA 16738  
 Phone: 800-458-6095 • 814-362-4626 • FAX 814-362-4453



# TOP-FLO® TF-C Series Centrifugal

## Capacity Curves

Based on water at 70°F (22°C)

Model: C328

60 Hz

1750 RPM

Size: 4 x 2 x 8

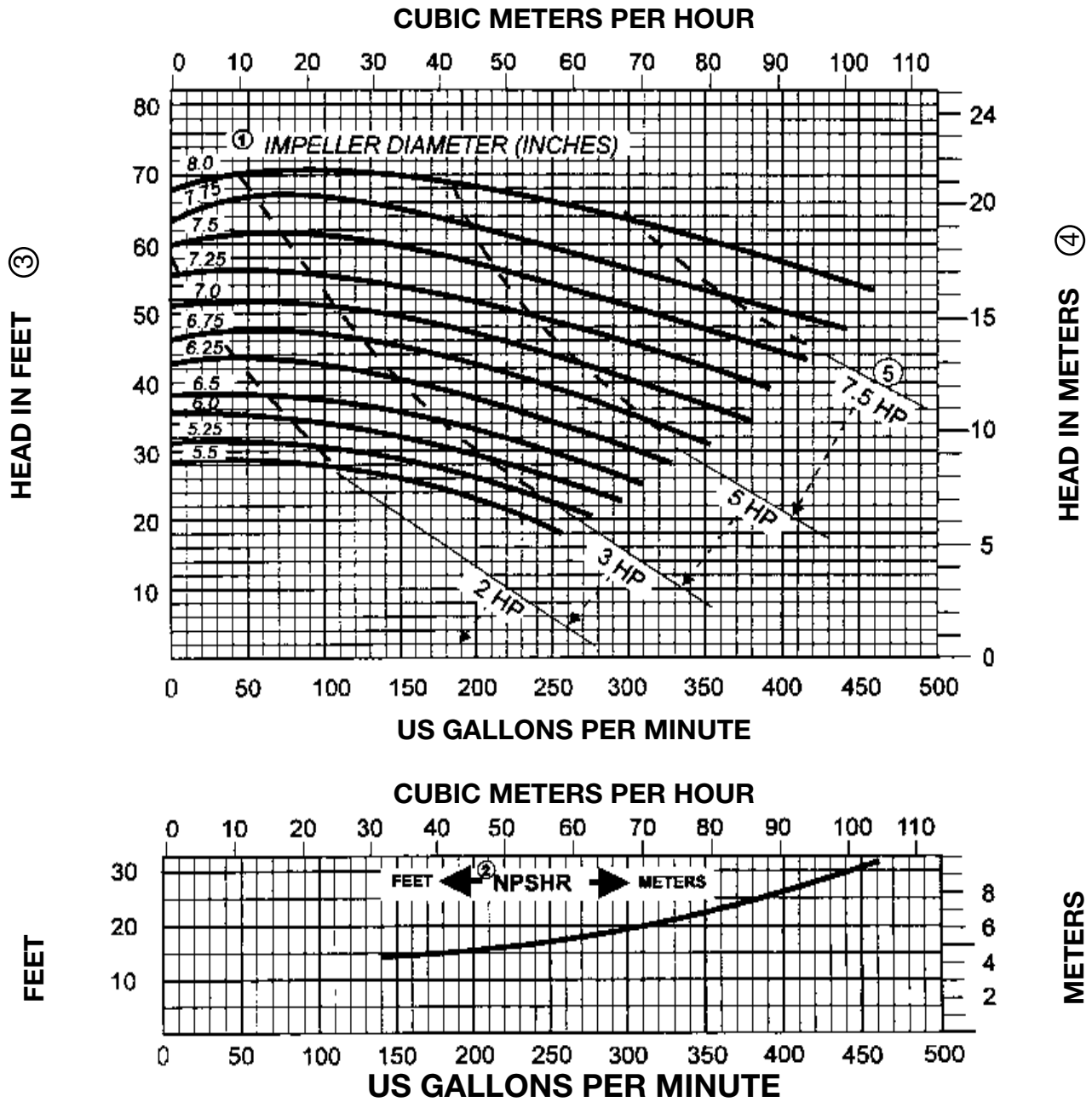

### NOTES:

① Impeller diameters available in 1/4-inch increments

② NPSHR is shown for maximum impeller diameter

③  $PSI = \frac{\text{Head in Feet} \times \text{Specific Gravity}}{2.3}$

④  $Kg/cm^2 = \frac{\text{Head in Meters} \times \text{Specific Gravity}}{10}$

⑤  $HP \times 0.746 = Kw$

Office: P.O. Box 264 • Bradford, PA 16701  
 Plant: 21 Valley Hunt Drive • Lewis Run, PA 16738  
 Phone: 800-458-6095 • 814-362-4626 • FAX 814-362-4453

**TOP LINE**  
 PROCESS EQUIPMENT COMPANY

# TOP-FLO® TF-C Series Centrifugal

## Capacity Curves

Based on water at 70°F (22°C)

Model: C100

60 Hz

3500 RPM

Size: 1-1/2 x 1 x 3-11/16

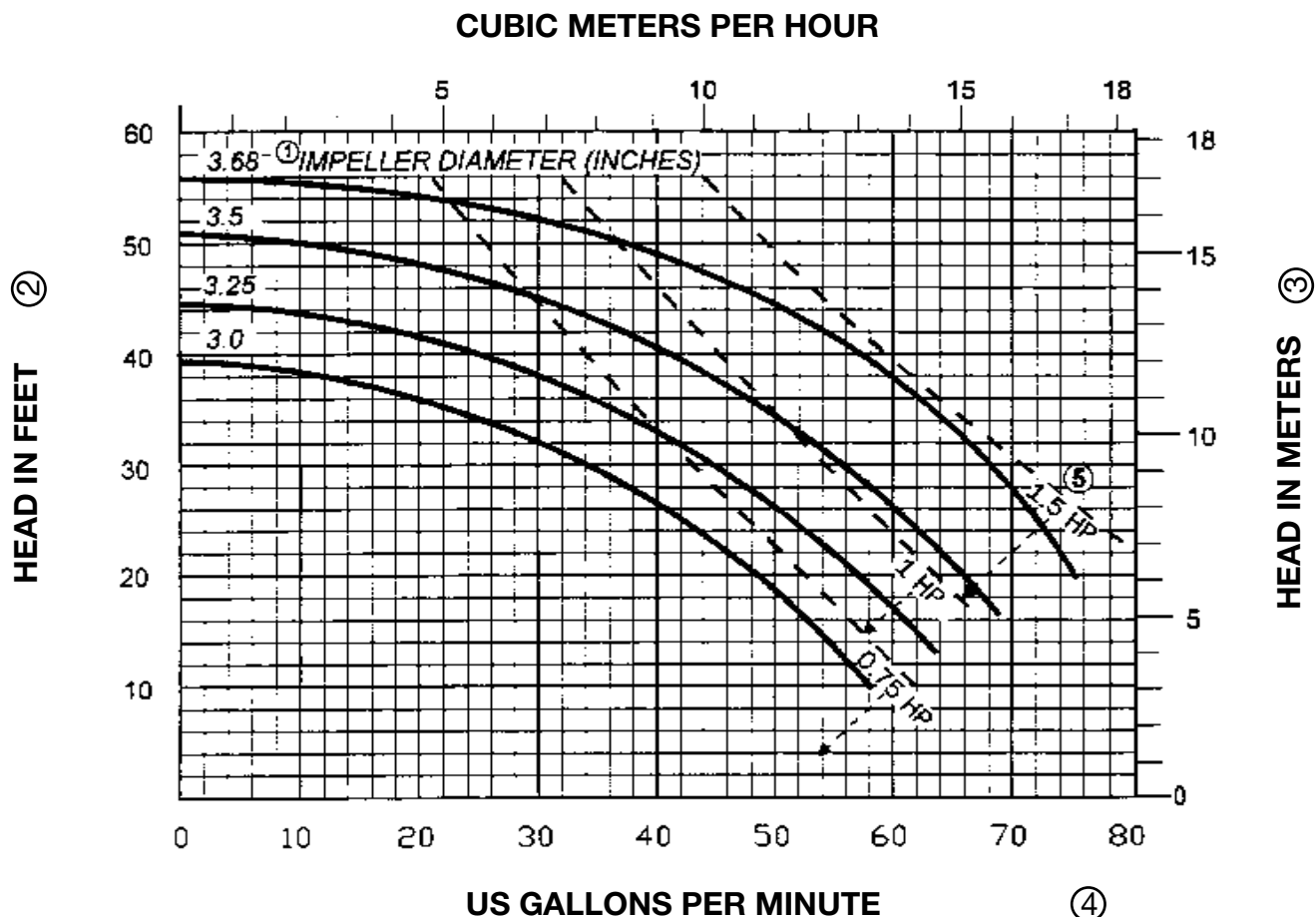

- NOTES:**
- ① Impeller diameters available in 1/16-inch increments
  - ②  $PSI = \frac{\text{Head in Feet} \times \text{Specific Gravity}}{2.3}$

- ③  $Kg/cm^2 = \frac{\text{Head in Meters} \times \text{Specific Gravity}}{10}$
- ④  $HP \times 0.746 = Kw$

Office: P.O. Box 264 • Bradford, PA 16701  
 Plant: 21 Valley Hunt Drive • Lewis Run, PA 16738  
 Phone: 800-458-6095 • 814-362-4626 • FAX 814-362-4453

**TOP LINE**  
 PROCESS EQUIPMENT COMPANY

# TOP-FLO® TF-C Series Centrifugal

## Capacity Curves

Based on water at 70°F (22°C)

Model: C114

60 Hz

3500 RPM

Size: 1-1/2 x 1-1/2 x 4

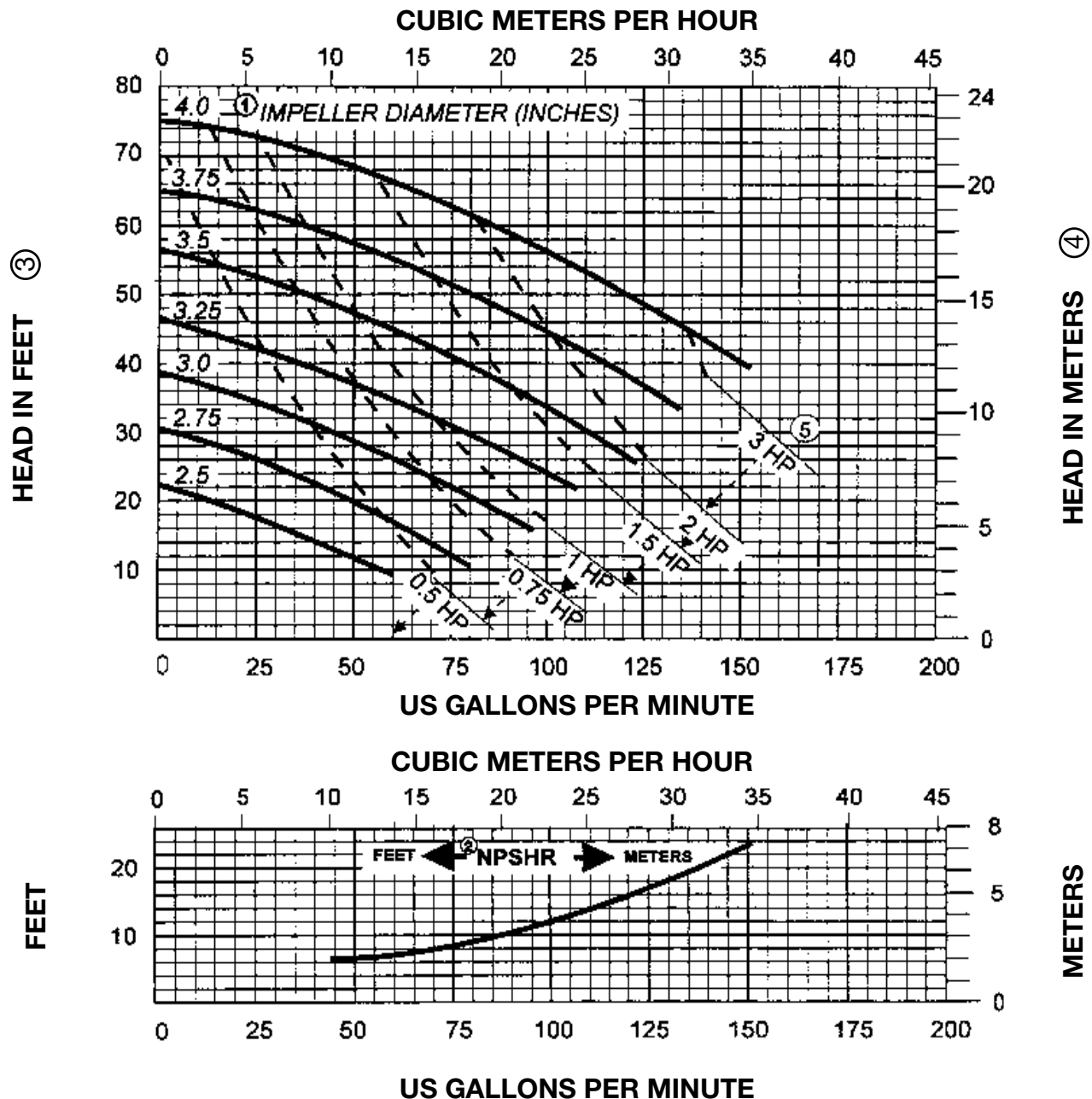

### NOTES:

① Impeller diameters available in 1/4-inch increments

② NPSHR is shown for maximum impeller diameter

③  $PSI = \frac{\text{Head in Feet} \times \text{Specific Gravity}}{2.3}$

④  $Kg/cm^2 = \frac{\text{Head in Meters} \times \text{Specific Gravity}}{10}$

⑤  $HP \times 0.746 = Kw$

Office: P.O. Box 264 • Bradford, PA 16701  
 Plant: 21 Valley Hunt Drive • Lewis Run, PA 16738  
 Phone: 800-458-6095 • 814-362-4626 • FAX 814-362-4453

**TOP LINE**  
 PROCESS EQUIPMENT COMPANY

# TOP-FLO® TF-C Series Centrifugal

## Capacity Curves

Based on water at 70°F (22°C)

Model: C114

60 Hz

3500 RPM

Size: 2 x 1-1/2 x 4

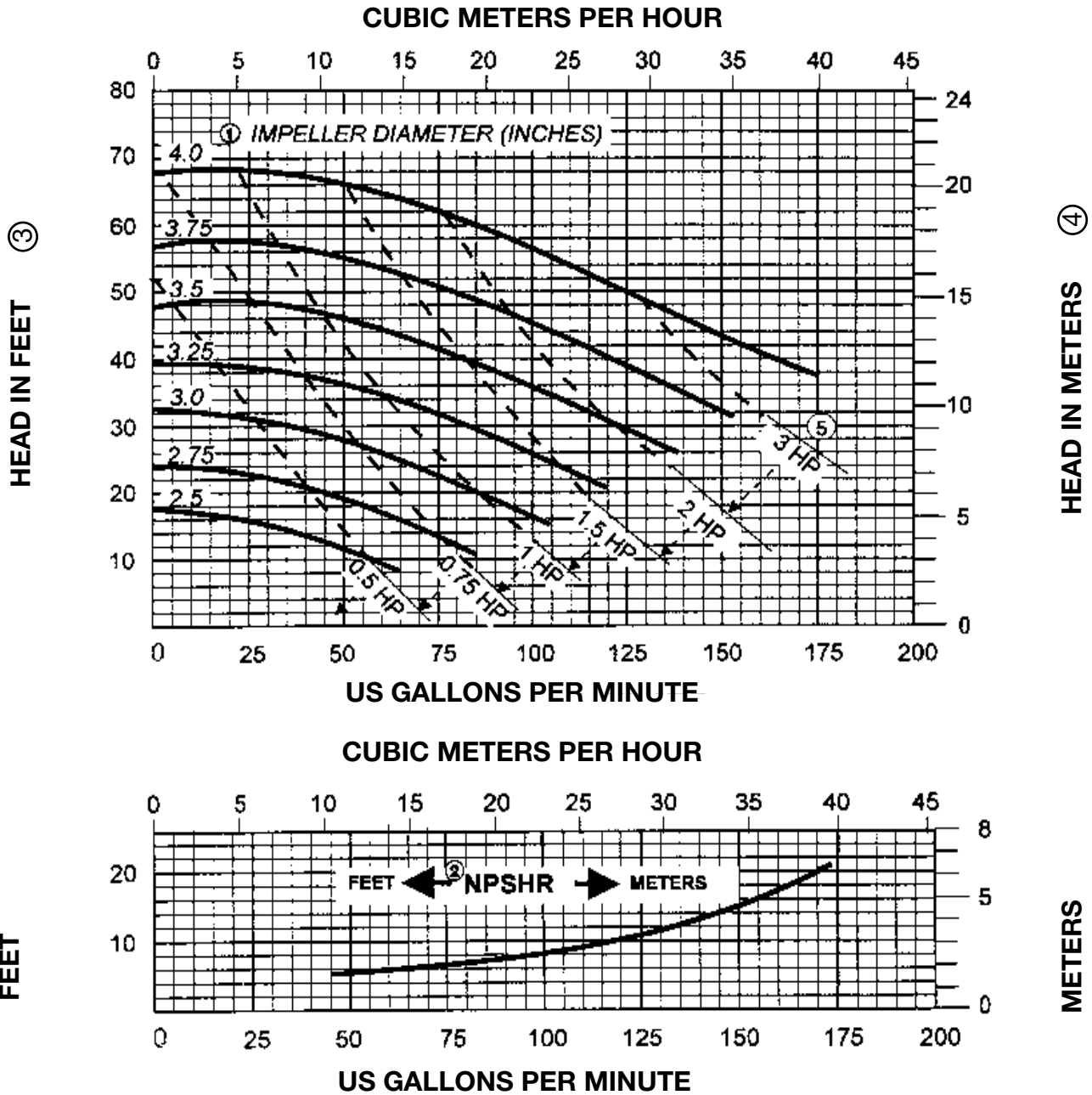

**NOTES:**

- ① Impeller diameters available in 1/4-inch increments
- ② NPSHR is shown for maximum impeller diameter
- ③  $PSI = \frac{\text{Head in Feet} \times \text{Specific Gravity}}{2.3}$
- ④  $Kg/cm^2 = \frac{\text{Head in Meters} \times \text{Specific Gravity}}{10}$
- ⑤  $HP \times 0.746 = Kw$

Office: P.O. Box 264 • Bradford, PA 16701  
 Plant: 21 Valley Hunt Drive • Lewis Run, PA 16738  
 Phone: 800-458-6095 • 814-362-4626 • FAX 814-362-4453



# TOP-FLO® TF-C Series Centrifugal

## Capacity Curves

Based on water at 70°F (22°C)

Model: C216

60 Hz

3500 RPM

Size: 2 x 1-1/2 x 6

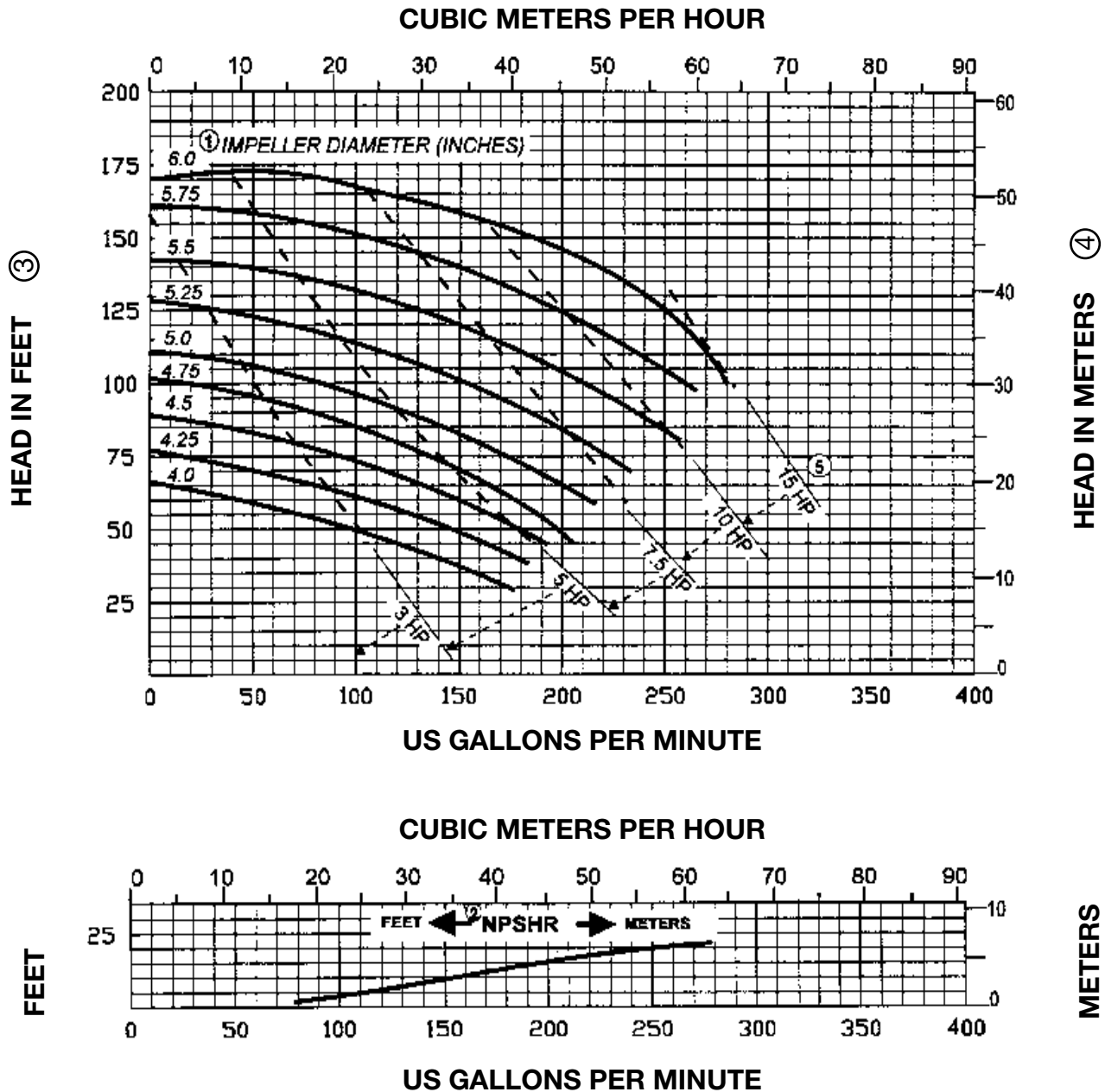

**NOTES:**

① Impeller diameters available in 1/4-inch increments

② NPSHR is shown for maximum impeller diameter

③  $PSI = \frac{\text{Head in Feet} \times \text{Specific Gravity}}{2.3}$

④  $Kg/cm^2 = \frac{\text{Head in Meters} \times \text{Specific Gravity}}{10}$

⑤  $HP \times 0.746 = Kw$

Office: P.O. Box 264 • Bradford, PA 16701  
 Plant: 21 Valley Hunt Drive • Lewis Run, PA 16738  
 Phone: 800-458-6095 • 814-362-4626 • FAX 814-362-4453

**TOP LINE**  
 PROCESS EQUIPMENT COMPANY

# TOP-FLO® TF-C Series Centrifugal

## Capacity Curves

Based on water at 70°F (22°C)

Model: C114

60 Hz

3500 RPM

Size: 2-1/2 x 1-1/2 x 6

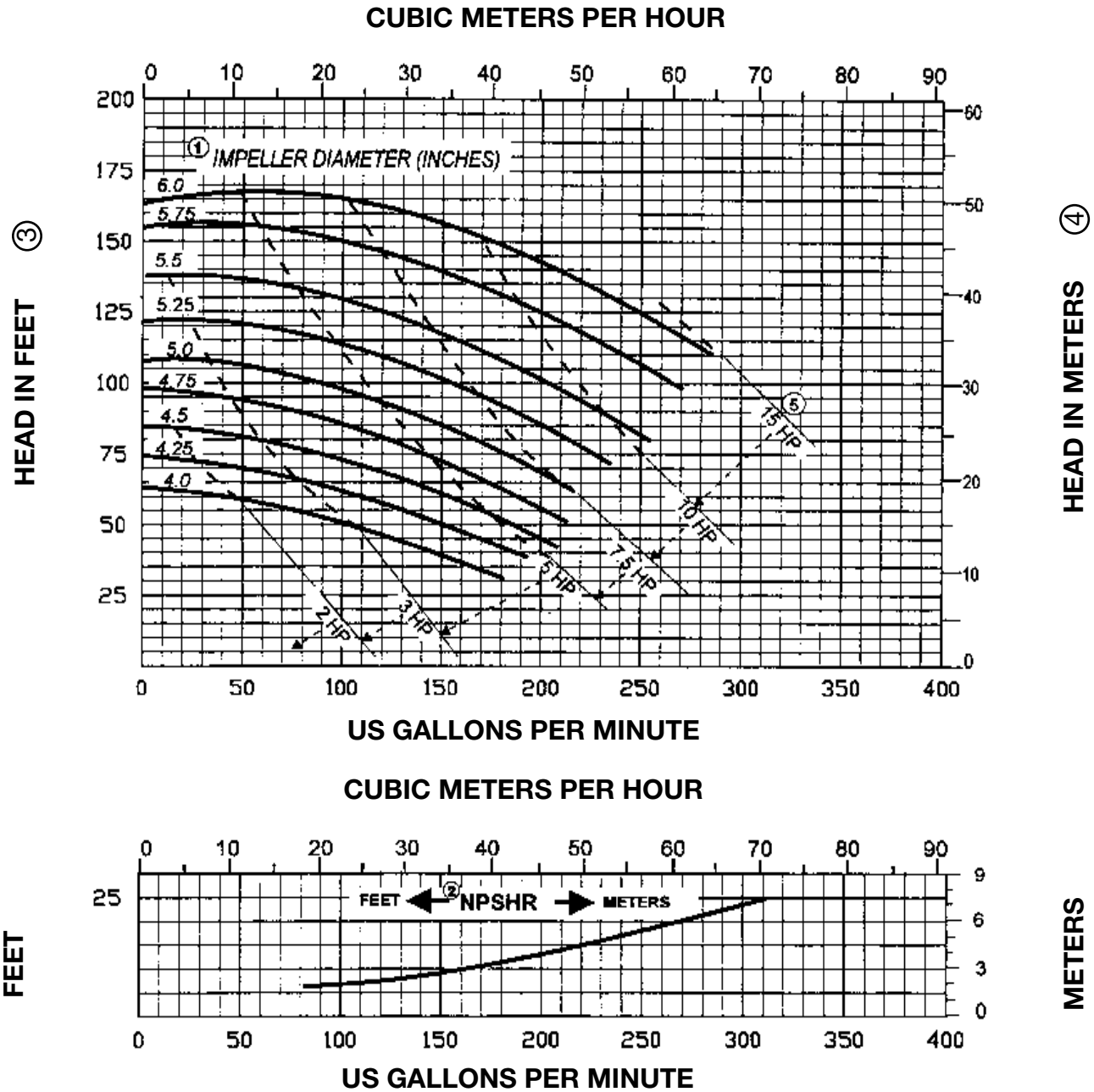

**NOTES:**

- ① Impeller diameters available in 1/4-inch increments
- ② NPSHR is shown for maximum impeller diameter
- ③  $PSI = \frac{\text{Head in Feet} \times \text{Specific Gravity}}{2.3}$

- ④  $Kg/cm^2 = \frac{\text{Head in Meters} \times \text{Specific Gravity}}{10}$
- ⑤  $HP \times 0.746 = Kw$

Office: P.O. Box 264 • Bradford, PA 16701  
 Plant: 21 Valley Hunt Drive • Lewis Run, PA 16738  
 Phone: 800-458-6095 • 814-362-4626 • FAX 814-362-4453



# TOP-FLO<sup>®</sup> TF-C Series Centrifugal

## Capacity Curves

Based on water at 70°F (22°C)

Model: C218

60 Hz

3500 RPM

Size: 2 x 1-1/2 x 8

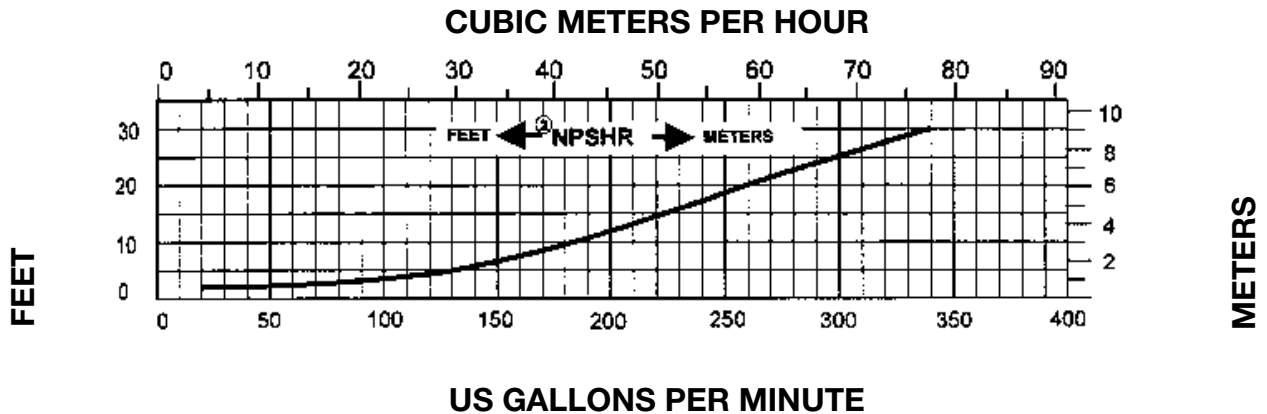
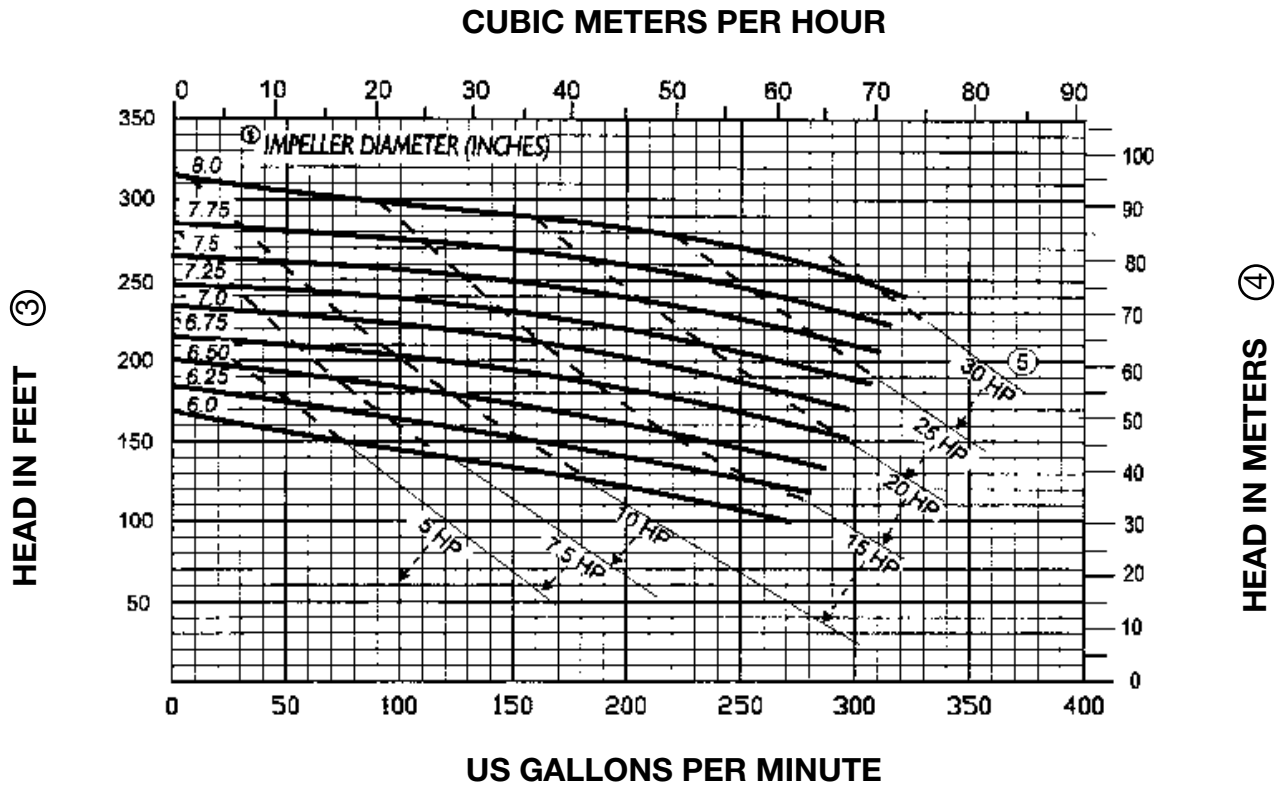

**NOTES:**

- ① Impeller diameters available in 1/4-inch increments
- ② NPSHR is shown for maximum impeller diameter
- ③  $PSI = \frac{\text{Head in Feet} \times \text{Specific Gravity}}{2.3}$
- ④  $Kg/cm^2 = \frac{\text{Head in Meters} \times \text{Specific Gravity}}{10}$
- ⑤  $HP \times 0.746 = Kw$

Office: P.O. Box 264 • Bradford, PA 16701  
 Plant: 21 Valley Hunt Drive • Lewis Run, PA 16738  
 Phone: 800-458-6095 • 814-362-4626 • FAX 814-362-4453



# TOP-FLO® TF-C Series Centrifugal

## Capacity Curves

Based on water at 70°F (22°C)

Model: C218

60 Hz

3500 RPM

Size: 3 x 1-1/2 x 8

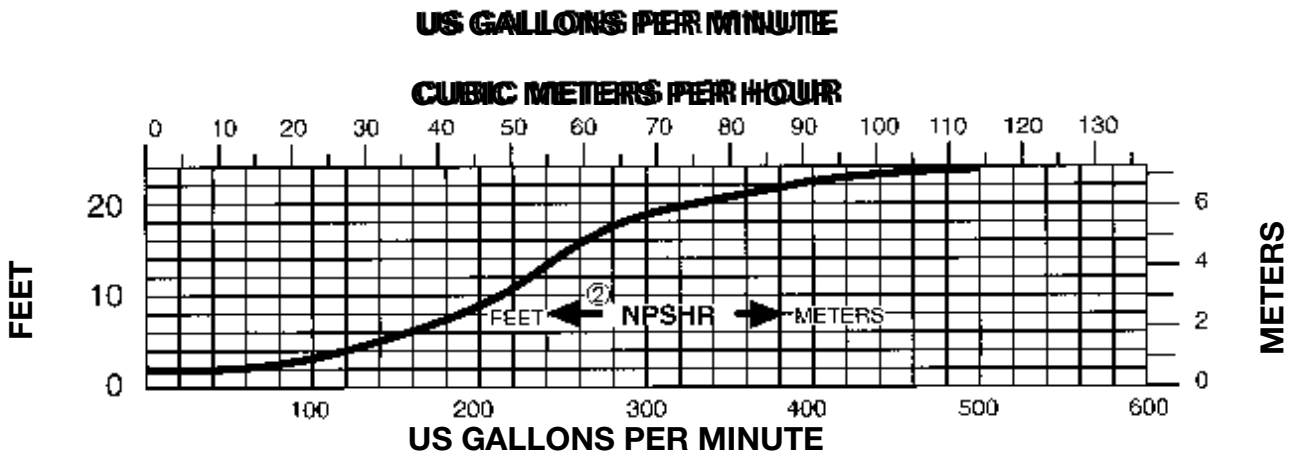
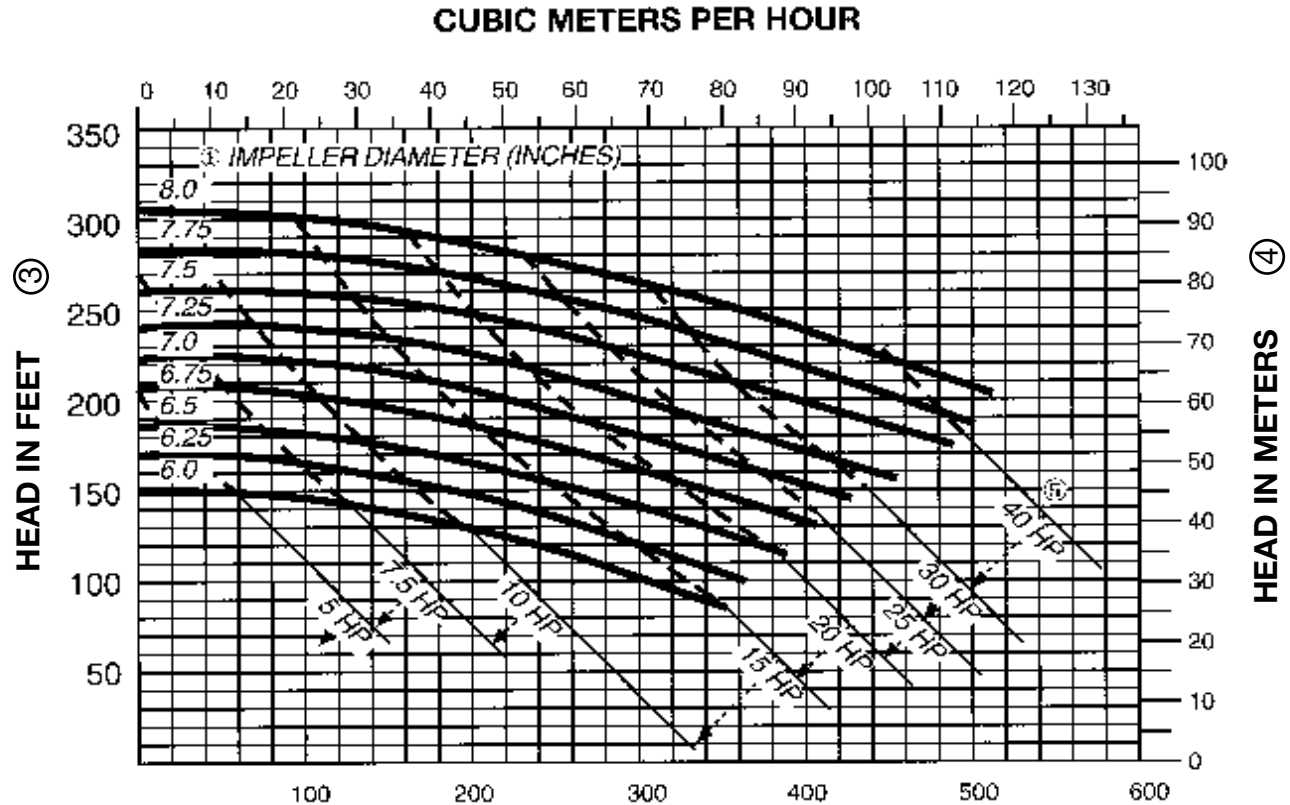

### NOTES:

① Impeller diameters available in 1/4-inch increments

② NPSHR is shown for maximum impeller diameter

③  $PSI = \frac{\text{Head in Feet} \times \text{Specific Gravity}}{2.3}$

④  $Kg/cm^2 = \frac{\text{Head in Meters} \times \text{Specific Gravity}}{10}$

⑤  $HP \times 0.746 = Kw$

Office: P.O. Box 264 • Bradford, PA 16701  
 Plant: 21 Valley Hunt Drive • Lewis Run, PA 16738  
 Phone: 800-458-6095 • 814-362-4626 • FAX 814-362-4453

**TOP LINE**  
 PROCESS EQUIPMENT COMPANY

# TOP-FLO® TF-C Series Centrifugal

## Capacity Curves

Based on water at 70°F (22°C)

Model: C328

60 Hz

3500 RPM

Size: 3 x 2 x 8

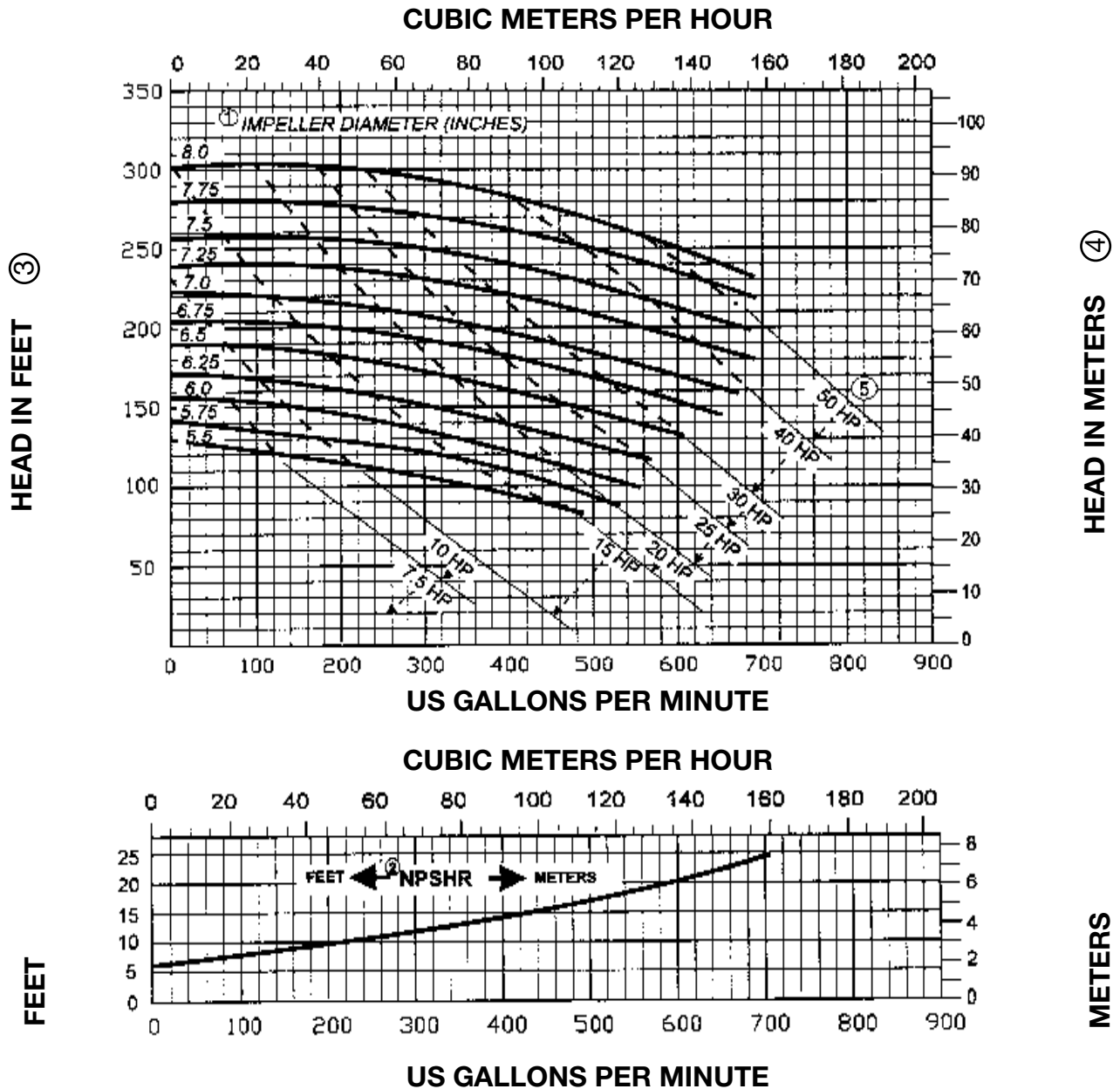

### NOTES:

① Impeller diameters available in 1/4-inch increments

② NPSHR is shown for maximum impeller diameter

③  $PSI = \frac{\text{Head in Feet} \times \text{Specific Gravity}}{2.3}$

④  $Kg/cm^2 = \frac{\text{Head in Meters} \times \text{Specific Gravity}}{10}$

⑤  $HP \times 0.746 = Kw$

Office: P.O. Box 264 • Bradford, PA 16701  
 Plant: 21 Valley Hunt Drive • Lewis Run, PA 16738  
 Phone: 800-458-6095 • 814-362-4626 • FAX 814-362-4453

**TOP LINE**  
 PROCESS EQUIPMENT COMPANY

# TOP-FLO® TF-C Series Centrifugal

## Capacity Curves

Based on water at 70°F (22°C)

Model: C328

60 Hz

3500 RPM

Size: 4 x 2 x 8

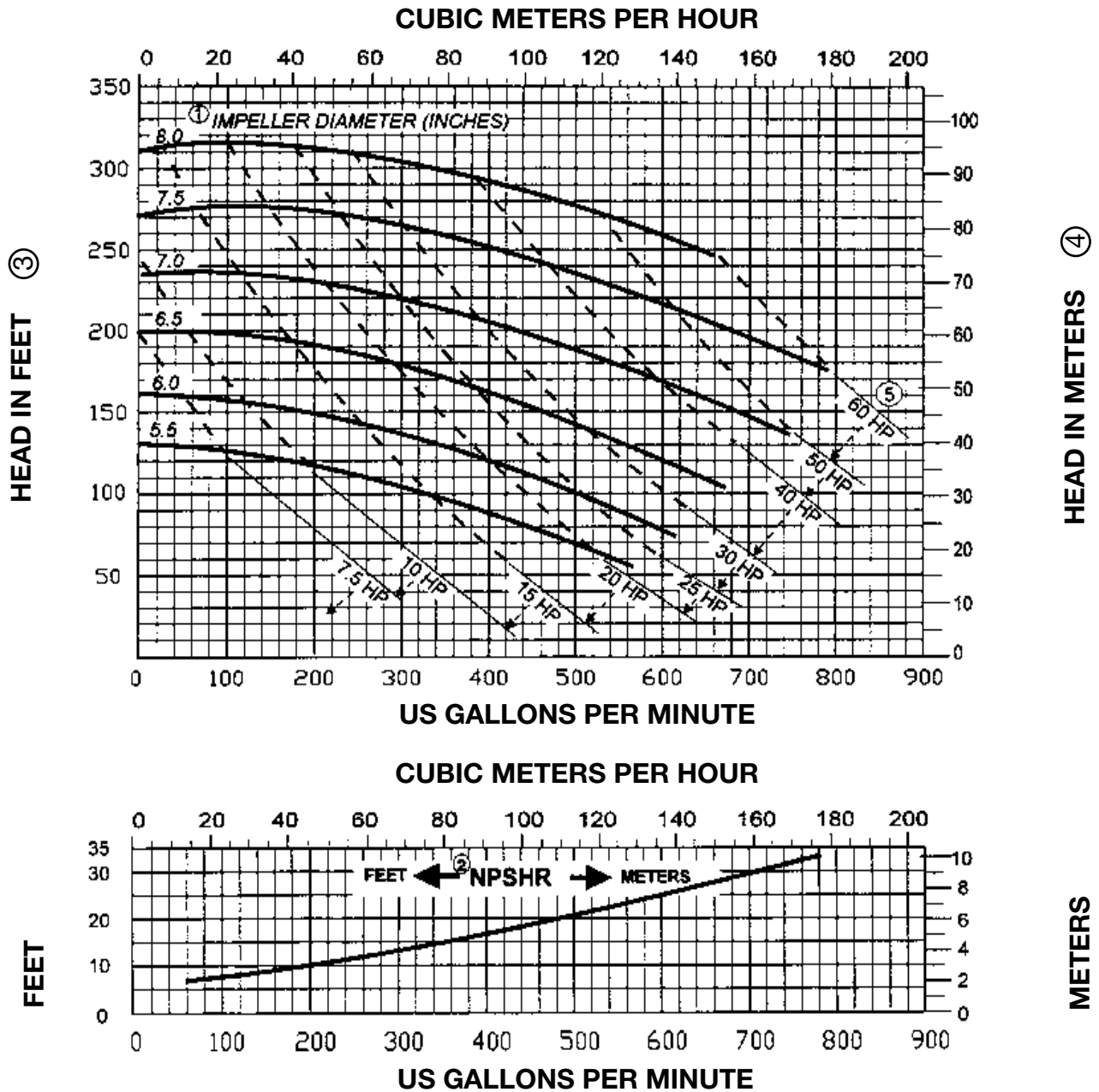

### NOTES:

① Impeller diameters available in 1/4-inch increments

④  $\text{Kg/cm}^2 = \frac{\text{Head in Meters} \times \text{Specific Gravity}}{10}$

② NPSHR is shown for maximum impeller diameter

⑤  $\text{HP} \times 0.746 = \text{Kw}$

③  $\text{PSI} = \frac{\text{Head in Feet} \times \text{Specific Gravity}}{2.3}$

Office: P.O. Box 264 • Bradford, PA 16701  
 Plant: 21 Valley Hunt Drive • Lewis Run, PA 16738  
 Phone: 800-458-6095 • 814-362-4626 • FAX 814-362-4453

**TOP LINE**  
 PROCESS EQUIPMENT COMPANY

# Viscosity and Specific Gravity Table for Various Products

Product	Specific Gravity	Viscosity
Acetic Acid		
5%	1.01	
10%	1.01	31.7 SSU @ 59° F
50%	1.06	33 SSU @ 59° F
80%	1.08	35 SSU @ 59° F
Animal Fat	0.9	130 SSU @ 115° F 50 SSU @ 200° F
Barbecue Sauce	1.05	11,500 SSU @ 40-75° F
F		
Beer	1.02	32 SSU @ 68° F
Blood - Animal	.93-.98	15,000 SSU @ 55° F
Butter	.93-.98	15,000 SSU @ 55° F 440 SSU @ 90° F 220 SSU @ 115° F
Coconut Oil	0.92	125 SSU @ 106° F
Corn Oil	0.92	135 SSU @ 130° F 54 SSU @ 212° F
Corn Starch Solutions		
22 Baume	1.18	150 SSU @ 70° F 130 SSU @ 100° F
24 Baume	1.2	600 SSU @ 70° F 440 SSU @ 100° F
25 Baume	1.21	1400 SSU @ 70° F 800 SSU @ 100° F
Cottage Cheese	1.02	4,300 SSU
Dressing		
Cream (Sweet)	1	73 SSU
	.99	140 SSU
	.99	215 SSU
Egg Yolk	1.12	21,500 @ 35° F
Gelatin	1.01	1,380 - 2,580 SSU @ 160° F
Glucose	1.35 - 1.44	35M - 100M SSU @ 100° F

Product	Specific Gravity	Viscosity
Honey	1.3	1250 - 1425 SSU @ 100° F
Ice Cream Mix	1.15	1050 SSU @ ° F
Lard	0.96	287 @ 100° F
Linseed Oil	.92-.94	143 @ 100° F 93 @ 130° F
Malt Syrup	1.41	85,400 SSU @ 77° F
Maple Syrup	1.37	2,000 SSU @ ° F
Margarine	0.93	13,900 SSU @ 84° F
Milk	1.02 - 1.05	31.5 @ 68° F
Molasses		
A. First	1.4 - 1.46	1300 - 23,500 SSU @ 100° F 700 - 8160 SSU @ 130° F
B. Second	1.43 - 1.48	6535 - 61,180 SSU @ 100° F 3058 - 15294 SSU @ 130° F
C. Blackstrap	1.46 - 1.49	12,190 - 255M @ 100° F
Mustard	1	17,000 SSU @ 85° F
Olive Oil	.91 - .92	200 SSU @ 100° F
Peanut Butter	1.2	77,400 SSU @ 110 - 140° F
Sesame Seed Oil	0.92	184 SSU @ 100° F 110 @ 130° F
Soy Bean Oil	0.91	500 SSU @ 44° F
Tomato Paste	1.14	60M - 80 M SSU 21M SSU approx.
Water	1	31 SSU @ 68° F

# How Capacity Affects Friction

The following table was developed to indicate loss of head due to friction – in feet loss per fitting or in feet loss per foot of tubing – through stainless steel tubing and sanitary fittings.

## Friction Loss in Sanitary OD Tubing and Fittings

Capacity in U.S. G.P.M.	O.D. Tube Size																	
	1" I.D.=.870"			1-1/2" I.D.=1.370"			2" I.D.=1.870"			2-1/2" I.D.=2.370"			3" I.D.=2.870"			4" I.D.=3.834"		
	Tubing	Elbow	Tee	Tubing	Elbow	Tee	Tubing	Elbow	Tee	Tubing	Elbow	Tee	Tubing	Elbow	Tee	Tubing	Elbow	Tee
2	.01	.01	.1															
4	.025	.02	.2															
5	.035	.025	.25															
10	.12	.06	.4	.02	.01	.15	.005	.015	.1									
15	.25	.1	.8	.04	.02	.25	.013	.02	.15									
20	.43	.22	1.5	.06	.03	.3	.02	.025	.2	.005	.02	.1	.003	.02	.06			
25	.66	.4	2.3	.08	.04	.4	.025	.03	.25	.006	.03	.15	.004	.03	.08			
30	.93	.7	3.3	.105	.06	.55	.035	.05	.3	.008	.05	.2	.005	.04	.1			
35	1.22	1.25	5.2	.135	.09	.8	.04	.06	.4	.011	.06	.25	.006	.05	.13			
40				.17	.11	1.0	.05	.08	.5	.015	.07	.3	.007	.06	.15			
45				.21	.16	1.3	.063	.1	.6	.02	.09	.35	.008	.065	.18			
50				.25	.2	1.6	.073	.12	.7	.022	.1	.4	.01	.07	.2			
60				.34	.35	2.2	.1	.18	.9	.03	.12	.45	.015	.08	.25			
80				.57	.76	3.7	.16	.3	1.5	.05	.15	.55	.02	.1	.4			
100				.85	1.35	5.8	.23	.44	2.3	.075	.18	.6	.03	.11	.5	.008	.04	.1
120				1.18	2.05	9.1	.32	.64	3.3	.105	.21	1.0	.04	.13	.6	.01	.05	.15
140							.42	.85	4.5	.14	.23	1.25	.05	.16	.8	.013	.06	.2
160							.54	1.13	5.8	.17	.28	1.6	.07	.2	1.1	.015	.07	.25
180							.67	1.45	7.4	.205	.31	2.0	.08	.21	1.3	.02	.08	.3
200							.81	1.82	9.0	.245	.35	2.5	.1	.26	1.6	.025	.09	.4
220							.95	2.22	11.0	.29	.41	3.0	.12	.3	1.9	.028	.1	.5
240							1.10	2.63	13.5	.34	.48	3.7	.14	.33	2.2	.035	.11	.55
260										.39	.53	4.5	.165	.39	2.5	.04	.115	.6
280										.45	.61	5.3	.19	.42	2.8	.045	.12	.65
300										.515	.7	6.2	.22	.5	3.1	.05	.13	.7
350										.68	1.05	8.5	.28	.67	4.1	.07	.15	.9
400										.86	1.55	11.0	.36	.88	5.2	.085	.18	1.2
450										1.05	2.25	13.5	.44	1.1	6.6	.105	.2	1.5
500													.54	1.4	8.0	.13	.23	1.75
550													.64	1.7	9.5	.15	.27	2.1
600													.75	2.05	10.2	.175	.3	2.5
650													.87	2.41	13.0	.2	.34	2.8
700													1.0	2.8	15.0	.23	.4	3.4
750																.26	.43	3.8
800																.3	.5	4.4
850																.33	.56	5.
900																.37	.62	5.7
950																.41	.7	6.3
1000																.45	.8	7.0
1100																.53	1.06	8.6

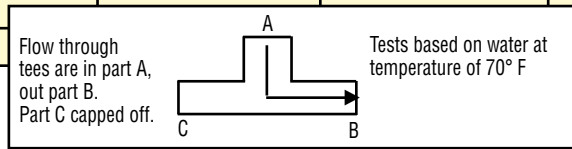

Source: National Association of Food and Dairy Equipment Manufacturers.

# TOP-FLO® TF-C Series Close-Coupled Pump Dimensions

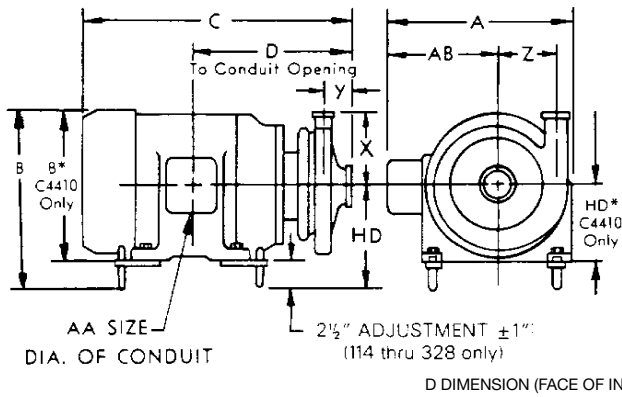

180 to 280 Frame Motors

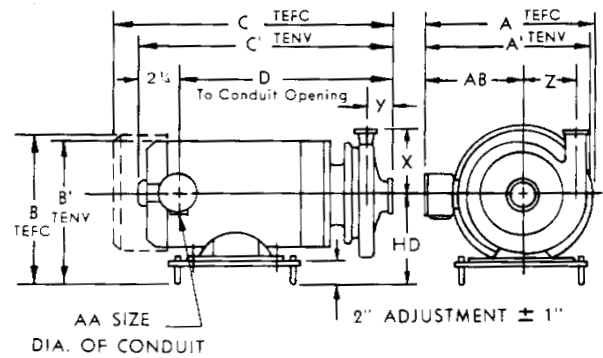

56 and 140 Frame Motors

## Pump Dimensions ("Easy-Clean" totally-enclosed motor)

Pump Model	Suction	Discharge	X*	X**	Y*	Y**	Z
TF-C114	1-1/2	1-1/2	3-5/8	3-7/8	1-19/32	1-27/32	2-5/8
TF-C216	2	1-1/2	4-1/2	4-3/4	1-29/32	1-5/32	3-11/16
TF-C218	2	1-1/2	5-1/2	5-3/4	1-23/32	1-31/32	4-3/4
TF-C328	3	2	5-1/2	5-3/4	2-7/32	2-23/32	4-3/4

## Pump and Motor Dimensions with "Easy-Clean" Totally Enclosed Motors

Pump Model	Frame	A	A'	B	B'	C*	C'*	C**	C'***	D*	D**	HD	AA	AB
TF-C114	56C	10-1/16	9-5/8	9-3/16	8-3/4	17-7/16	16-1/16	17-11/16	16-5/16	13-5/16	13-9/16	5-1/2	1/2	6-3/8
	184TC	11-7/8		11-11/16		21-1/8		21-3/8		13-13/16	14-1/16	7	3/4	7-3/16
TF-C216	56C	10-1/16	9-5/8	9-3/16	8-3/4	18-1/8	16-3/4	18-3/8	17	14	14-1/4	5-1/2	1/2	6-3/8
	184TC	11-7/8		11-11/16		21-7/8		22-1/8		14-9/16	14-13/16	7	3/4	7-3/16
	215TC	14-1/2		13-3/16		25-9/16		25-13/16		16-11/16	16-15/16	7-3/4	1	9-1/16
	256TC	16-7/16		15-1/4	29-15/16	30-3/16		18-11/16	18-15/16	8-3/4	1-1/4	10		
TF-C218	145TC	10-1/16	9-5/8	8-3/4	19-1/4	17-7/8	19-1/2	18-1/2	15-1/8	15-3/8	5-1/2	1/2	6-3/8	
	184TC	11-7/8		11-11/16		22-1/4		22-1/2		14-15/16	15-3/16	7	3/4	7-3/16
	215TC	14-1/2		13-3/16		25-13/16		26-1/16	16-15/16	17-3/16	7-3/4	1	9-1/16	10
	256TC	16-7/16		15-1/4		31-1/16		31-5/16		19-13/16	20-1/16	8-3/4	1-1/4	10
	284TC	19-5/16	16-3/4	32	32-1/4	20-3/16	20-7/16	9-1/2	1-1/2	12-1/16				
TF-C328	145TC	10-1/16	9-5/8	9-3/16	8-3/4	19-7/8	18-1/2	20-3/8	19	15-3/4	16-1/4	15-1/2	1/2	6-3/8
	184TC	11-7/8		11-11/16		22-3/4		23-1/4		15-7/16	15-15/16	7	3/4	7-3/16
	215TC	14-1/2		13-3/16		26-5/16		26-13/16		17-7/16	17-15/16	7-3/4	1	9-1/16
	256TC	16-7/16		15-1/4		31-11/16		32-3/16		20-7/16	20-15/16	8-3/4	1-1/4	10
	284TC	19-5/16		16-3/4		32-5/8		33-1/8		20-13/16	21-5/16	9-1/2	1-1/2	12-1/16
	286TC	19-5/16		16-3/4		34-3/8		34-7/8		21-13/16	22-5/16	9-1/2	1-1/2	12-1/16

\* With clamp connections  
\*\* With threaded bevel-seat connections

Dimensions are appropriate and for guidance only. ON applications where exact dimensions are required, request a certified print from Top Line.

NOTES: 1 - Dimensions for single phase #140 frame motors 1-7/32" longer.

\* - These dimensions are for pumps using standard "C" Flange Motors \* - TF-C Series pumps will not accept TSC Frame Motors.

# Notes

# Notes





Customer \_\_\_\_\_ Contact \_\_\_\_\_ Date \_\_\_\_\_

### I. Sizing Data Required

Product \_\_\_\_\_ Temperature: \_\_\_\_\_ Min. ° F \_\_\_\_\_ Max. ° F  
Viscosity (Centipoise) \_\_\_\_\_ Product Weight \_\_\_\_\_ (pounds per gallon)  
Gallons Per Minute \_\_\_\_\_ Total Head \_\_\_\_\_ ft. \_\_\_\_\_ psi  
Pounds Per Hour \_\_\_\_\_  
Corrosive Material:  Yes  No  Type \_\_\_\_\_

### Suction Line

Tubing Size \_\_\_\_\_ inches Total Elbows \_\_\_\_\_  
Vertical Drop \_\_\_\_\_ feet Total Tees \_\_\_\_\_  
Casing Drain:  Yes  No Total Valves \_\_\_\_\_  
Corrosive Material:  Yes  No  Type \_\_\_\_\_

### Discharge Line

Tubing Size \_\_\_\_\_ Total Elbows \_\_\_\_\_  
Vertical Run \_\_\_\_\_ Total Tees \_\_\_\_\_  
Horizontal Run \_\_\_\_\_ Total Valves \_\_\_\_\_  
Note: Clamp connections are standard. If other connection is required, specify. \_\_\_\_\_  
Discharge Valve: Butterfly \_\_\_\_\_ Ball \_\_\_\_\_ Disc Check \_\_\_\_\_ Other \_\_\_\_\_

If Top Line supplies pump motor, the following data is required:

Voltage \_\_\_\_\_ Hertz \_\_\_\_\_ Phase \_\_\_\_\_

### II. Fill out the following after pump and motor are sized

Pump:	Motor:
Model _____	Type _____
Casing Size _____	Horsepower _____
Impeller Size _____	RPM _____
Seal Type _____	Frame Size _____
Voltage _____ Hertz _____ Phase _____	

# TOP LINE

PROCESS EQUIPMENT COMPANY

. . . the source for  
all your product needs  
in the process industries

Contact your Top Line Representative for Assistance

Office: P.O. Box 264 · Bradford, PA 16701

Plant: 21 Valley Hunt Drive · Lewis Run, PA 16738

800-458-6095

814-362-4626

Fax: 814-362-4453

## PUMPS & STRAINERS- Centrifugal, Rotary Lobe, Filters and Strainers



## VALVES - Manual, Actuated, Diaphragm



## FITTINGS - Clamp, Sanitary Butt Weld, Bevel Seat, Tube OD Butt Weld, Custom, Biopharm



## TUBING, GAUGES, SIGHT GLASSES, BRAIDED HOSE



[www.toplineonline.com](http://www.toplineonline.com)