



VNE



Valves Product Catalog



	AFFILIATIONS	PAGE 1
	BUTTERFLY VALVES	PAGE 2-9
	Specifications.....	3
	Pneumatically Operated technical application data and dimensions.....	4
	Manual information and dimensional chart.....	5
	Manual parts drawing and parts list.....	6
	Electronically-controlled Pneumatically operated information & drawing.....	7
	Electronic Actuator part list & dimensional chart.....	8
	Pneumatically operated and electronically-controlled part number information.....	9
	CHECK VALVES	PAGE 10-17
	Specifications.....	11
	Ball Check information, parts breakdown & part number sequence for ordering.....	12
	Spring Check information, parts breakdown & part number sequence for ordering.....	13
	Air Blow Check illustration, parts list and connections.....	14
	Air Blow Check abilities and dimension table.....	15
	Air Blow Check Disposable Air Filter Media Capacity Test.....	16
	Air Blow Check on top of Check.....	17
	BALL VALVES	PAGE 18-21
	2 - Way Specifications.....	19
	2 - Way Clamp and Weld part numbers, illustrations and dimensions.....	20
	2 - Way Clamp and Weld part list, pressure temperature rating and torques.....	21
	3 - Way Specifications.....	22
	3 - Way Clamp part numbers, illustrations and dimensions.....	23
	3 - Way Weld part numbers, illustrations and dimensions.....	24
	3 - Way Clamp and Weld part list, pressure temperature rating and torques.....	25
	2 & 3 Way dimensions with Actuators	26
	3 - Way Ball Valve Configuration options (standard Actuator).....	27
	3 - Way Ball Valve Configuration options (reverse-acting Actuator).....	28
	2 & 3 Way Actuated Ball Valve part numbering	29
	PVA VALVES	PAGE 30-41
	Specifications.....	31
	Illustrations, part numbers, and dimensions.....	32
	Shut Off illustration & part number information.....	33
	Shut Off replacement parts.....	34
	Divert illustration & part number information.....	35
	Divert replacement parts.....	36
	Air Actuator control head and Actuator illustrations.....	37
	Air Actuator control top replacement parts and Air Actuator replacement parts.....	38
	Tank-Bottom illustration and parts.....	39
	Manual Actuator, Actuator, Actuator with control head illustrations & parts.....	40
	Pressure drop and capacity diagrams.....	41
	COMPRESSION VALVE	PAGE 42

VNE AFFILIATIONS...

VNE is an active member of numerous industry-related organizations and associations.

3-A®

VNE is a member of 3-A®, a voluntary organization committed to safeguarding public health and dairy product quality through a unique industry-regulated program of sanitary standards for equipment used in processing dairy foods.

WCMA

Wisconsin Cheese Makers Association

VNE is a member of WCMA, a nonprofit trade association dedicated to improving the business climate for dairy companies, primarily cheese and butter manufacturing and marketing companies. Their actions also extend to the companies that supply goods and services to the dairy industry.

FISA

Food Industry Suppliers Association

VNE is a member of FISA, a national association of independent distributors and major manufacturers of sanitary supplies used in the food, dairy, beverage, pharmaceutical and personal care industries.

IAFIS

The International Association of Food Industry Suppliers

VNE is a member of IAFIS, a nonprofit trade association of manufacturers and suppliers serving the global food industry. VNE adheres to the international standards promoted in its activities.

ISPE

The International Society for Pharmaceutical Engineering

VNE is a member of ISPE, a not-for-profit volunteer Society of technical professionals, who apply their practical knowledge in the regulated healthcare manufacturing industries. ISPE is committed to advancement of the education and technical efficiency of its members through forums for the exchange of ideas and practical experience.

ASME

American Society of Mechanical Engineers

VNE is a member of ASME International, a nonprofit educational and technical organization serving worldwide membership of 125,000. Established to promote technical competency through quality programs and activities in the mechanical engineering fields.

VALLEES



Butterfly Valves

BUTTERFLY VALVES

“B” SERIES BUTTERFLY VALVES

BUTTERFLY VALVES....

Butterfly Valves are available in Manual, Air Actuated, or Air Actuated with two Micro switches and a Solenoid Valve. Clamp or Weld ends are standard. Other connections are available upon request.

Available seat materials include Silicone, Viton®, and EPDM. Sizes range from 1” through 4”. All product contact surfaces are available in either T304 or T316 stainless steel.



BUTTERFLY VALVES SPECIFICATIONS....

Size Range: 1” through 4” sizes available

Materials: T304
T316

Info: All stainless handle with four position keeper is standard.

Silicone seats are standard - other seats available are EPDM and Viton®.

ORDERING SPECIFICATIONS....

- Specify:**
- Quantity
 - Product description or Part No.
 - Size
 - Material Type

VNE CORPORATION

P.O. Box 1698 • 1149 Barberry Drive • Janesville, WI 53547

TEL: 608-756-4930 • FAX: 608-756-3643 • 1-800-356-1111 • Web site: vnestainless.com

PNEUMATICALLY OPERATED

PNEUMATICALLY OPERATED BUTTERFLY VALVE INFORMATION

- Air to open, spring to close is standard.
- Unique design provides higher torque at final closing of disc.
- One actuator fits 1" through 4" valves.
- Air pressure required 58-108 psi to operate actuator.
- No spare parts required.
- Maintenance free actuator.

TECHNICAL APPLICATION DATA

- Maximum product pressure 109 psi
- Maximum product temperature 203°F
- Minimum product temperature 14°F

PNEUMATICALLY OPERATED BUTTERFLY VALVE

DIMENSIONAL CHART

Size	C	C	D	E
	All Steel Internal	Polymer Internals		
1"	7 57/64"	8 23/32	3/4"	2 61/64"
1 1/2"	8 3/64"	8 57/64	3/4"	3 3/16"
2"	8 11/32"	9 11/64	3/4"	3 21/32"
2 1/2"	8 37/64"	9 13/32	3/4"	4 3/32"
3"	8 53/64"	9 21/32	3/4"	4 17/32"
4"	9 7/16"	10 17/64	3/4"	5 43/64"

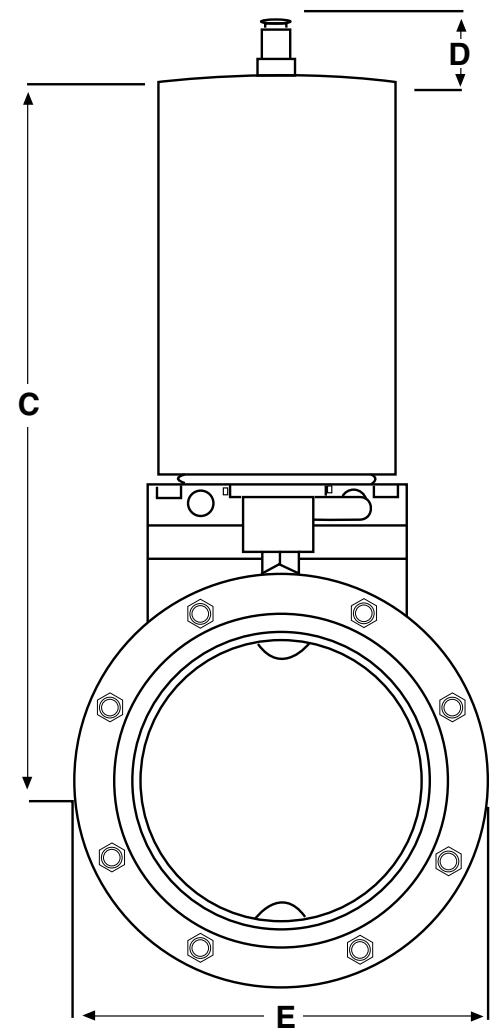

MANUAL BUTTERFLY VALVE

MANUAL BUTTERFLY VALVE INFORMATION

Note: If other Elastomer is required add suffix as follows: (E) EPDM (V) Viton®

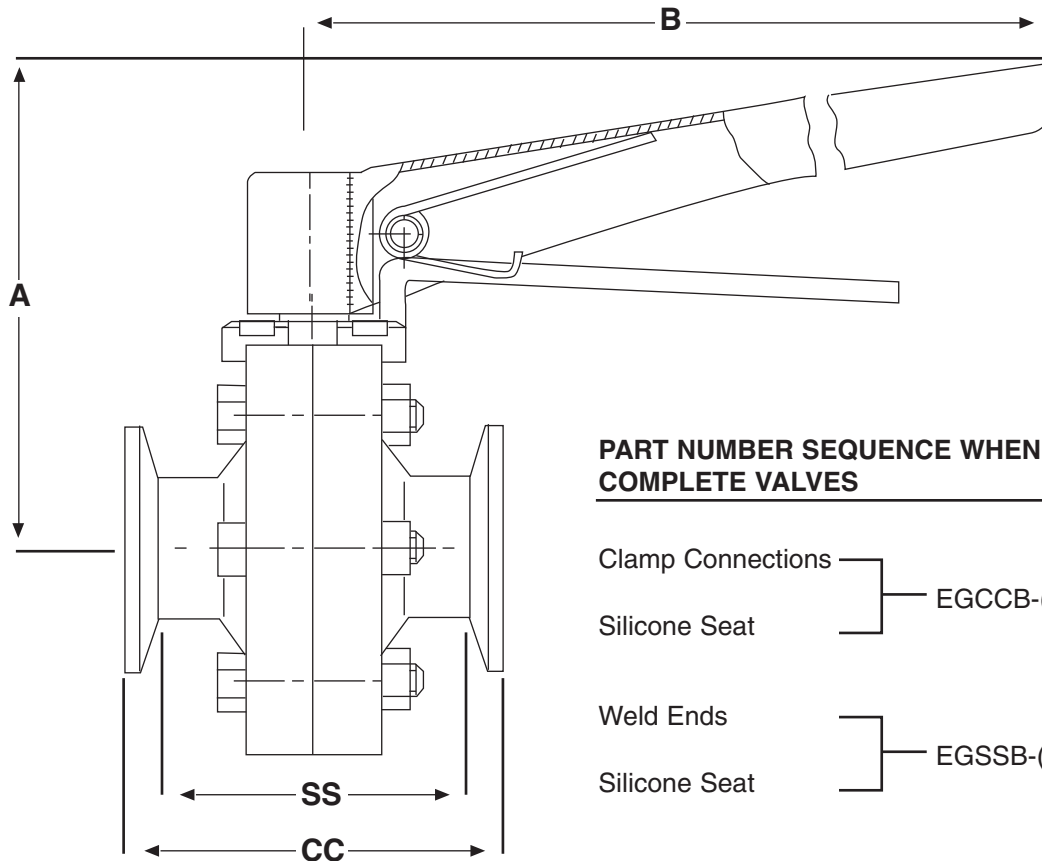

PART NUMBER SEQUENCE WHEN ORDERING COMPLETE VALVES

- Clamp Connections
 - Silicone Seat
 - Weld Ends
 - Silicone Seat
- } EGCCB-(Valve Size)
- } EGSSB-(Valve Size)

Note: To order above items in T316 add a 6 before size.
IE: EGSSB-6-SIZE

MANUAL BUTTERFLY VALVE

DIMENSIONAL CHART

Size	CC	SS	A	B	Number of Bolts
1"	2 13/16"	1 13/16"	4 19/32"	7"	4"
1 1/2"	2 13/16"	1 13/16"	4 23/32"	7"	4"
2"	2 13/16"	1 13/16"	4 15/16"	7"	6"
2 1/2"	3 3/8"	2 3/8"	5 5/32"	7"	6"
3"	3 3/4"	2 3/4"	5 3/8"	7"	6"
4"	4"	2 3/4"	5 15/16"	7"	8"

MANUAL BUTTERFLY VALVE

PARTS DRAWING & INFORMATION

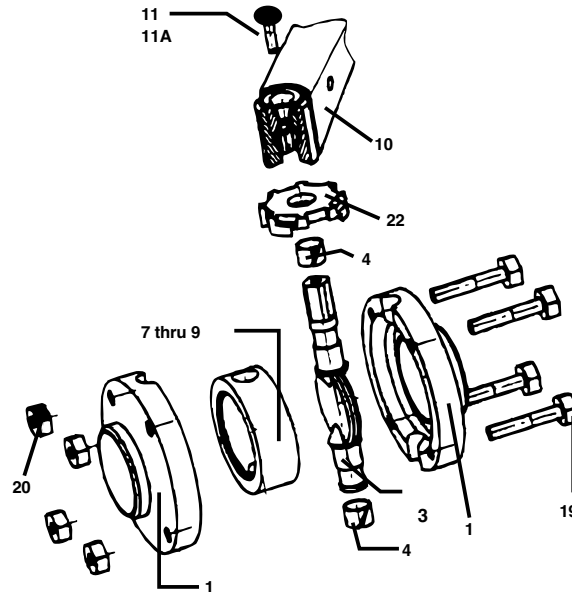

MANUAL BUTTERFLY VALVE

PARTS LIST

Item	Part Number	Description
1	*BVP-B-96-1-(size)	Body Half - Weld End
1A	*BVP-B-96-1A-(size)	Body Half - Bevel Seat Thread (not shown)
2	*BVP-B-96-2-(size)	Body Half - Clamp (not shown)
3	*BVP-B-96-3-(size)-H	Disc
4	BVP-B-96-4-(size)-H	Teflon Bushing (2 required)
7	BVP-B-76-7-(size)-H	Seat - Silicone (Standard)
8	BVP-B-96-8-(size)-H	Seat - EPDM
9	BVP-B-96-9-(size)-H	Seat - Viton®
10	BVP-B-96-10	All Stainless Handle
11	BVP-B-96-11	Thumbscrew
**11A	BVP-B-00-11A	Allen Head Handle Seat Screw
15A	BVP-B-96-15A	Mounting Bracket for Actuator on Clamp Type Valve (not shown)
15B	BVP-B-96-15B	Mounting Bracket for Actuator on Flange Type Valve (not shown)
19	BVP-B-96-19	Bolts for Body Half
19L	BVP-B-96-19L	Long Bolts for Mounting Actuator Bracket (not shown)
20	BVP-B-96-20	Nuts for Body Half
20A	BVP-B-96-20A	Wing Nuts for Body Half (not shown)
20AS	BVP-B-96-20AS	Wing Nuts for 3" Body Half Only (not shown)
22	BVP-B-96-22	Handle Seat

*To order above items in T316 stainless steel add a 6 before size. IE: BVP-B-96-1-6-SIZE

ELECTRONIC BUTTERFLY VALVE

ELECTRONICALLY-CONTROLLED PNEUMATICALLY OPERATED BUTTERFLY VALVE

- Electro-magnetic air solenoid valve provides quick positive response to control signal
- Two limit switches provide confirmation of valve position to central control panel
- Available in 110V or 24V
- All controls are protected under the splash-proof cover on top of the cylinder
- Two Indicating Lights on outside of valve for visual inspection

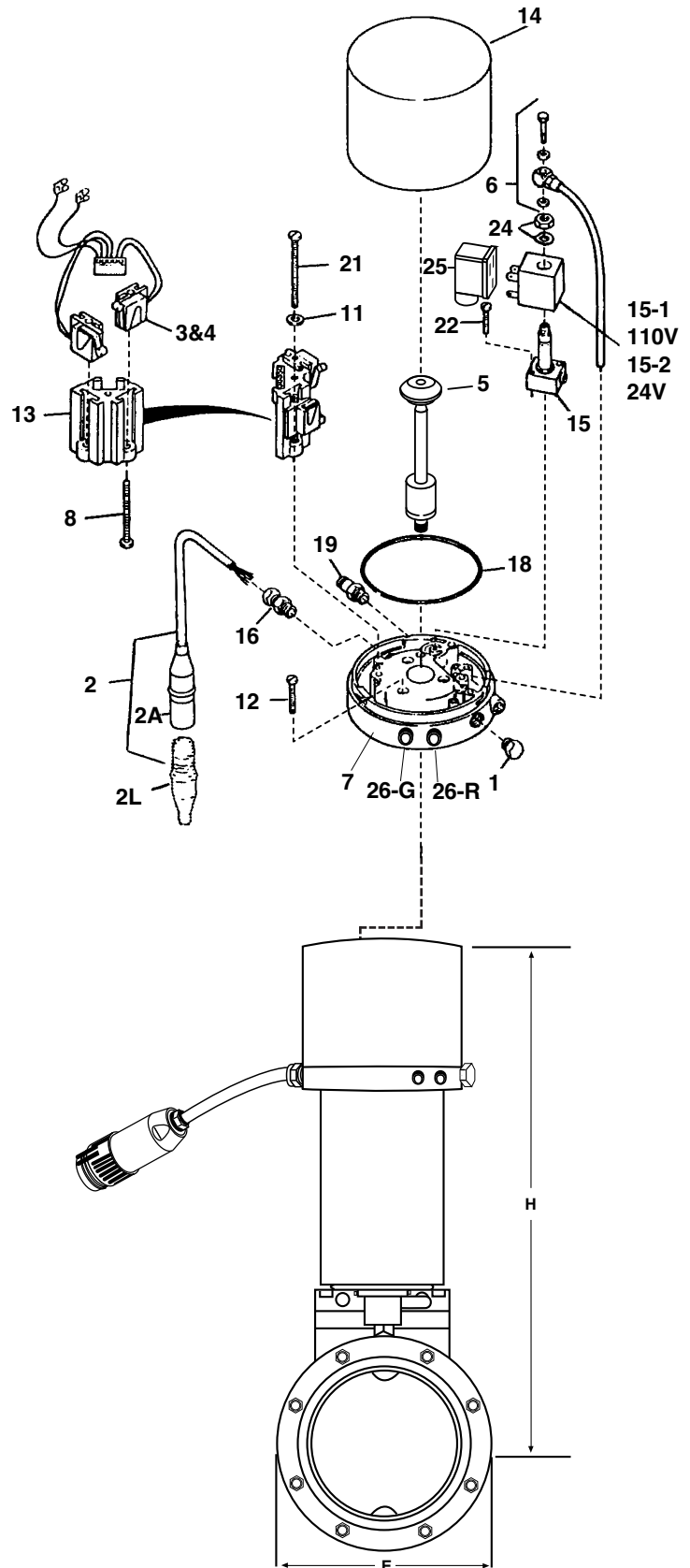

ELECTRONIC ACTUATOR

PARTS LIST

Item	Part Number	Description
1	BVP-ACTUC-1	Stainless Plugs (2)
2	BVP-ACTUC-2	Elec. Adapter (Complete)
2A	BVP-ACTUC-2A	Elec. Adapter (Actuator Side)
2L	BVP-ACTUC-2L	Elec. Adapter (Line Side)
3+4	BVP-ACTUC-3+4	Micro Switches with Harness and Terminal Strip (Complete)
5	BVP-ACTUC-5	Micro Switch Activator
6	BVP-ACTUC-6	Air Vent Tube Assembly
7	BVP-ACTUC-7	Plastic Molded Base
8	BVP-ACTUC-8	Adj. Screws for Micro Switch (2 Required)
11	BVP-ACTUC-11	Washer for Block
12	BVP-ACTUC-12	Base Screws (3 Required)
13	BVP-ACTUC-13	Switch Block
14	BVP-ACTUC-14	Cover
15	BVP-ACTUC-15	Solenoid Valve
15-1	BVP-ACTUC-15-1	110V Coil Only
15-2	BVP-ACTUC-15-2	24V Coil Only
16	BVP-ACTUC-16	Cable Adapter Fitting
18	BVP-ACTUC-18	Cover O-Ring
19	BVP-ACTUC-19	Air Inlet Fitting
21	BVP-ACTUC-21	Screw for Block
22	BVP-ACTUC-22	Screws for Solenoid (2 Required)
24	BVP-ACTUC-24	Nut and Washer for Coil-Solenoid
25	BVP-ACTUC-25	Plug Connection to Solenoid
26-G	BVP-ACTUC-26G	Indicating Light (Green)
26-R	BVP-ACTUC-26R	Indicating Light (Red)
23	BVP-B-96-23	Air Inlet Fitting (not shown)
24	BVP-B-96-24	Coupler for Clamp Type Valve, Visual Stem Indicator (not shown)
25	BVP-B-96-25	Coupler for Flange Type Valve, Visual Stem Indicator (not shown)
25A	BVP-B-96-25A	Rivet for Coupler (not shown)

ELECTRONICALLY-CONTROLLED PNEUMATICALLY OPERATED VALVE

DIMENSIONAL CHART

Size	E	H
1"	2 61/64"	11 57/64"
1 1/2"	3 3/16"	12 3/64"
2"	3 21/32"	12 11/32"
2 1/2"	4 3/32"	12 37/64"
3"	4 17/32"	12 53/64"
4"	5 43/64"	13 7/16"

PNEUMATICALLY OPERATED AND/OR ELECTRONICALLY-CONTROLLED BUTTERFLY VALVE

PART NUMBER SEQUENCE WHEN ORDERING COMPLETE VALVES

ASPCCB (Size) -	Clamp End T304 Butterfly Valve with Electronically Controlled all Stainless Air to Spring Actuator & Silicone Seat.
ASPSSB (Size) -	Weld End T304 Butterfly Valve with Electronically Controlled all Stainless Air to Spring Actuator & Silicone Seat
ASPCCB-NE (Size) -	Clamp End T304 Butterfly Valve with all Stainless Air to Spring Actuator & Silicone Seat
ASPSSB-NE (Size) -	Weld End T304 Butterfly Valve with all Stainless Air to Spring Actuator & Silicone Seat
ASPCCB-6 (Size) -	Clamp End T316L Butterfly Valve with Electronically Controlled all Stainless Air to Spring Actuator & Silicone Seat.
ASPSSB-6 (Size) -	Weld End T316L Butterfly Valve with Electronically Controlled all Stainless Air to Spring Actuator & Silicone Seat
ASPCCB-6NE (Size) -	Clamp End T316L Butterfly Valve with all Stainless Air to Spring Actuator & Silicone Seat
ASPSSB-6NE (Size) -	Weld End T316L Butterfly Valve with all Stainless Air to Spring Actuator & Silicone Seat
APPCCB-NE (Size) -	Clamp End T304 Butterfly Valve with Stainless & Polymer Internal Components Air to Spring Actuator & Silicone Seat
APPSSB-NE (Size) -	Weld End T304 Butterfly Valve with Stainless & Polymer Internal Components Air to Spring Actuator & Silicone Seat
APPCCB-6NE (Size) -	Clamp End T316L Butterfly Valve with Stainless & Polymer Internal Components Air to Spring Actuator & Silicone Seat
APPSSB-6NE (Size) -	Weld End T316L Butterfly Valve with Stainless & Polymer Internal Components Air to Spring Actuator & Silicone Seat

Note: If other Elastomer is required add suffix as follows: (E) EPDM
(V) Viton®

ACT-AS-NE-B -	All Stainless Air to Spring T304 Actuator
ACT-AP-NE-B -	Stainless & Polymer Internal Components Air to Spring T304 Actuator
ACT-AS-(110V/ 24V) -	All Stainless Electronically Controlled Air to Spring T304 Actuator. Designate 110V or 24V

VALVES



Check Valves

CHECK VALVES

BALL, SPRING AND AIR BLOW CHECK VALVES

CHECK VALVES....

Check Valves are widely used for both sanitary and industrial applications to prevent backflow of product.

Ball Check Valves are designed to allow full product flow during processing. Once the product flow stops the ball rolls back to the seat at inlet preventing back flow. Ball Check Valves are commonly used with liquid products. Sizes range 1 1/2" - 3".

Spring Check Valves are designed to assist closure pressure to create a positive shutoff. They are commonly used with liquid products. Sizes range 1/2" - 4".

Both valves are offered with standard clamp ends. Other connections are available upon request. Valves are made of T316L stainless steel.

Air Blow Check Valves are designed to evacuate lines of product or CIP solutions. Air Blow Check Valves are made of T316L Stainless Steel.



ORDERING SPECIFICATIONS....

- Specify:**
- Quantity
 - Product description or Part No.
 - Size
 - Material Type

VNE CORPORATION

P.O. Box 1698 • 1149 Barberry Drive • Janesville, WI 53547

TEL: 608-756-4930 • FAX: 608-756-3643 • 1-800-356-1111 • Web site: vnestainless.com

BALL CHECK VALVE

INFORMATION

- Precision machined seat to ensure positive shut-off
- Two-piece construction for easier alignment during installation
- Other connections available upon request
- Buna-N and Viton® elastomers
- Polished ID and OD
- All metal contact surfaces of T316L stainless steel
- Sizes range from 1 1/2" through 3"
- Meets 3A sanitary standards
- Buna Ball & Gaskets Standard



PARTS BREAKDOWN

1. Seat body - (Clamp)
- 1W. Seat body - (Weld)
2. Cap
- 3B. Ball-(Buna-N)
- 3V. Ball-(Viton®)
4. Angle body
- 4W. Angle body-(Weld)
5. Body clamp
- 6B. Body gasket-(Buna-N)
- 6V. Body gasket-(Viton®)
7. Cap clamp
- 8B. Cap gasket-(Buna-N)
- 8V. Cap gasket-(Viton®)

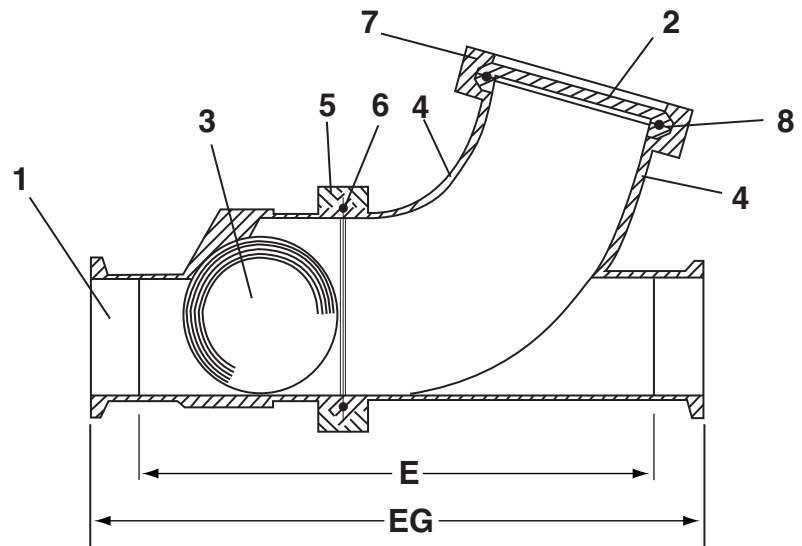

PART NUMBER SEQUENCE WHEN ORDERING COMPLETE VALVE:

- Clamp connections EG45BY-6 (valve size)
 Weld ends E45BYWW-6 (valve size)
 Note: If Viton® elastomers are required, add "V" after size

PART NUMBER SEQUENCE WHEN ORDERING REPLACEMENT PARTS:

- BCV (item number) - (valve size)
 Example: BCV3B-1.5 = Buna-N ball for 1.5 valve

Valve Size	Nominal Size				Actual Size	Overall Length		Approx. Wt. Lbs.
	1 & 4 Body	2 Cap	5 & 7 Clamp	6 & 8 Gasket	3 Ball	EG Clamp	E Weld	
1.5	1.5"	2.5"	2.5"	2.5"	2 1/8"	10	9	4.80
2.0"	2.0"	3.0"	3.0"	3.0"	2 5/8"	11	10	6.30
2.5"	2.5"	4.0"	4.0"	4.0"	3 5/16"	14 1/8	13 1/8	10.20
3.0"	3.0"	4.5"	4.5"	4.5"	4 1/4"	13 5/8	12 5/8	11.50
*3.0"	3.0"	4.0"	4.0"	4.0"	3 5/16"	13 5/8"	12 5/8"	11.50

* Redesigned February 2003. Valves purchased after 2/03 use *3.0 dimensions.

SPRING CHECK VALVE

INFORMATION

- One piece stem with O-Ring construction (easy seal replacement and positive shut-off)
- Viton O-Ring standard (other available upon request)
- Clamp connections standard (other connections available upon request)
- Full Polished ID and OD
- All metal contact surfaces of T316L Stainless Steel
- Sizes range from .5" through 4.0"
- Meets 3A sanitary standards



PARTS BREAKDOWN

1. Lower body - (Body)
2. Stem - (2.0 thru 4.0 have guide fingers)
3. Spring - standard (3-5 psi)
- 3L Spring Light - (1-3 psi) Available upon request
4. O -Ring - standard Viton
5. Stem guide
6. Upper body - (Bonnet)
7. Body Clamp .5 and" .75" = 13MHHM-H 1.5
Body Clamp 1.0" and 1.5" = 13MHHM-H 2.5
Body Clamp 2.0" = 13MHHM-H 3.0
Body Clamp 2.5" = 13MHHM-H 4.0
Body Clamp 3.0" = 13MHHM-H 5.0
Body Clamp 4.0" = 13MHHM-H 6.0
8. Clamp Gasket .5 and .75 = EG40V 1.5
Clamp Gasket 1.0 and 1.5 = EG40V 2.5
Clamp Gasket 2.0 = EG40V 3.0
Clamp Gasket 2.5 = EG40V 4.0
Clamp Gasket 3.0 = EG40V 5.0
Clamp Gasket 4.0 = EG40V 6.0

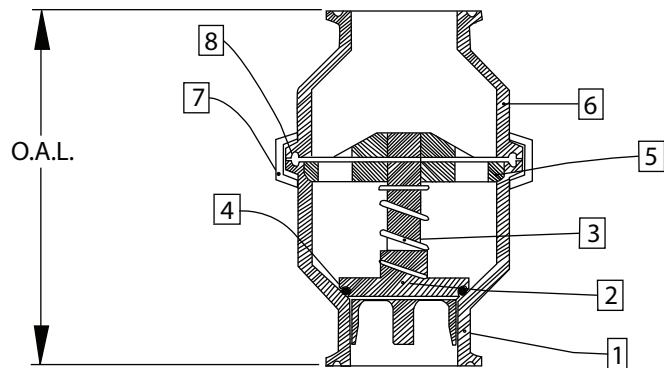

PART NUMBER SEQUENCE WHEN ORDERING COMPLETE VALVE:

45 (spring check) C (clamp) 6 (T316L) 2.0 (size) V (seat material) Example: 45C - 6 2.0 - V

When requesting O-Ring changes add the following to the end of part number

Note: V=Viton E=EDPM S=Silicone B=Buna,

PART NUMBER SEQUENCE WHEN ORDERING REPLACEMENT PARTS:

45-SCV (item number) - (valve size)

Example: 45-SCV1C-1.5 = Lower body clamp for 1.5 valve

Overall Length			
Valve Size	Standard Clamp	Weld and Other	Approx WT LBS
.5"	3 1/2	A.O.R	2.2
.75"	3 1/2	A.O.R.	2.2
1.0"	4 1/8	A.O.R	3.5
1.5"	4 9/16	A.O.R.	3.5
2.0"	5 1/16	A.O.R.	5.4
2.5"	5 3/8	A.O.R.	6
3.0"	6 1/8	A.O.R.	6.25
4.0"	8 1/8	A.O.R.	16

AIR BLOW CHECK VALVE

ILLUSTRATION

Air Blow Check Valves are made of T316L Stainless Steel and are offered with EPDM or Viton® Elastomers.

Note: EDPM Stem Standard

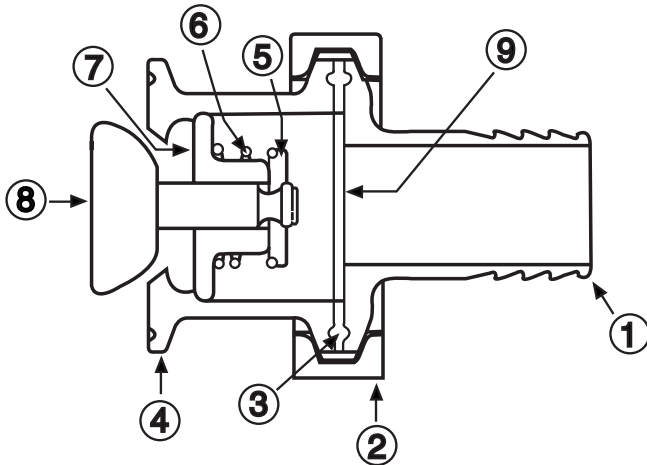

AIR BLOW CHECK VALVE CONNECTIONS

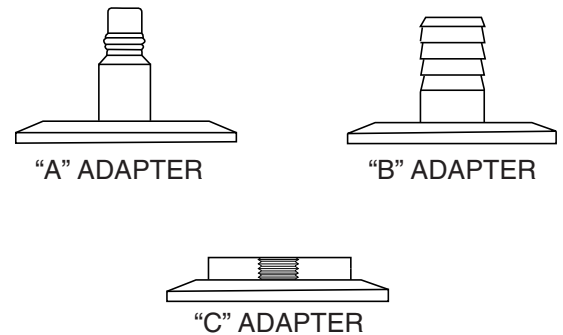

PART NUMBER SEQUENCE WHEN ORDERING COMPLETE VALVE

EG62A-6L SIZE = "A" Connection
 EG62B-6L SIZE = "B" Connection (shown)
 EG62C-6L SIZE = "C" Connection
 For Viton® Add "V" to end of part number

PARTS LIST

1. ADAPTER

- ABV1A = Air Line Quick Coupler
- ABV1B = Rubber Hose Barb 1"
- ABV1C = Thermometer Cap
 - 1. EG23B-6L 1.5 x .375 FNPT
 - 2. EG23B-6L 1.0 x .500 FNPT

2. CLAMP

- 13MHHM 1.5 = 1 1/2" All Sizes

3. PERFORATED DISC

- ABV3 1.5 = 1 1/2" EPDM
- ABV3-V 1.5 = 1 1/2" Viton®

4. VALVE BODY

- ABV4 1.5 = 1 1/2" Clamp Body
- ABV4 2.0 = 2" Clamp Body
- ABV4 2.5 = 2 1/2" Clamp Body
- ABV4 3.0 = 3" Clamp Body
- ABV4 4.0 = 4" Clamp Body
- ABV4 4.5 = 4 1/2" Clamp Body

5. SPRING RETAINER

- ABV5 = All Sizes

6. SPRING

- ABV6 = All Sizes

7. STEM GUIDE

- ABV7 = All Sizes

8. STEM

- ABV8 = EPDM Stem
- ABV8-V = Viton® Stem

9. FILTER DISC

- ABV9
- 50 / PKG.

AIR BLOW CHECK VALVE

DISPOSABLE AIR FILTER MEDIA CAPACITY TEST

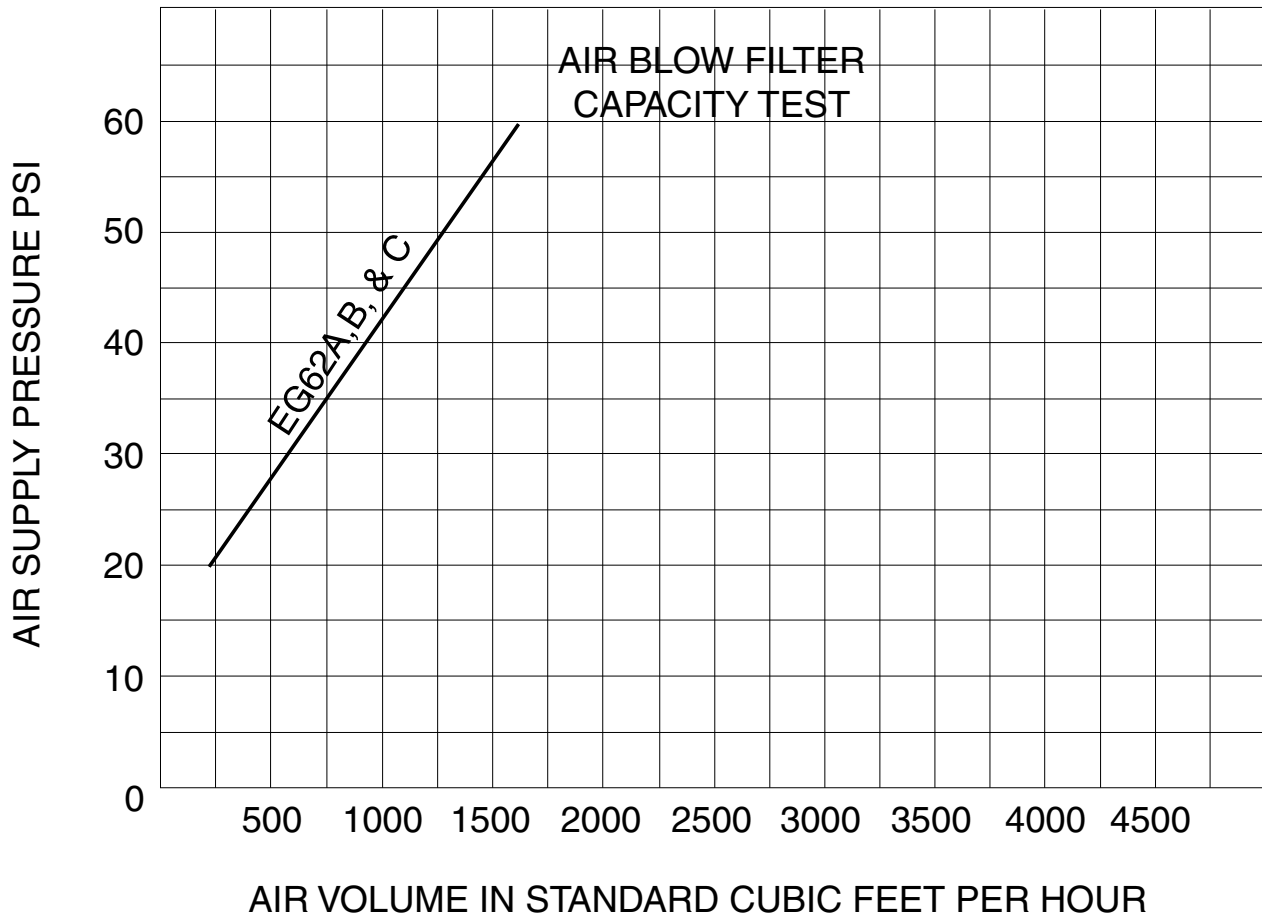

AIR BLOW CHECK VALVE

BALL CHECK WITH AIR BLOW CHECK VALVE

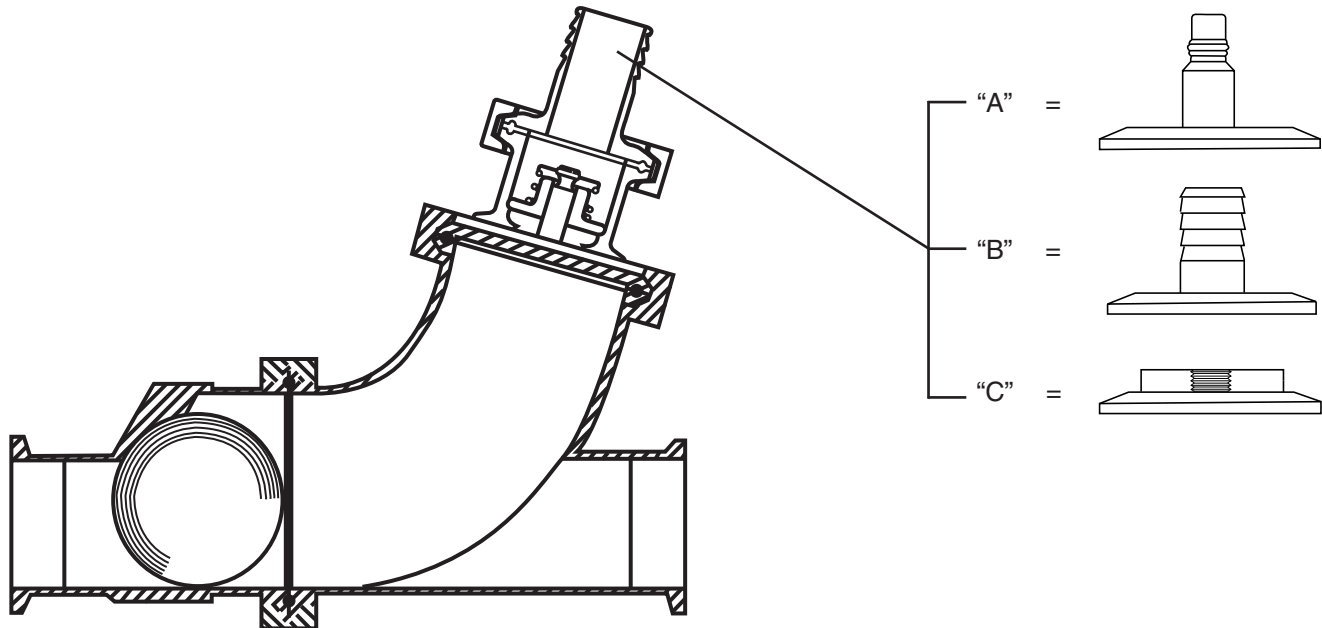

* For dimensional information see individual components

BALL CHECK WITH AIR BLOW CHECK VALVE

- Air Blow Check Valves are commonly used on ball check valves to evacuate lines of product or CIP solutions
- Easy assembly and disassembly of Air Blow Check Valve
- Buna Ball Check Valve offered standard with EPDM Air Blow Check Valve with Viton® options

PART NUMBERS FOR BALL CHECK WITH AIR BLOW CHECK VALVE

CLAMP	EG45ABA-6 SIZE = "A" Connection	WELD	E45WWABA-6 SIZE = "A" Connection
	EG45ABB-6 SIZE = "B" Connection		E45WWABB-6 SIZE = "B" Connection
	EG45ABC-6 SIZE = "C" Connection		E45WWABC-6 SIZE = "C" Connection

*For Viton® Ball, Stem, and Elastomers Add "V" to end of part number

FOR USE ON BALL CHECK VALVES:

1 1/2" Ball Check Valve uses 2 1/2" Air Blow Valve
2" Ball Check Valve uses 3" Air Blow Valve

2 1/2" Ball Check Valve uses 4" Air Blow Valve
3" Ball Check Valve uses 4" Air Blow Valve

VALVES



Ball Valves

BALL VALVES....

Ball Valves are used in a wide variety of high pressure applications. Two factors make them popular. First, a full unrestricted flow that allows no product restrictions through the valve. Second, the three piece design and the removal of a minimal number of bolts allows service to be performed without removing the complete valve from the line.

VNE offers two way ball valves made of T316 (CF8M) stainless steel. PTFE seats are easily removed. Clamp and Weld ends are standard. Other connections are available upon request. 1/2" through 4" sizes are available. Ball Valves meet FDA and 3A requirements.

VNE offers many options on automated ball valves.

BALL VALVE SPECIFICATIONS....

Size:	1/2", 3/4", 1", 1 1/2", 2", 2 1/2", 3", 4"
Material:	Passivated 316 Stainless Steel (ASTM A351, CF8M)
Connections:	Clamp & Weld - other connections available upon request
Working Pressure:	1/2" - 1" 1,000 psi 1 1/2" - 2" 1,000 psi 2 1/2" - 4" 600 psi
Temperature Rating:	-65 to 320 Degrees F

ORDERING SPECIFICATIONS....

- Specify:**
- Quantity
 - Product description or Part No.
 - Size
 - Material Type



IMPORTANT FEATURES...

- 3 - Piece design - allows valve ends to remain attached while servicing valve body
- Meets 3A and FDA requirements
- 100% Tested
- Valves marked with heat numbers for full identification and traceability
- English hardware
- Maintenance and servicing is made easy with removal of a minimal number of bolts
- Reinforced Teflon® Seats
- PTFE Cavity Filler, fully encapsulated
- Locking device handle
- Air Actuator mounting kits which include ISO-5211 pads are available
- Repair kits are available

Teflon is a trademark

VNE CORPORATION

P.O. Box 1698 • 1149 Barberry Drive • Janesville, WI 53547

TEL: 608-756-4930 • FAX: 608-756-3643 • 1-800-356-1111 • Web site: vnestainless.com

CLAMP AND WELD VALVES

PART NUMBER EG90CC-6-SIZE = CLAMP
E90WW-6-SIZE = WELD

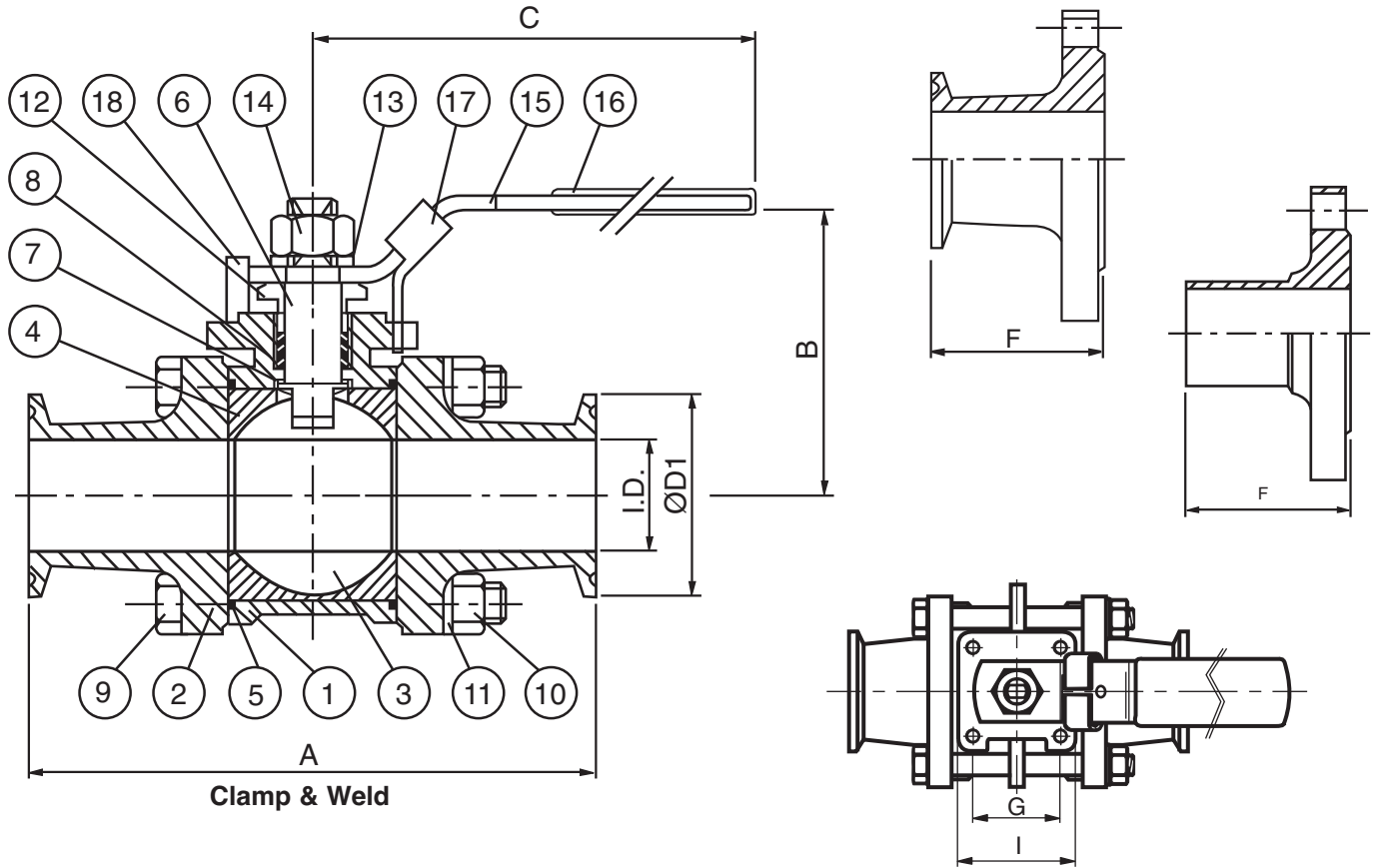

CLAMP & WELD DIMENSIONS

SIZE INCH	ISO- 5211	A	B	C	I.D.	ØD	ØD1	E	F	G	H	I
1/2"	F03	3.503	2.165	5.11	0.375	0.50	1.00	0.708	1.289	1.00	0.196	1.456
3/4"	F03	3.976	2.362	5.11	0.625	0.75	1.00	0.728	1.437	1.00	0.196	1.456
1"	F04	4.488	2.716	6.49	0.875	1.00	1.98	0.885	1.574	1.17	0.256	1.653
1 1/2"	F05	5.511	3.307	7.67	1.375	1.50	1.98	1.165	1.712	1.39	0.334	1.968
2"	F05	6.141	3.622	7.67	1.875	2.00	2.51	1.165	1.801	1.39	0.334	1.968
2 1/2"	F07	7.756	5.000	9.92	2.375	2.50	3.05	1.750	2.204	1.95	0.472	2.834
3"	F07	9.015	5.354	9.92	2.875	3.00	3.58	1.750	2.540	1.95	0.472	2.834
4"	F10	9.567	6.260	13.07	3.834	4.00	4.68	1.921	2.385	2.83	0.630	3.740

CLAMP AND WELD VALVES

PART LIST FOR CLAMP & WELD VALVES

Part Number	Description	Material	Qty.
Ball-1	Body	ASTM-A351-CF8M	1
Ball-2C	Clamp End Connection	ASTM-A351-CF8M	2
Ball-2W	Weld End Connection	ASTM-A351-CF8M	2
Ball-3	Ball	A351-CF8M	1
Ball-4	Seat	PTFE	2
Ball-5	Gasket	PTFE	2
Ball-6	Stem	AISI-316	1
Ball-7	Thrust Washer	PTFE	1
Ball-8	Stem Packing	PTFE	1
Ball-9	Bolt	AISI-304	4
Ball-10	Hex Nut	AISI-304	4
Ball-11	Bolt Washer	AISI-304	4
Ball-12	Gland	AISI-304	1
Ball-13	Washer	AISI-304	1
Ball-14	Nut	AISI-304	1
Ball-15	Handle	AISI-304	1
Ball-16	Plastic Cover	Plastic	1
Ball-17	Lock Device	AISI-304	1
Ball-18	Stop Pin	AISI-304	1

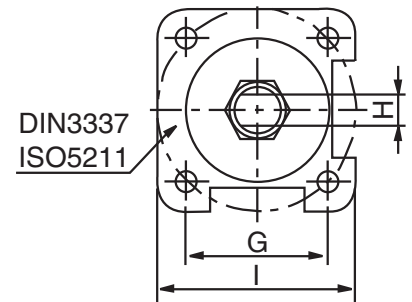
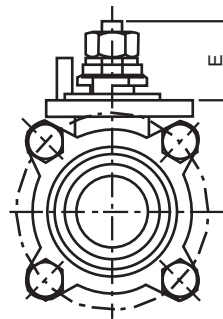
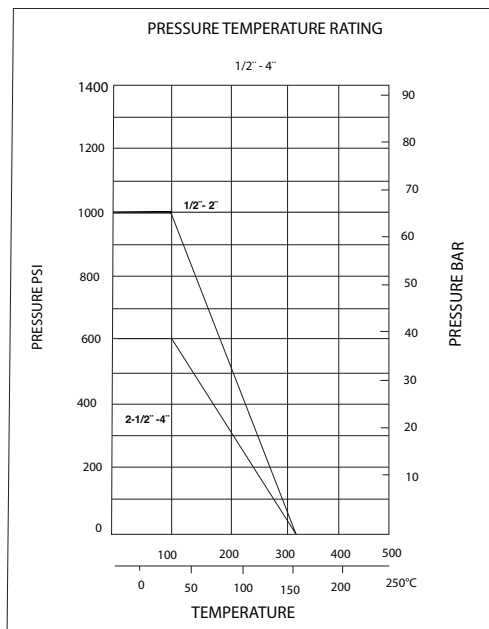

BALL VALVE TORQUE....

3-PC Type full port stainless steel 316 sanitary ball valve ferrule-end and weld-end.

1/2"	- Breakaway Torque ----	42	In-LBS
3/4"	- Breakaway Torque ----	58	In-LBS
1"	- Breakaway Torque ----	83	In-LBS
1 1/2"	- Breakaway Torque ----	150	In-LBS
2"	- Breakaway Torque ----	298	In-LBS
2 1/2"	- Breakaway Torque ----	512	In-LBS
3"	- Breakaway Torque ----	685	In-LBS
4"	- Breakaway Torque ----	996	In-LBS

Part List for Clamp and Weld Valves

Item Number	Part Number	Description	Material	Qty.
1	Ball - 3 - 1 - Size	Body	A351-CF8M	1
2	Ball - 3 - 2C - Size	Clamp Body Half	A351-CF8M	3
2	Ball - 3 - 2W - Size	Weld Body Half	A351-CF8M	3
3	Ball - 3 - 3 - Size	Ball	A351-CF8M	1
* 4	Ball - 3 - 4L - Size	Seat Large	PTFE	2
* 4	Ball - 3 - 4S - Size	Seat Small	PTFE	1
* 4	Ball - 3 - 4B - Size	Seat Back	PTFE	1
* 5	Ball - 3 - 5 - Size	Gasket	PTFE	1
* 6	Ball - 3 - 6 - Size	Thrust Washer	PTFE	2
* 7	Ball - 3 - 7 - Size	O -Ring	Viton	1
* 8	Ball - 3 - 8 - Size	Stem Packing	PTFE	1
9	Ball - 3 - 9 - Size	Ring	AISI-316	1
10	Ball - 3 - 10 - Size	Bevel Washer	AISI-301	3
11	Ball - 3 - 11 - Size	Stop Pin	AISI-316	1
12	Ball - 3 - 12 - Size	Nut	AISI- 304	2
13	Ball - 3 - 13 - Size	Stem	AISI-316	1
14	Ball - 3 - 14 - Size	Handle	AISI-304	1
15	Ball - 3 - 15 - Size	Washer	AISI-304	16
16	Ball - 3 - 16 - Size	Bolt	AISI-304	16
17	Ball - 3 - 17 - Size	Prevailing Device	AISI-304	1
18	Ball - 3 - 18 - Size	Nut Handle	AISI-304	1
19	Ball - 3 - 19 - Size	Body Cap	A351-CF8M	1
*Kit	Ball - 3 - Kit - Size	Replacement Seal kit	PTFE / Viton	1

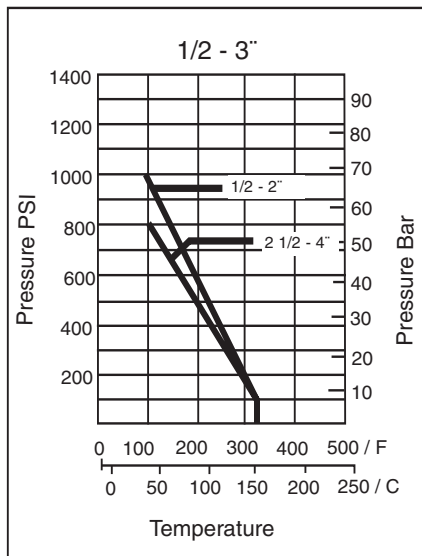

BALL VALVE TORQUE...

3-Way full port stainless steel 316 sanitary ball valve clamp and weld end. To convert In / LBS to Foot LBS X .083.

1/2"	- Breakaway Torque ---	79	In-LBS
3/4"	- Breakaway Torque ---	85	In-LBS
1"	- Breakaway Torque ---	110	In-LBS
1 1/2"	- Breakaway Torque ---	290	In-LBS
2"	- Breakaway Torque ---	680	In-LBS
2 1/2"	- Breakaway Torque ---	1287	In-LBS
3"	- Breakaway Torque ---	1770	In-LBS
4"	- Breakaway Torque ---	2035	In-LBS

Clamp Valves

Part Number EG93CCC - 6 - Size = Clamp

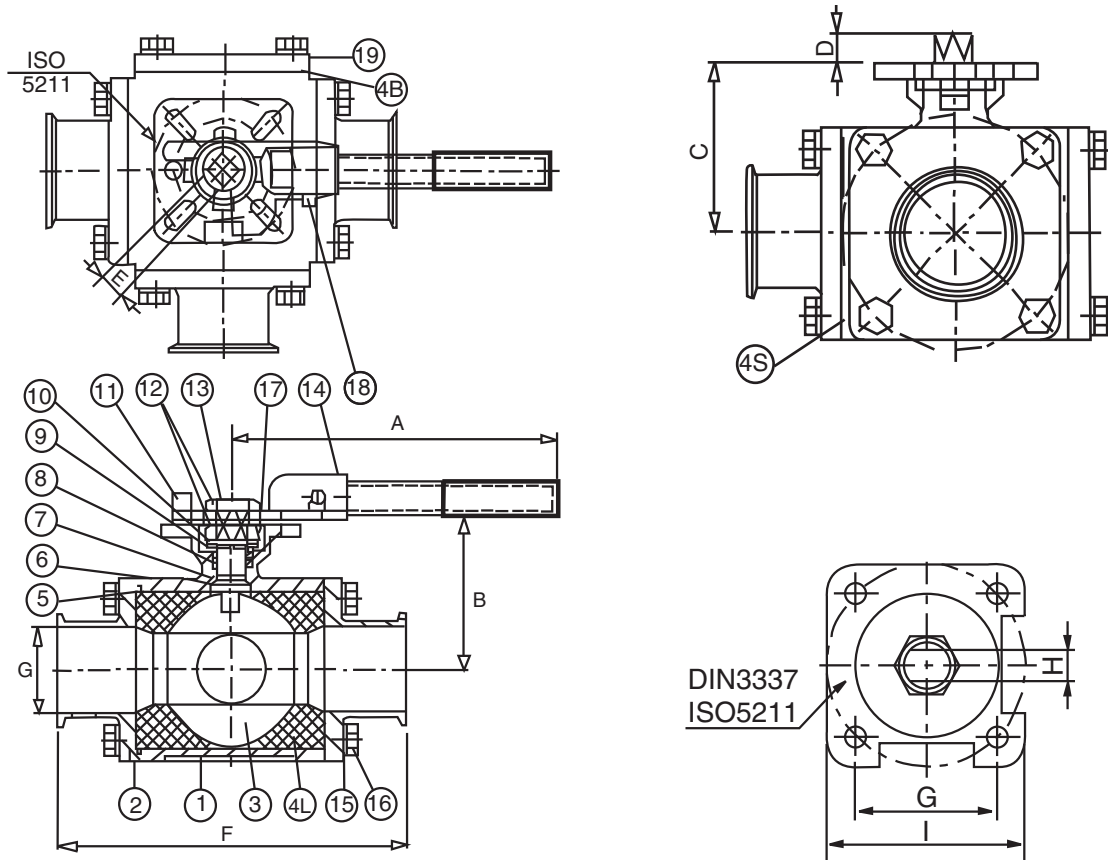

CLAMP DIMENSIONS

Size	ISO-	A	B	C	D	E	F	G	H	I	J
Inch	5211										
1/2"	F03/F04	4.75	3.0625	1.75	.375	.375	4.625	.375	.375	1.456	1.00
3/4"	F03/F04	4.75	3.25	1.875	.375	.375	5.000	.625	.375	1.456	1.00
1"	F04/F05	5.375	3.55	2.323	.5625	.433	6.000	.875	.433	1.653	1.17
1 1/2"	F05/F07	7.125	4.3125	2.8125	.5625	.5625	6.875	1.375	.5625	1.968	1.39
2"	F05/F07	7.125	4.50	3.25	.5625	.5625	7.500	1.895	.5625	1.968	1.39
2 1/2"	F07/F10	14.5625	4.25	3.9375	.6875	.6875	9.000	2.375	.6875	2.834	1.95
3"	F10/F12	15.75	5.25	5.00	.875	.875	10.250	2.875	.875	2.834	1.95

3 - WAY BALL VALVES

Weld Valves

Part Number E93WWW - 6 - Size = Weld

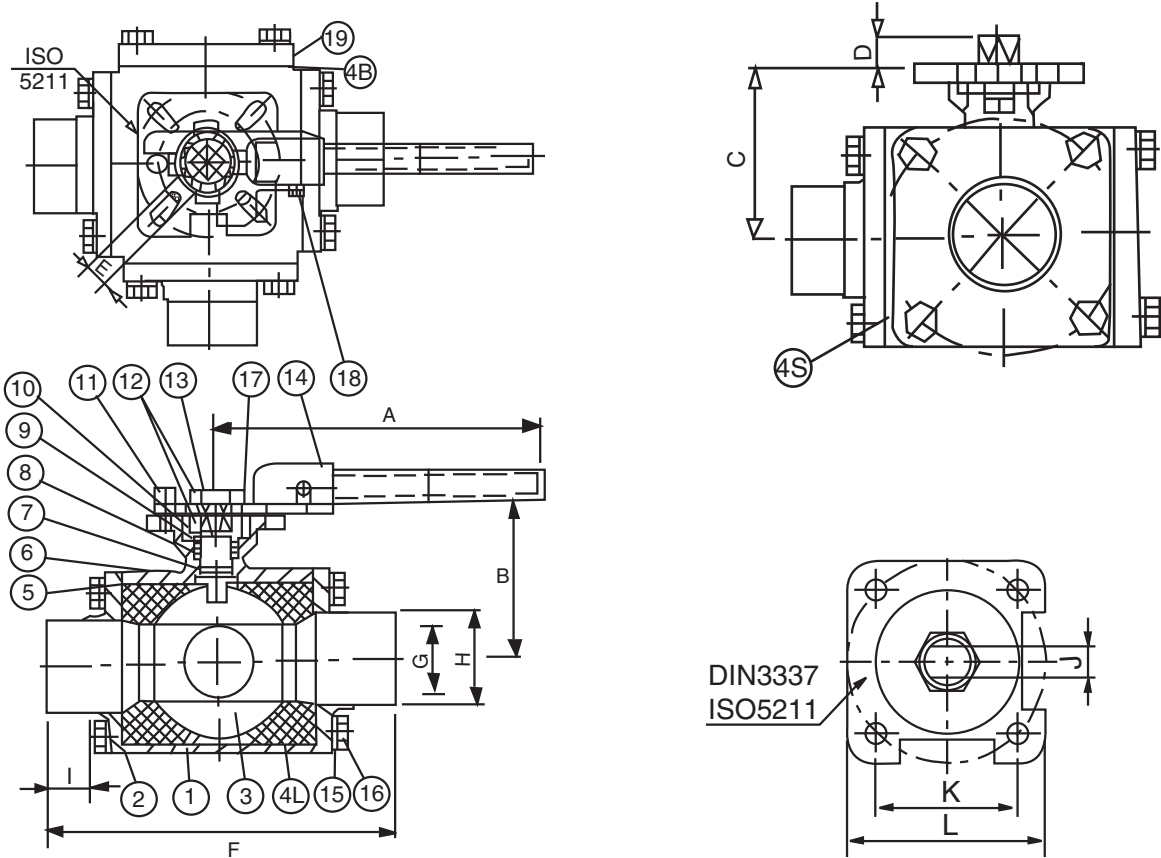

WELD DIMENSIONS

Size	ISO	A	B	C	D	E	F	G	H	I	J	K	L
Inch	5211												
1/2"	F03/F04	4.75	3.0625	1.75	.375	.375	4.625	.375	.50	.75	.375	1.00	1.456
3/4"	F03/F04	4.75	3.25	1.875	.375	.375	5.000	.625	.75	.75	.375	1.00	1.456
1"	F04/F05	5.375	3.55	2.3125	.4375	.4375	6.000	.875	1.00	1.00	.4375	1.17	1.653
1 1/2"	F05/F07	7.125	4.3125	2.8125	.5625	.5625	6.875	1.375	1.50	1.00	.5625	1.39	1.968
2"	F05/F07	7.125	4.50	3.25	.5625	.5625	7.500	1.875	2.00	1.00	.5625	1.39	1.968
2 1/2"	F07/F10	14.5625	4.25	3.9375	.6875	.6875	9.000	2.375	2.00	1.00	.6875	1.95	2.834
3"	F10/F12	15.75	5.25	5.00	.875	.875	10.25	2.875	3.00	1.00	.875	1.95	2.834

Part List for Clamp and Weld Valves

Item Number	Part Number	Description	Material	Qty.
1	Ball - 3 - 1 - Size	Body	A351-CF8M	1
2	Ball - 3 - 2C - Size	Clamp Body Half	A351-CF8M	3
2	Ball - 3 - 2W - Size	Weld Body Half	A351-CF8M	3
3	Ball - 3 - 3 - Size	Ball	A351-CF8M	1
* 4	Ball - 3 - 4L - Size	Seat Large	PTFE	2
* 4	Ball - 3 - 4S - Size	Seat Small	PTFE	1
* 4	Ball - 3 - 4B - Size	Seat Back	PTFE	1
* 5	Ball - 3 - 5 - Size	Gasket	PTFE	1
6	Ball - 3 - 6 - Size	Thrust Washer	PTFE	1
* 7	Ball - 3 - 7 - Size	O -Ring	Viton	1
* 8	Ball - 3 - 8 - Size	Stem Packing	PTFE	1
9	Ball - 3 - 9 - Size	Ring	AISI-316	1
10	Ball - 3 - 10 - Size	Bevel Washer	AISI-301	3
11	Ball - 3 - 11 - Size	Stop Pin	AISI-316	1
12	Ball - 3 - 12 - Size	Nut	AISI- 304	2
13	Ball - 3 - 13 - Size	Stem	AISI-316	1
14	Ball - 3 - 14 - Size	Handle	AISI-304	1
15	Ball - 3 - 15 - Size	Washer	AISI-304	16
16	Ball - 3 - 16 - Size	Bolt	AISI-304	16
17	Ball - 3 - 17 - Size	Prevailing Device	AISI-304	1
18	Ball - 3 - 18 - Size	Nut Handle	AISI-304	1
19	Ball - 3 - 19 - Size	Body Cap	A351-CF8M	1
*Kit	Ball - 3 - Kit - Size	Replacement Seal kit	PTFE / Viton	1

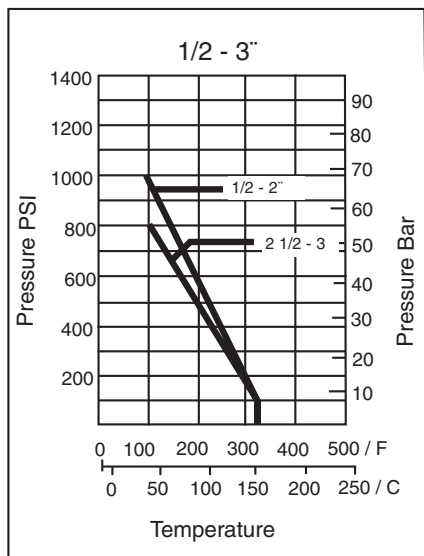

BALL VALVE TORQUE...

3-Way full port stainless steel 316 sanitary ball valve clamp and weld end. To convert In / LBS to Foot LBS X .083.

1/2"	- Breakaway Torque ---	79	In-LBS
3/4"	- Breakaway Torque ---	85	In-LBS
1"	- Breakaway Torque ---	110	In-LBS
1 1/2"	- Breakaway Torque ---	290	In-LBS
2"	- Breakaway Torque ---	680	In-LBS
2 1/2"	- Breakaway Torque ---	1287	In-LBS
3"	- Breakaway Torque ---	1770	In-LBS

Dimensions 2-way Spring Return Actuated Valve

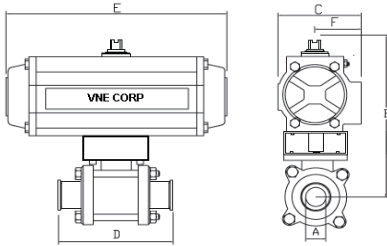

Valve Size	A	B	C	D	E	F	Weight	Cv Value
1/2	0.38	6.15	2.70	3.50	5.49	1.61	4.16	9
3/4	0.63	6.33	2.790	3.98	5.49	1.61	4.46	26
1	0.88	6.87	3.170	4.49	6.38	1.77	6.75	61
1 1/2	1.38	8.05	3.720	5.51	8.15	2.07	12.70	193
2	1.88	8.89	4.850	6.14	10.69	2.68	22.80	432
2 1/2	2.38	12.15	5.390	7.76	12.91	2.87	41.88	728
3	2.88	12.96	5.830	9.02	14.41	3.15	51.40	1125
4	3.83	15.52	7.360	9.57	20.55	3.94	111.20	1986

Dimensions 2-way Air to Air Actuated Valve

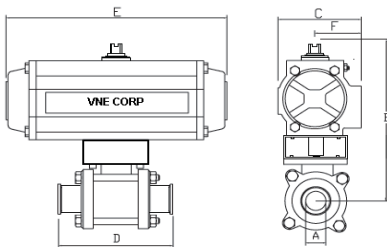

Valve Size	A	B	C	D	E	F	Weight	Cv Value
1/2	0.38	5.18	1.770	3.50	4.65	0.89	2.62	9
3/4	0.63	5.36	1.770	3.98	4.65	0.89	2.92	26
1	0.88	6.44	2.790	4.49	5.49	1.61	5.03	61
1 1/2	1.38	7.40	3.170	5.51	6.38	1.77	9.02	193
2	1.88	7.28	3.170	6.14	6.38	1.77	11.66	432
2 1/2	2.38	10.40	3.720	7.76	8.15	2.07	23.47	728
3	2.88	11.19	4.170	9.02	9.35	2.30	32.03	1125
4	3.83	13.30	5.390	9.57	12.91	2.87	63.91	1986

Dimensions 3-way Spring Return Actuated Valve

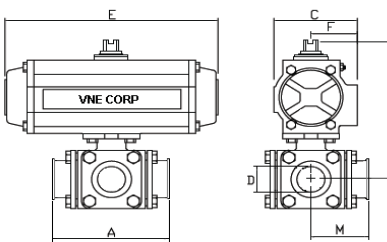

Valve Size	A	B	C	D	E	F	M	Weight	Cv Value
1/2	4.65	5.28	2.790	0.38	5.49	1.61	2.33	6.62	L-8-T-6
3/4	5.00	5.40	2.790	0.63	5.49	1.61	2.50	7.62	L-17 T-13
1	6.00	6.28	3.170	0.88	6.38	1.77	3.00	10.97	L-25 T-19
1 1/2	6.88	8.38	4.850	1.38	10.69	2.68	3.44	28.40	L-62 T-46
2	7.88	9.61	5.390	1.88	12.91	2.87	3.94	47.92	L-148 T-92
2 1/2	9.72	11.65	6.450	2.38	16.85	3.44	4.86	73.28	L-247 T-156
3	11.30	13.58	7.360	2.88	20.55	3.94	5.65	110.04	L-351 T-230

Dimensions 3-way Spring Return Actuated Valve

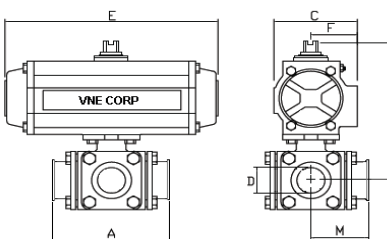

Valve Size	A	B	C	D	E	F	M	Weight	Cv Value
1/2	4.65	5.28	2.790	0.38	5.49	1.61	2.33	6.25	L-8 T-6
3/4	5.00	5.40	2.790	0.63	5.49	1.61	2.50	7.25	L-17 T-13
1	6.00	5.85	2.790	0.88	5.49	1.61	3.00	9.25	L-25 T-19
1 1/2	6.88	6.77	3.170	1.38	6.38	1.77	3.44	17.26	L-62 T-46
2	7.88	8.31	4.170	1.88	9.35	2.30	3.94	21.39	L-148 T-92
2 1/2	9.72	9.51	4.850	2.38	10.69	2.68	4.86	56.28	L-247 T-156
3	11.30	11.36	5.390	2.88	12.91	2.87	5.65	62.75	L-351 T 230

3-WAY BALL VALVE CONFIGURATION OPTIONS Standard Actuator (CW to Close, CCW to Open)

T-Port Design

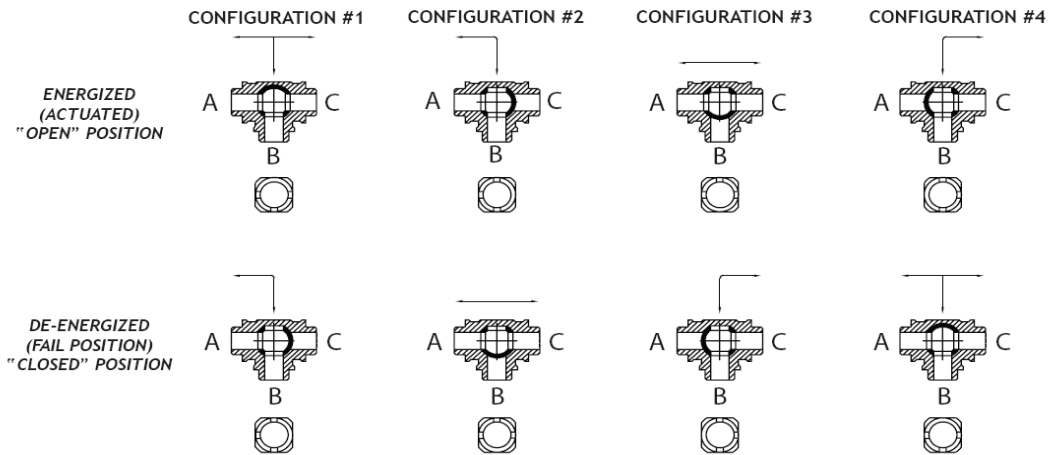

L-Port Design

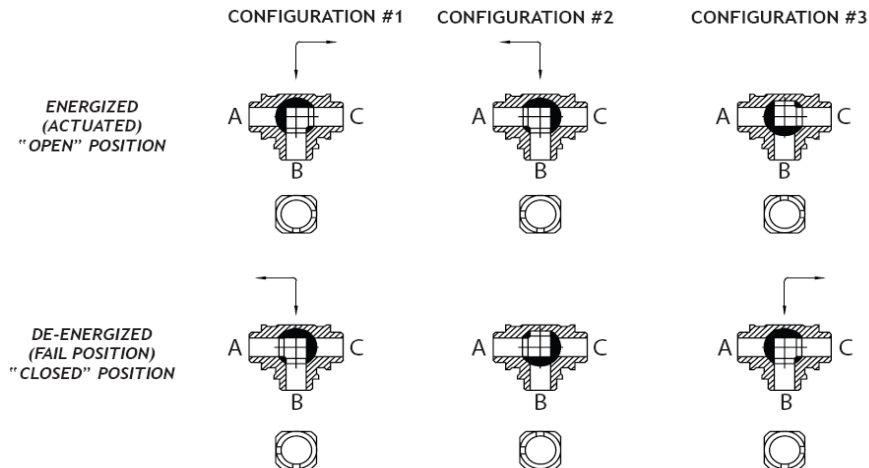

3-WAY BALL VALVE CONFIGURATION OPTIONS

Reverse - Acting Actuator (CCW to Close, CW to Open)

T-Port Design

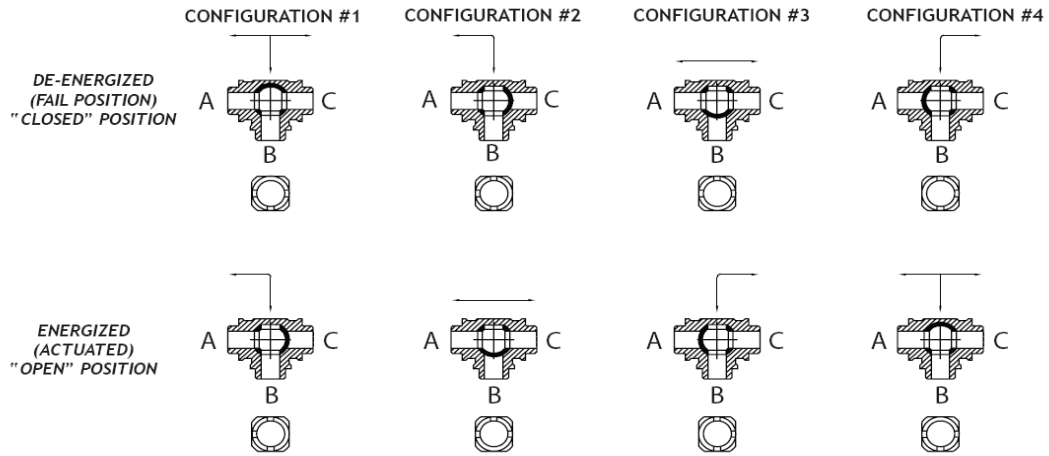

L-Port Design

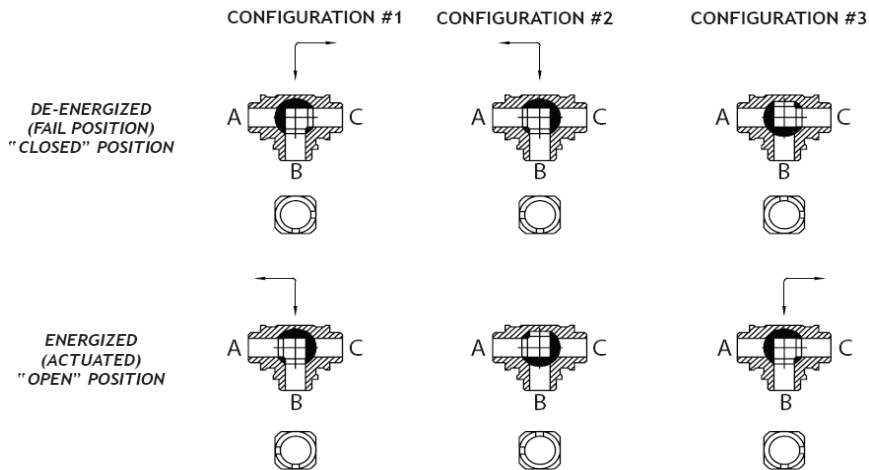

ACTUATED BALL VALVE PART NUMBERING

Example: 93C1.0C(actuator size)D2

1.0 Clamp End 3-Way Ball Valve L Port Configuration 2 with Double Acting Actuator

Valve Body		Size	Finish		Actuator	Action	Fail Position / Flow Pattern	Accessory 1 (Solenoid)	Accessory 2 (Limit Switch)
90C	Clamp 2-Way	.5	C	Standard	* Contact VNE for Proper Actuator Sizing	S Spring Return	O 2-Way Fail Open	X Omitted	X Omitted
90W	Weld 2-Way	.75		20 Ra ID		D Double Acting	C 2-Way Fail Closed (Standard)	A 120VAC Nema 4	A 2SPDT Mech. Limit Switches / Dome Ind. Nema 4
93C	Clamp 3-Way L Port	1.0	D	15 Ra EP ID		E Fully Electric	1 3-Way Configuration 1 (Standard)	B 24VDC Nema 4	B 2 Inductive Prox. Switches / Dome Ind. Nema 4
93W	Weld 3-Way L Port	2.0				P Stainless Steel Spring Return	2 3-Way Configuration 2		
		2.5				Q Stainless Steel Double Acting	3 3-Way Configuration 3		
93CT	Clamp 3-Way T Port	3.0					4 3-Way Configuration 4		
		4.0					R1 Reverse-Acting 3-Way Configuration 1		
93WT	Weld 3-Way T Port						R2 Reverse-Acting 3-Way Configuration 2		
90AW	Orbital Weld 2-Way						R3 Reverse-Acting 3-Way Configuration 3		
93AW	Orbital Weld 3-Way						R4 Reverse-Acting 3-Way Configuration 4		

*Conditions such as pressure, temperature, type of media, amount and kind of suspended material in the media, and frequency of operation all affect proper actuator sizing.

VALVES



PVA Valves

PVA VALVE

VNE'S MODULAR DESIGN SANITARY PROCESS VALVE

PVA VALVE....

This valve has an all stainless one piece stem which seals against the body O-ring for positive shut off. With this design, no seals, disks, or O-rings are fastened to the stem, which could cause product entrapment.

MODULAR DESIGN....

A modular design is used throughout this entire line of valves.

SANITARY....

PVA valves meet 3A requirements. With this state of the art design, it allows optimum CIP cleaning of all product contact surfaces.

PVA VALVE....

- Available in 1" - 3"
- Made from T316L Stainless Steel
- Offered as EPDM Standard with Viton® and Silicone options.
- Available in Shut off, Divert, and Tank Outlet Configurations.
- Available with Clamp, Weld, Bevel Seat, and E-Line connections. Other connections are available upon request.
- Available in manual or air actuated. An electronic control head can be used with these air operated valves.

PVA ACCESSORIES....

- Micro switches with Solenoid Valve 110 or 24 volt.
- Indicating lights for open and closed position.
- Tank Bottom Adapter - For Tank Outlet Valve



PVA ACTUATOR....

- Maintenance free
- Instantly reversible from normally open (NO) to normally closed (NC) or vice versa.
- Instant assembly of electronic control head.
- Two size Actuators: 4" diameter for 1 1/2" and 2" valves. 5" size for 2 1/2" and 3" valves. Made from T304 Stainless Steel.
- Position indicator stem on top of actuator shows open or closed position.
- Operating Air Pressure range 72 - 108 PSI.



VNE CORPORATION

P.O. Box 1698 • 1149 Barberry Drive • Janesville, WI 53547

TEL: 608-756-4930 • FAX: 608-756-3643 • 1-800-356-1111 • Web site: vnestainless.com

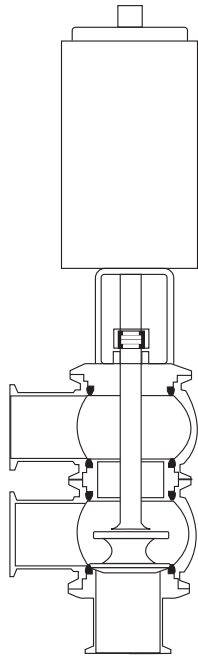

EGPVA-77-NC (NO)-SIZE

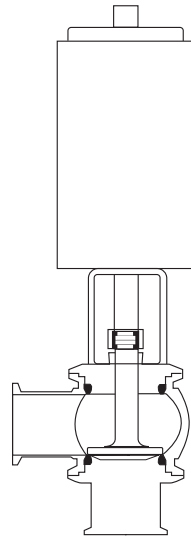

EGPVA-7-NC (NO)-SIZE

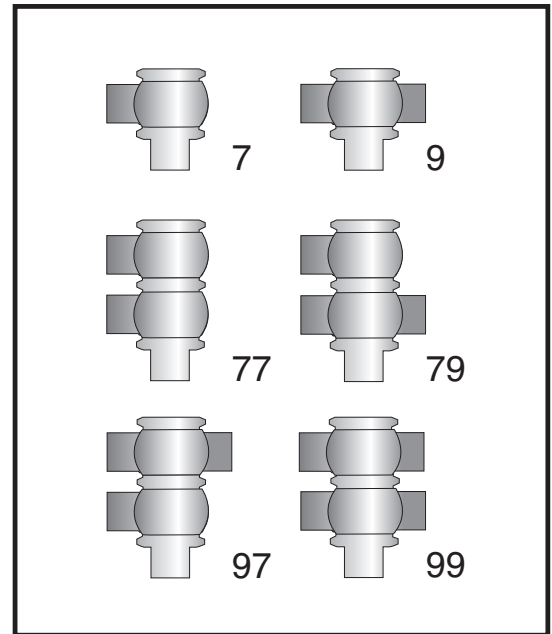

CONFIGURATIONS

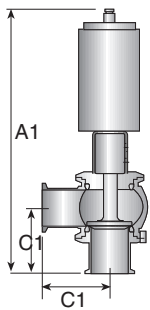

SHUT-OFF-VALVE
CLAMP & WELD

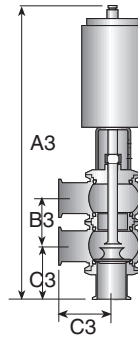
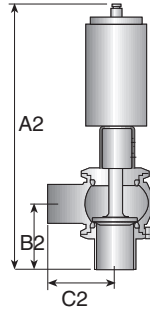

DIVERT-VALVE
CLAMP & WELD

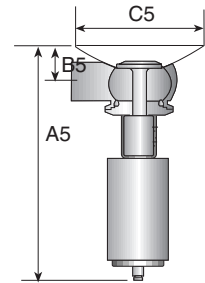
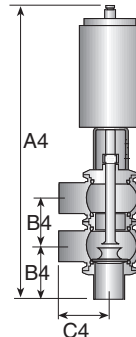

TANK-BOTTOM VALVE
WELD

DIMENSION TABLE

SIZE	A1	A2	A3	A4	A5	B2	B3	B4
1 1/2"	15 7/16	14 15/16	18 1/4	17 11/16	15 29/32	2 1/4	2 3/4	2 3/4
2"	16 5/16	15 7/8	19 1/2	19	16 5/16	3	3 1/8	3 1/8
2 1/2"	17 9/16	17	21 1/2	21	17 1/2	3	3 15/16	3 15/16
3"	19	18 1/2	23	22 7/16	18 1/2	3 1/4	4 3/4	4 3/4
SIZE	b4	B5	C1	C2	C3	C4	C5	--
1 1/2"	2 3/8	2 3/8	2 3/4	2 3/4	2 3/4	2 3/4	5 7/8	--
2"	3	2 9/16	3 1/2	3 1/2	3 1/2	3 1/2	5 7/8	--
2 1/2"	3	3 7/32	3 1/2	3 1/2	3 1/2	3 1/2	7 3/32	--
3"	3 1/4	3 13/16	3 3/4	3 3/4	3 3/4	3 3/4	7 7/8	--

SHUT OFF VALVE

EGPVA-7-NC(NO)-SIZE

*If control head is required add
110V or 24V to part number.

*For Manual operation

Part Number:
EGPVA-7-MAN-SIZE = Shut-Off

*For Viton® add - V

*For Silicone add - S

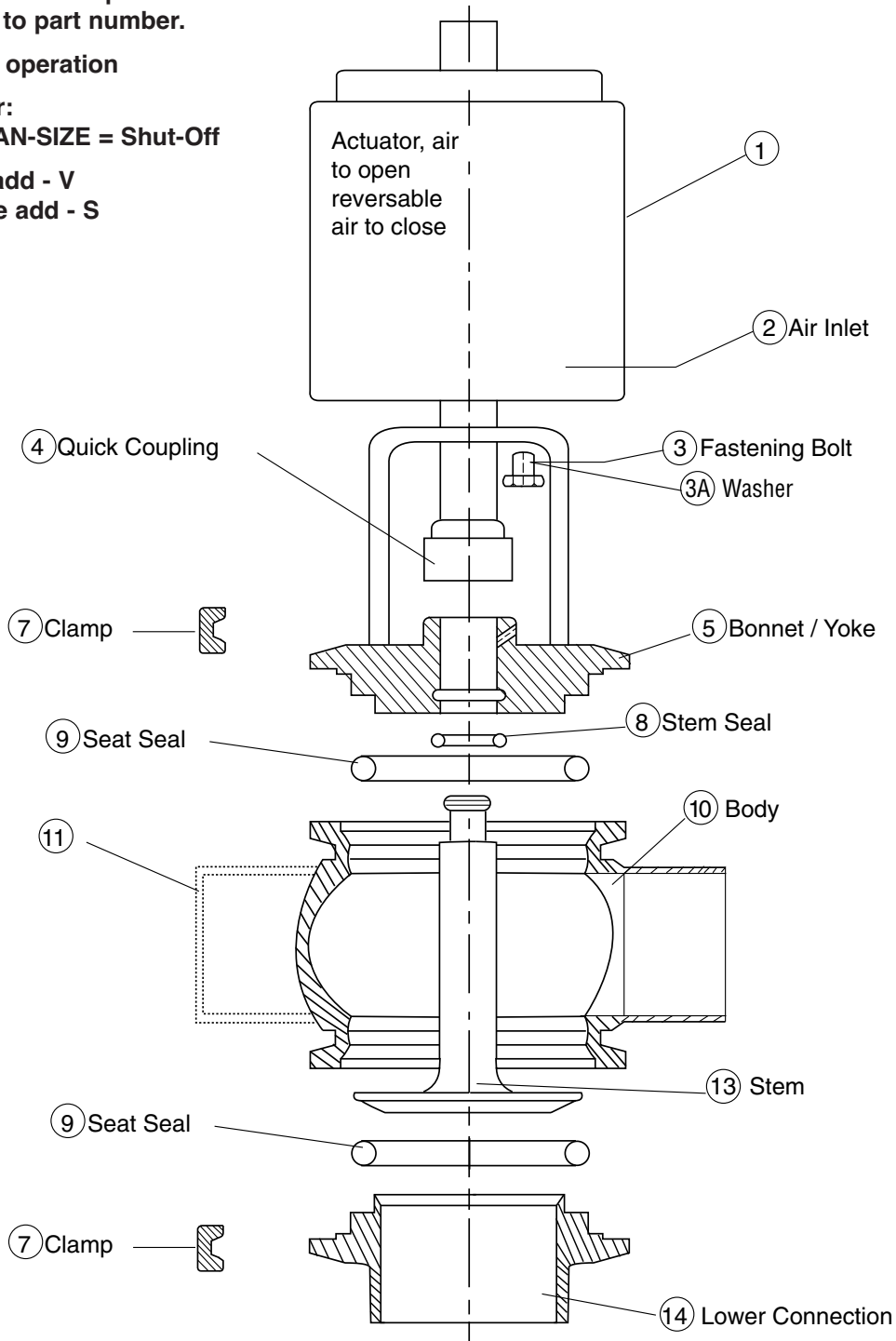

TYPE OF PART NUMBER FOR THE COMPLETE VALVE

EPVAP = Bevel

EPVAI = E-line

EGPVA = Clamp

EPVA = Weld

PVA SHUT OFF VALVE

REPLACEMENT PARTS

Item #	Part Number	Description
1.	PVAP-1-NC-(NO)-1.5 & 2.0	4" Actuator is reversible for normally open or normally closed
	PVAP-1-NC-(NO)-2.5 & 3.0	5" Actuator is reversible for normally open or normally closed
2.	PVAP-2-ALL	Air Inlet
3.	PVAP-3-ALL	Fastening Bolt 2 required for 1 1/2" & 2" Valves
		4 Fastening bolts required for 2 1/2" & 3" Valves
3A.	PVAP-3A-ALL	Washer for fastening bolt
4.	PVAP-4-ALL	Quick Disconnect Coupling
5.	PVAP-5-1.5	Bonnet & Yoke for 1 1/2"
	PVAP-5-2.0	Bonnet & Yoke for 2"
	PVAP-5-2.5	Bonnet & Yoke for 2 1/2"
	PVAP-5-3.0	Bonnet & Yoke for 3"
7.	13MHHMD-3.0	Heavy Duty Clamp 3" (For 1 1/2" & 2" Valves)
	13MHHMD-4.0	Heavy Duty Clamp 4" (For 2 1/2" & 3" Valves)
8.	PVAP-8-1.5-2.0 (S)(V)	EPDM, Silicone, or Viton® Stem O-Ring (For 1 1/2" & 2" Valves)
	PVAP-8-2.5-3.0 (S)(V)	EPDM, Silicone, or Viton® Stem O-Ring (For 2 1/2" & 3" Valves)
9.	PVAP-9-1.5 (S)(V)	EPDM, Silicone, or Viton® Seat Seal for 1 1/2"
	PVAP-9-2.0 (S)(V)	EPDM Silicone, or Viton® Seat Seal for 2"
	PVAP-9-2.5 (S)(V)	EPDM, Silicone, or Viton® Seat Seal for 2 1/2"
	PVAP-9-3.0 (S)(V)	EPDM, Silicone, or Viton® Seat Seal for 3"
		EPDM is Standard. For Viton® add V and Silicone add S to the end of the part number. (2 required for Shut-off / 4 required for Divert)
*10.	PVAP-7-10C-1.5	Tee Body (C=Clamp, W=Butt-Weld, B=Bevel Seat,E=E-Line)
	PVAP-7-10C-2.0	Tee Body (C=Clamp, W=Butt-Weld, B=Bevel Seat,E=E-Line)
	PVAP-7-10C-2.5	Tee Body (C=Clamp, W=Butt-Weld, B=Bevel Seat,E=E-Line)
	PVAP-7-10C-3.0	Tee Body (C=Clamp, W=Butt-Weld, B=Bevel Seat,E=E-Line)
*11.	PVAP-9-11C-1.5	Cross Body (C=Clamp, W=Butt-Weld, B=Bevel Seat,E=E-Line)
	PVAP-9-11C-2.0	Cross Body (C=Clamp, W=Butt-Weld, B=Bevel Seat,E=E-Line)
	PVAP-9-11C-2.5	Cross Body (C=Clamp, W=Butt-Weld, B=Bevel Seat,E=E-Line)
	PVAP-9-11C-3.0	Cross Body (C=Clamp, W=Butt-Weld, B=Bevel Seat,E=E-Line)
12.	PVAP-12-1.5	Seal Base Adapter 1 1/2" (For Divert Valve Only)
	PVAP-12-2.0	Seal Base Adapter 2" (For Divert Valve Only)
	PVAP-12-2.5	Seal Base Adapter 2 1/2" (For Divert Valve Only)
	PVAP-12-3.0	Seal Base Adapter 3" (For Divert Valve Only)
13.	PVAP-7-13-1.5	Stem for 1 1/2" Shut off
	PVAP-7-13-2.0	Stem for 2" Shut off
	PVAP-7-13-2.5	Stem for 2 1/2" Shut off
	PVAP-7-13-3.0	Stem for 3" Shut off
	PVAP-77-13-1.5	Stem for 1 1/2" Divert Valve
	PVAP-77-13-2.0	Stem for 2" Divert Valve
	PVAP-77-13-2.5	Stem for 2 1/2" Divert Valve
	PVAP-77-13-3.0	Stem for 3" Divert Valve
*14.	PVAP-14C-1.5	Lower Connection (C=Clamp, W=Butt-Weld, B=Bevel Seat,E=E-Line)
	PVAP-14C-2.0	Lower Connection (C=Clamp, W=Butt-Weld, B=Bevel Seat,E=E-Line)
	PVAP-14C-2.5	Lower Connection (C=Clamp, W=Butt-Weld, B=Bevel Seat,E=E-Line)
	PVAP-14C-3.0	Lower Connection (C=Clamp, W=Butt-Weld, B=Bevel Seat,E=E-Line)

***TYPE OF CONNECTIONS: C = Clamp W = Butt-Weld B = Bevel Seat Thread E = E-Line Female**

DIVERT VALVE

EGPVA-77-NC(NO)SIZE

*If control head is required add
110V or 24V to part number.

*For Manual operation

Part Number:
EGPVA-77-MAN-SIZE = Divert

*For Viton® add - V

*For Silicone add - S

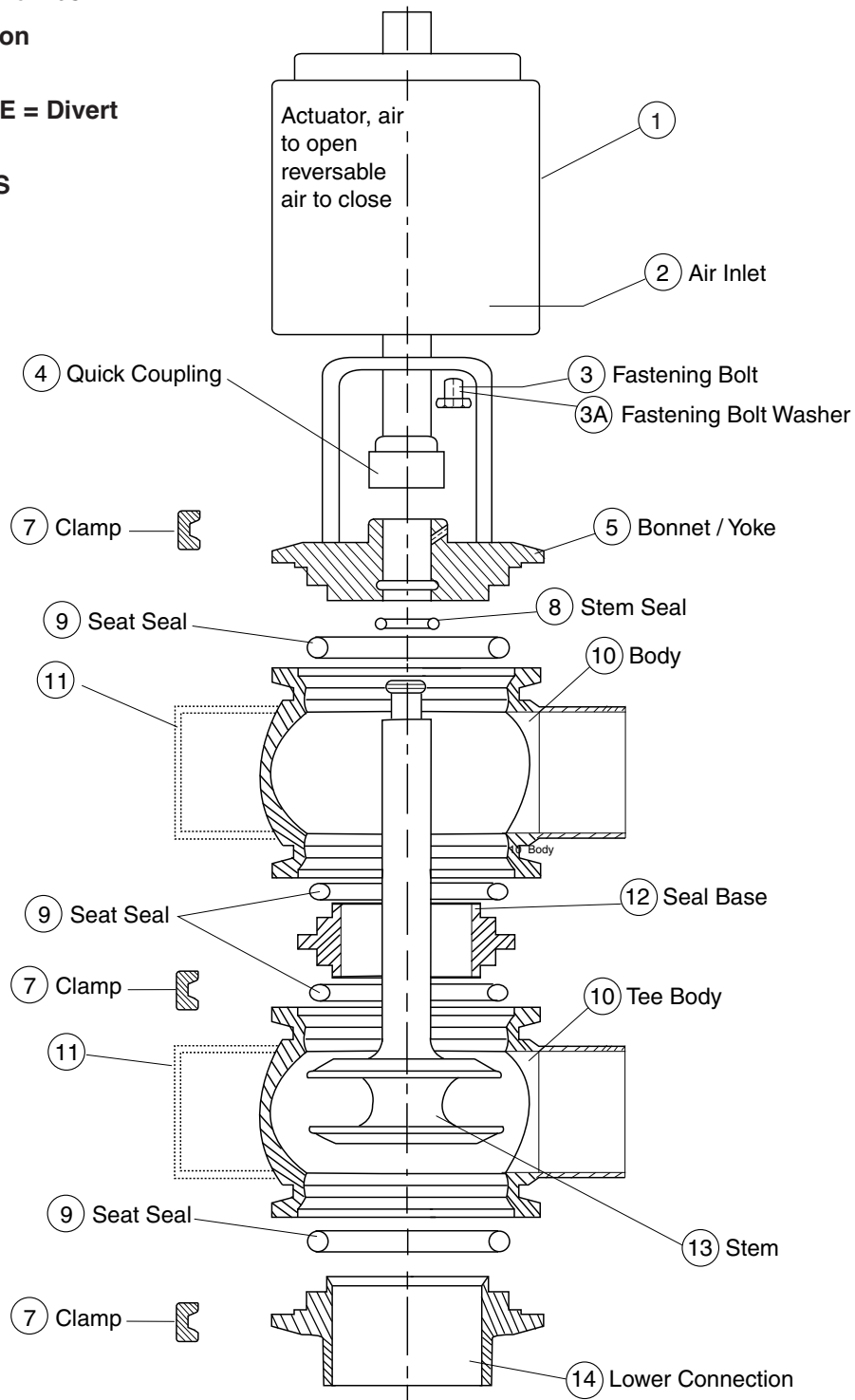

TYPE OF PART NUMBER FOR THE COMPLETE VALVE

EPVAP = Bevel

EPVAI = E-line

EGPVA = Clamp

EPVA = Weld

PVA DIVERT VALVE

REPLACEMENT PARTS

Item #	Part Number	Description
1.	PVAP-1-NC-(NO)-1.5 & 2.0	4" Actuator is reversible for normally open or normally closed
	PVAP-1-NC-(NO)-2.5 & 3.0	5" Actuator is reversible for normally open or normally closed
2.	PVAP-2-ALL	Air Inlet
3.	PVAP-3-ALL	Fastening Bolt 2 required for 1 1/2" & 2" Valves
		4 Fastening bolts required for 2 1/2" & 3" Valves
3A.	PVAP-3A-ALL	Washer for fastening bolt
4.	PVAP-4-ALL	Quick Disconnect Coupling
5.	PVAP-5-1.5	Bonnet & Yoke for 1 1/2"
	PVAP-5-2.0	Bonnet & Yoke for 2"
	PVAP-5-2.5	Bonnet & Yoke for 2 1/2"
	PVAP-5-3.0	Bonnet & Yoke for 3"
7.	13MHHMD-3.0	Heavy Duty Clamp 3" (For 1 1/2" & 2" Valves)
	13MHHMD-4.0	Heavy Duty Clamp 4" (For 2 1/2" & 3" Valves)
8.	PVAP-8-1.5-2.0 (S)(V)	EPDM, Silicone, or Viton® Stem O-Ring (For 1 1/2" & 2" Valves)
	PVAP-8-2.5-3.0 (S)(V)	EPDM, Silicone, or Viton® Stem O-Ring (For 2 1/2" & 3" Valves)
9.	PVAP-9-1.5 (S)(V)	EPDM, Silicone, or Viton® Seat Seal for 1 1/2"
	PVAP-9-2.0 (S)(V)	EPDM, Silicone, or Viton® Seat Seal for 2"
	PVAP-9-2.5 (S)(V)	EPDM, Silicone, or Viton® Seat Seal for 2 1/2"
	PVAP-9-3.0 (S)(V)	EPDM, Silicone, or Viton® Seat Seal for 3"
		EPDM is Standard. For Viton® add V and Silicone add S to the end of the part number. (2 required for Shut-off / 4 required for Divert)
*10.	PVAP-7-10C-1.5	Tee Body (C=Clamp, W=Butt-Weld, B=Bevel Seat,E=E-Line)
	PVAP-7-10C-2.0	Tee Body (C=Clamp, W=Butt-Weld, B=Bevel Seat,E=E-Line)
	PVAP-7-10C-2.5	Tee Body (C=Clamp, W=Butt-Weld, B=Bevel Seat,E=E-Line)
	PVAP-7-10C-3.0	Tee Body (C=Clamp, W=Butt-Weld, B=Bevel Seat,E=E-Line)
*11.	PVAP-9-11C-1.5	Cross Body (C=Clamp, W=Butt-Weld, B=Bevel Seat,E=E-Line)
	PVAP-9-11C-2.0	Cross Body (C=Clamp, W=Butt-Weld, B=Bevel Seat,E=E-Line)
	PVAP-9-11C-2.5	Cross Body (C=Clamp, W=Butt-Weld, B=Bevel Seat,E=E-Line)
	PVAP-9-11C-3.0	Cross Body (C=Clamp, W=Butt-Weld, B=Bevel Seat,E=E-Line)
12.	PVAP-12-1.5	Seal Base Adapter 1 1/2" (For Divert Valve Only)
	PVAP-12-2.0	Seal Base Adapter 2" (For Divert Valve Only)
	PVAP-12-2.5	Seal Base Adapter 2 1/2" (For Divert Valve Only)
	PVAP-12-3.0	Seal Base Adapter 3" (For Divert Valve Only)
13.	PVAP-7-13-1.5	Stem for 1 1/2" Shut off
	PVAP-7-13-2.0	Stem for 2" Shut off
	PVAP-7-13-2.5	Stem for 2 1/2" Shut off
	PVAP-7-13-3.0	Stem for 3" Shut off
	PVAP-77-13-1.5	Stem for 1 1/2" Divert Valve
	PVAP-77-13-2.0	Stem for 2" Divert Valve
	PVAP-77-13-2.5	Stem for 2 1/2" Divert Valve
	PVAP-77-13-3.0	Stem for 3" Divert Valve
*14.	PVAP-14C-1.5	Lower Connection (C=Clamp, W=Butt-Weld, B=Bevel Seat,E=E-Line)
	PVAP-14C-2.0	Lower Connection (C=Clamp, W=Butt-Weld, B=Bevel Seat,E=E-Line)
	PVAP-14C-2.5	Lower Connection (C=Clamp, W=Butt-Weld, B=Bevel Seat,E=E-Line)
	PVAP-14C-3.0	Lower Connection (C=Clamp, W=Butt-Weld, B=Bevel Seat,E=E-Line)

***TYPE OF CONNECTIONS: C = Clamp W = Butt-Weld B = Bevel Seat Thread E = E-Line Female**

PVA AIR ACTUATOR

AIR ACTUATOR CONTROL HEAD

PVAP-ACTUC-110V (24V)
Complete Control Head

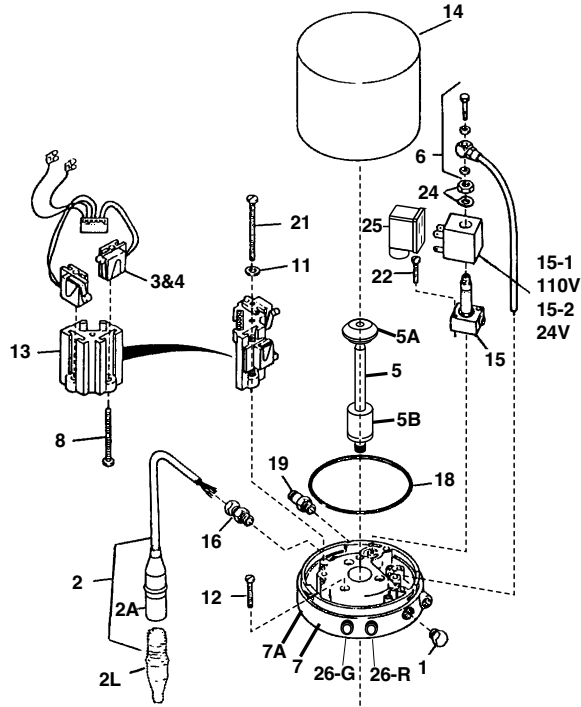

AIR ACTUATOR

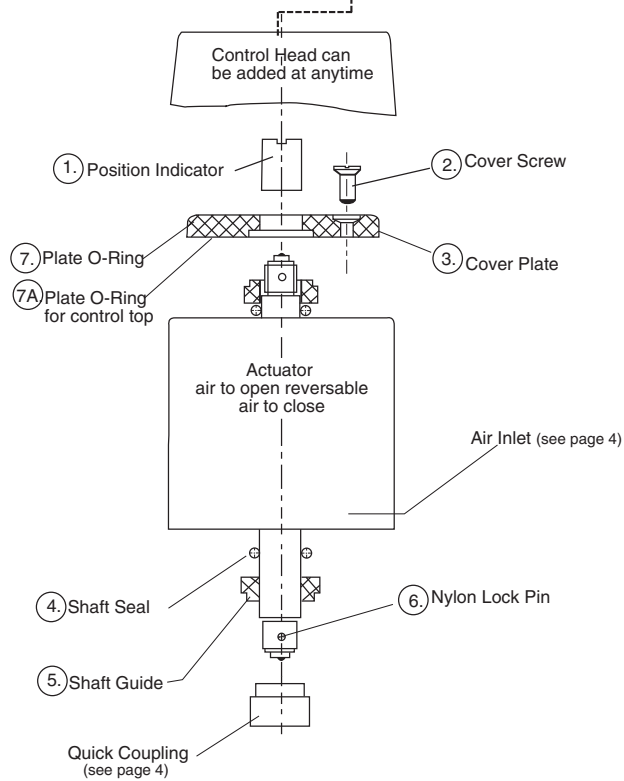

PVA AIR ACTUATOR CONTROL TOP

REPLACEMENT PARTS

Item #	Part Number	Description
1	PVAP-ACTUC-1	Stainless Plug
2	PVAP-ACTUC-2	Electronic Adapter (Complete)
2A	PVAP-ACTUC-2A	Electronic Adapter (Actuator Side)
2L	PVAP-ACTUC-2L	Electronic Adapter (Line Side)
3&4	PVAP-ACTUC-3&4	Micro Switches with Harness and Terminal Strip (Complete)
5	PVAP-ACTUC-5	Micro Switch Actuator Stem
5A	PVAP-ACTUC-5A	Micro Switch Actuator Head
5B	PVAP-ATUC-5B	Stem Guide
6	PVAP-ACTUC-6	Air Vent Tube Assembly
7	PVAP-ACTUC-7	Plastic Molded Base
7A	PVAP-ACTUC-7A	Molded Base Complete With Electronics
8	PVAP-ACTUC-8	Adj. Screws for Micro Switch (2 Required)
10	PVAP-ACTUC-10	Actuator Tube
11	PVAP-ACTUC-11	Washer for Block
12	PVAP-ACTUC-12	Base Screws (3 Required)
13	PVAP-ACTUC-13	Switch Block
14	PVAP-ACTUC-14	Cover
15	PVAP-ACTUC-15	Solenoid Valve
15-1	PVAP-ACTUC-15-1	110V Coil Only
15-2	PVAP-ACTUC-15-2	24V Coil Only
16	PVAP-ACTUC-16	Cable Adapter Fitting
18	PVAP-ACTUC-18	Cover O-Ring
19	PVAP-ACTUC-19	Air Inlet Fitting (Upper)
20	PVAP-ACTUC-20	90° Air Fitting (Upper)
21	PVAP-ACTUC-21	Screw for Block
22	PVAP-ACTUC-22	Screws for Solenoid (2 Required)
24	PVAP-ACTUC-24	Nut and Washer for Coil-Solenoid
25	PVAP-ACTUC-25	Plug Connection to Solenoid
26G	PVAP-ACTUC-26G	Indicating Light (Green)
26R	PVAP-ACTUC-26R	Indicating Light (Red)

PVA AIR ACTUATOR

REPLACEMENT PARTS

Item #	Part Number	Description
1.	PVAP-ACT-1	Position Indicator
2.	PVAP-ACT-2	Cover Screw (2 pcs. required)
3.	PVAP-ACT-3	Cover Plate
	PVAP-ACT-3A	Plate for Control Top (2 O-Rings Required 7 and 7A)
4.	PVAP-ACT-4	Shaft Seal
5.	PVAP-ACT-5	Shaft Guide
6.	PVAP-ACT-6	Nylon Lock Pin
7.	PVAP-ACT-7	Plate O-Ring (For Control Top Only)
7A.	PVAP-ACT-7A	Plate O-Ring (For Control Top Only)

TANK-BOTTOM VALVE

EGPVA-7-TANK-SIZE

Item #	Part Number	Description
1.	PVAP-TANK-1.5	Tank Bottom Plate for 1 1/2"
	PVAP-TANK-2.0	Tank Bottom Plate for 2"
	PVAP-TANK-2.5	Tank Bottom Plate for 2 1/2"
	PVAP-TANK-3.0	Tank Bottom Plate for 3"
2.	PVAP-9-1.5 (S)(V)	Seat Seal, EPDM Standard, Silicone, and Viton® option (3 seals required)
	PVAP-9-2.0 (S)(V)	Seat Seal, EPDM Standard, Silicone, and Viton® option (3 seals required)
	PVAP-9-2.5 (S)(V)	Seat Seal, EPDM Standard, Silicone, and Viton® option (3 seals required)
	PVAP-9-3.0 (S)(V)	Seat Seal, EPDM Standard, Silicone, and Viton® option (3 seals required)
3.	13MHMD-3.0	Clamp for 1 1/2" & 2"
	13MHMD-4.0	Clamp for 2 1/2" & 3"
4.	PVAP-TANK-4-1.5	Stem
	PVAP-TANK-4-2.0	Stem
	PVAP-TANK-4-2.5	Stem
	PVAP-TANK-4-3.0	Stem
5.	PVAP-TANK-5-1.5	Bonnet & Yoke
	PVAP-TANK-5-2.0	Bonnet & Yoke
	PVAP-TANK-5-2.5	Bonnet & Yoke
	PVAP-TANK-5-3.0	Bonnet & Yoke
6.	PVAP-7-10C-1.5	Tee Body (C = Clamp, W = Weld, B = Bevel Seat, E = E-Line)
	PVAP-7-10C-2.0	Tee Body (C = Clamp, W = Weld, B = Bevel Seat, E = E-Line)
	PVAP-7-10C-2.5	Tee Body (C = Clamp, W = Weld, B = Bevel Seat, E = E-Line)
	PVAP-7-10C-3.0	Tee Body (C = Clamp, W = Weld, B = Bevel Seat, E = E-Line)
7.	PVAP-12-1.5	Seal Base Adapter
	PVAP-12-2.0	Seal Base Adapter
	PVAP-12-2.5	Seal Base Adapter
	PVAP-12-3.0	Seal Base Adapter
8.	PVAP-8-1.5-2.0 (V)	Stem O-Ring EPDM Standard, Viton® option
	PVAP-8-2.5-3.0 (V)	Stem O-Ring EPDM Standard, Viton® option
9.	PVAP-1-NC(NO)-1.5 & 2.0	4" Actuator Regulates 1 1/2" - 3" Valves
10.	PVAP-MANUAL-ALL	Manual Handle is Optional (Fits All Sizes)

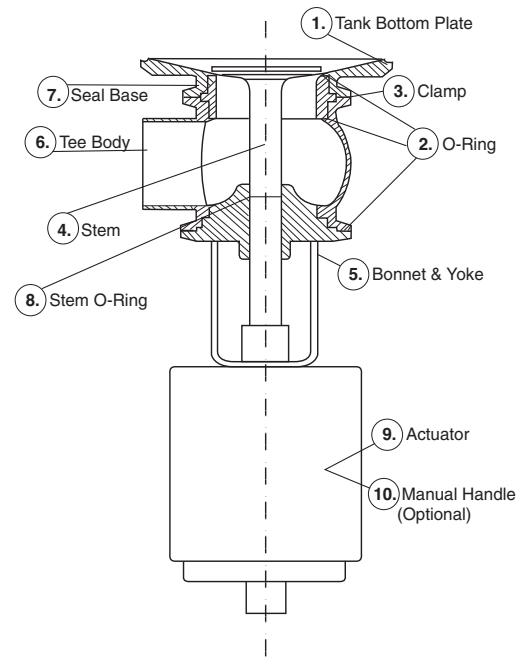

PVA MANUAL AND ADDITIONAL ACTUATORS

MANUAL ACTUATOR, ACTUATOR, & ACTUATOR WITH CONTROL HEAD

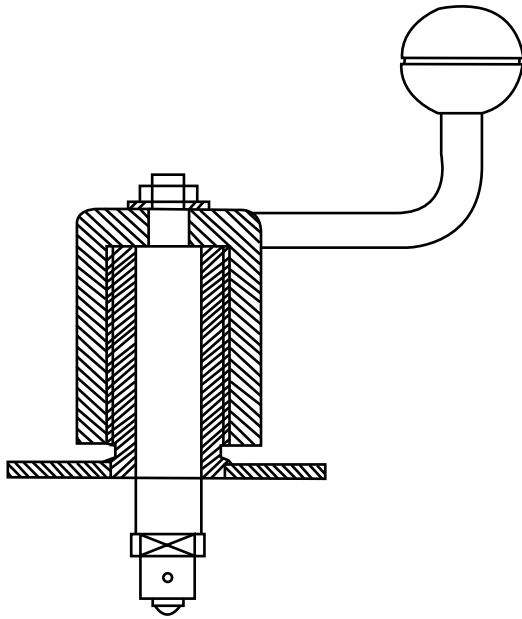

1

Manual Actuator

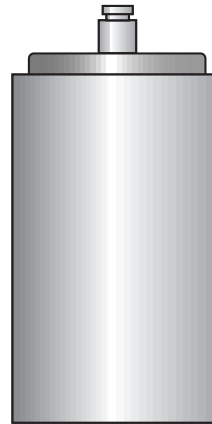

2

Actuator

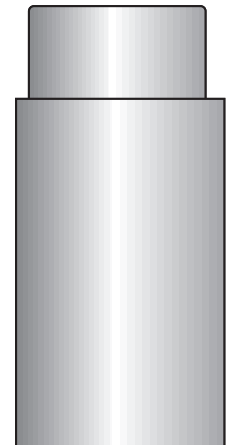

3

Actuator
with control head

PVA MANUAL AND ADDITIONAL ACTUATORS

REPLACEMENT PARTS

Item #	Part Number	Description
1.	PVAP-MANUAL-ALL	Shut off, Divert and Tank Valve Handle Complete (Fits All Sizes)
2.	PVAP-1-NC-1.5 & 2.0	Pneumatic Actuator (For 1 1/2" & 2" Valves)
	PVAP-1-NC-2.5 & 3.0	Pneumatic Actuator (For 2 1/2" & 3" Valves)
3.	PVAP-1-NC-1.5 & 2.0-110V (24V)	Pneumatic Actuator with Control Head (For 1 1/2" & 2" Valves)
	PVAP-1-NC-2.5 & 3.0-110V (24V)	Pneumatic Actuator with Control Head (For 2 1/2" & 3" Valves)

PVA VALVES DIAGRAMS

PRESSURE DROP / CAPACITY DIAGRAMS

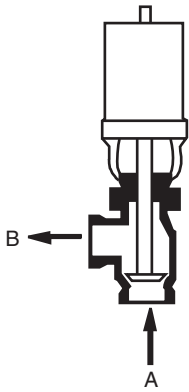

Shut - off Valve

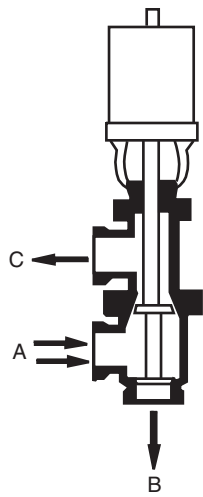
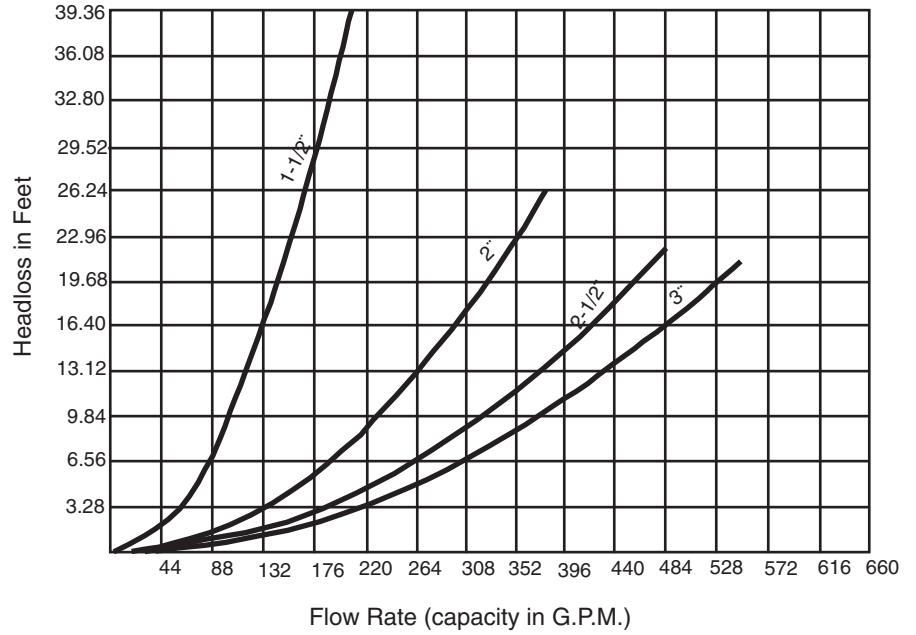

Divert Valve

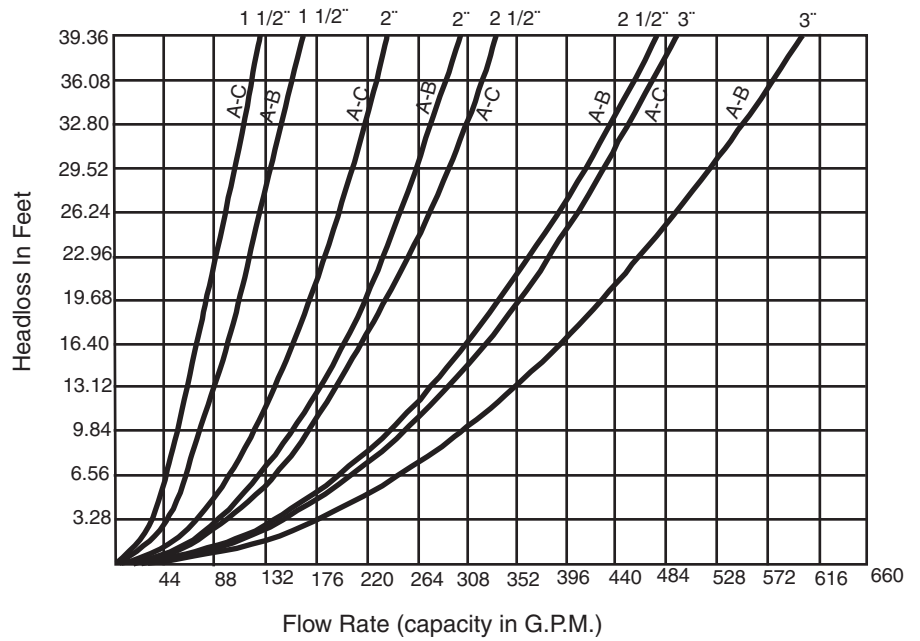

COMPRESSION VALVE

INFORMATION

- One piece stem with O-Ring construction (easy seal replacement and positive shut-off)
- Viton O-Ring standard (others available upon request)
- TRI-Clamp connections are standard
- Full Polished ID and OD
- All metal contact surfaces of T316L Stainless Steel
- Sizes range from 1.0" through 3.0"



PARTS BREAKDOWN

1. Body
2. Stem
- 2B. O-Ring Stem Seal
- 2C O-Ring Stem Seat
- 2E Cotter Pin
3. Bonnet
4. Handle

EG40V(SIZE)=Viton Clamp Gasket

13MHMD(SIZE)-H=Clamp

Max. Product Pressure 150 PSI

Max Temperature 200°F

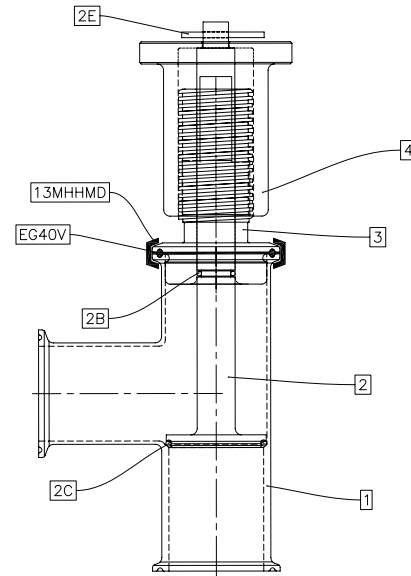

Part Number Sequence When Ordering Complete Valve - EG60C-7-R-SIZE

E	G	60	C	7	R	SIZE
Polished	Clamped	Manual	Compression	Tee-Style	Rubber	1.0

Overall Length				
Valve Size	A	B		Approx WT LBS
		MIN	MAX	
1.0	5.375	5.750	6.375	2.25
1.5	6.375	8.000	9.625	6.3
2.0	7.875	8.750	11.000	9.9
2.5	9.250	10.375	13.500	18
3.0	10.375	12.500	16.375	26.1



vnestainless.com



VNE Corporation

P.O. Box 1698 • 1149 Barberry Drive • Janesville, WI 53547
608-756-4930 • 1-800-356-1111 • Fax: 608-756-3643